

150mm Centre Single Glazed

TECHNICAL MANUAL



SLS - 2000Pa
ULS - 2200Pa



Air - 0.49L
Water - 800Pa



Acoustic - Rw 38
Estimate 10.5mm



Fire Rating Tested
- DTS

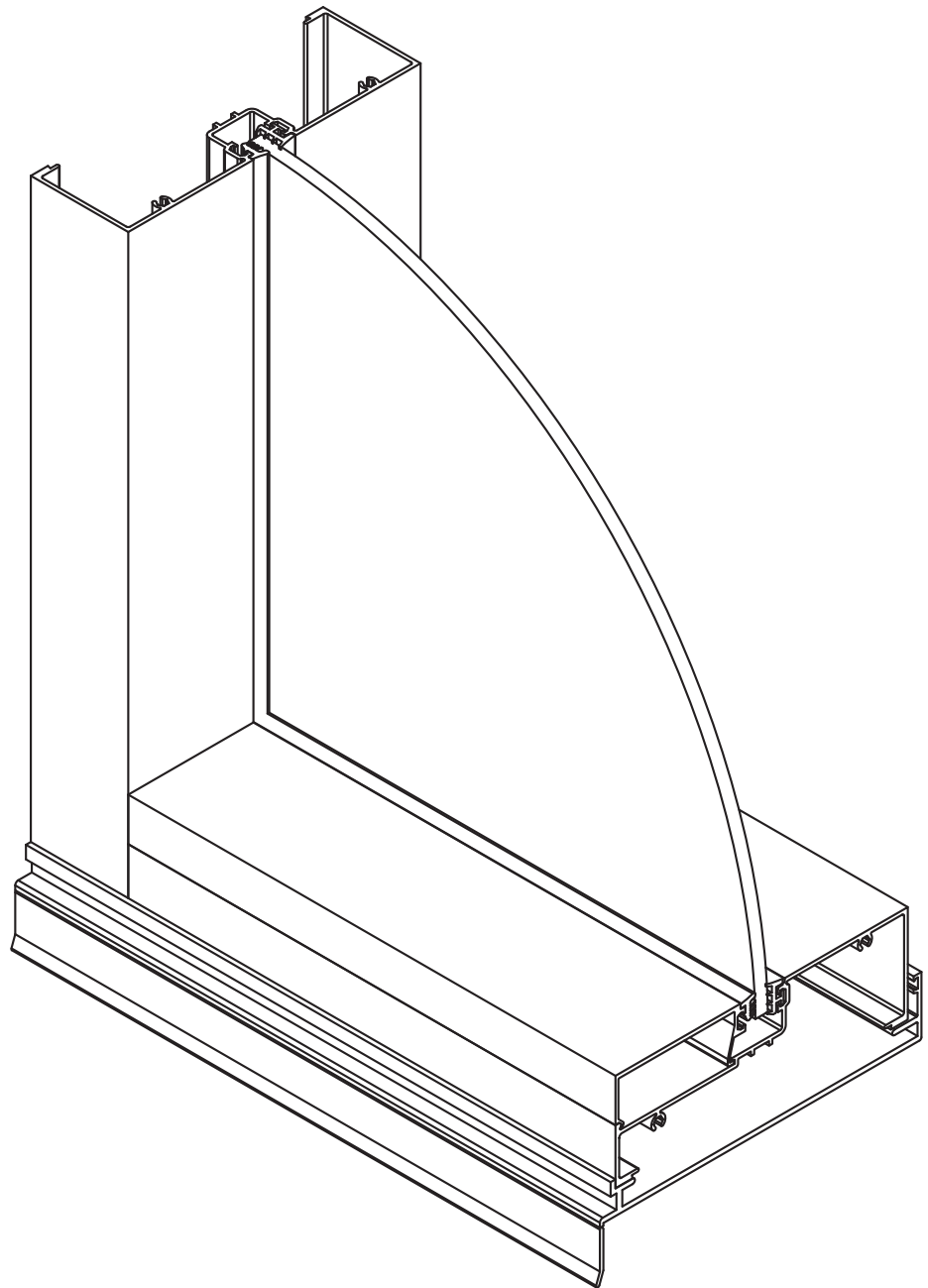

53mm
76mm
100mm
150mm
165mm
200mm
250mm

JUN 2026 | VERSION11



U-Value
4.1 - 6.1



Subsill
Draining



Transom
Draining



Disclaimer

Darley Aluminium strives to ensure the technical details contained in this manual are complete and correct. Occasionally, some errors or outdated information may require rectification - Darley Aluminium takes no responsibility for any loss or damage as a result of these errors. If you are unsure of any information provided within this manual, please contact your nearest Darley Aluminium office.

Engineering, manufacture and installation of frames must meet requirements of AS2047 (Windows in Buildings).

Glazing selected must meet requirements of AS 1288 (Glass in Buildings).

Size limitations are governed by design intent, glass selection, and local wind load requirements as per AS/NZS 1170.2 (Wind Actions) or AS 4055 (Wind Loads for Housing). An Engineer should be consulted to ensure selected framing and installation meets the requirements as set out by the relevant Australian Standards.

Any reference to an Australian Standard within this manual is based on the interpretations of Darley Aluminium. Code Compliance responsibility remains with the user of this manual. Misuse or misinterpretation of the information in this manual or of the Australian Standards remains the responsibility of the user of this manual.

Engineering, manufacture and installation must meet requirements of AS 2047, AS3959, WERS and Acoustic requirements. Glazing selected must meet requirements of AS 1288. Size limitations are governed by design intent, glass selection, and local wind load requirements as per AS/NZS 1170.2 or AS 4055.

N.B.- For frames, designs, and configurations outside the tested scope, an engineer or suitably qualified person should be consulted.

Copyright

This technical manual and the information within remains the property of Darley Aluminium. The manual must not be reproduced, copied or loaned without prior agreements with Darley Aluminium.

Contents

Introduction	5
Welcome	5
Overview.....	5
Design Features.....	5
Performance Summary	5
System Requirements.....	5
1:1 Section Profiles	6
Hardware	13
Performance	16
Test Results	16
Acoustic Test Report Estimate	18
BAL Compliance	19
Glazing	24
Glass & Rubber Combinations.....	24
Fabrication	25
Configuration	25
Energy Rating Definitions	26
Cross Sections	30
Head & Sill Option	31
Head & Sill Option	32
Transom Option	33
Jamb Option: Sub Jamb	34
Mulion.....	36
Machining	45
Cutting Formula.....	45
Component Assembly	46
Sub-Framing Details	49
Tooling	57
KlassicView / CityView / ClimateGuard	58
Tooling Operation Manual	58
Appendix	60
Maintenance & Warranty	60
Release Notes	62

Welcome

Overview

Darley's 150 x 50 mm Centre Single Glazed Framing System is the ideal choice for modern architectural requirements, meeting current design trends as well as performance specifications. The system is ideally suited to shopping centres, offices, show rooms and commercial buildings. It is also widely used in high end residential developments and apartments. Framing options include hinged or sliding door combinations and can be incorporated with a variety of awnings / casements and hinge doors. All Darley framing systems are available in powder coated and anodised finishes. (Refer to Darley Aluminium Product Catalogue for further information.)

Design Features

- Accepts glass thickness from 6mm to 12.38mm.
- Compatible with other Darley Aluminium Commercial and Residential Systems
- Accepts a variety of window options
- Accepts a variety of hinged and sliding door systems
- Range of sub head and sub sill options
- Tested and Approved by an independent NATA accredited laboratory

Performance Summary

100 x 50mm Centre Single Glazed Framing							
MaxTested Panel Size	SLS	ULS	Water	Air Infiltration	Acoustic	BAL	Glass
3000 x 1483mm	2000Pa	2200Pa	800Pa	+ 0.35L/s.m ² - 0.49L/s.m ²	Est. 38Rw*	DTS	6-12.38mm

*Estimated based on 150 x 50mm centre glazed frame

See Performance Section for more detail.

Size limitations are governed by design intent, glass selection and local wind load and deflection requirements. For further technical assistance and fabricator selection contact Darley Aluminium. An Engineer should be consulted to ensure selected framing meets the requirements as set out in the relevant Australian Standards

System Requirements

- Engineering, manufacture and installation of frames must meet requirements of:
 - AS2047-2014 (Windows and External Glazed Doors in Buildings)
- Glazing selected must meet requirements of AS1288:2021 (Glass in Buildings - Selection and Installation)

Section Profiles

Scale 1:1

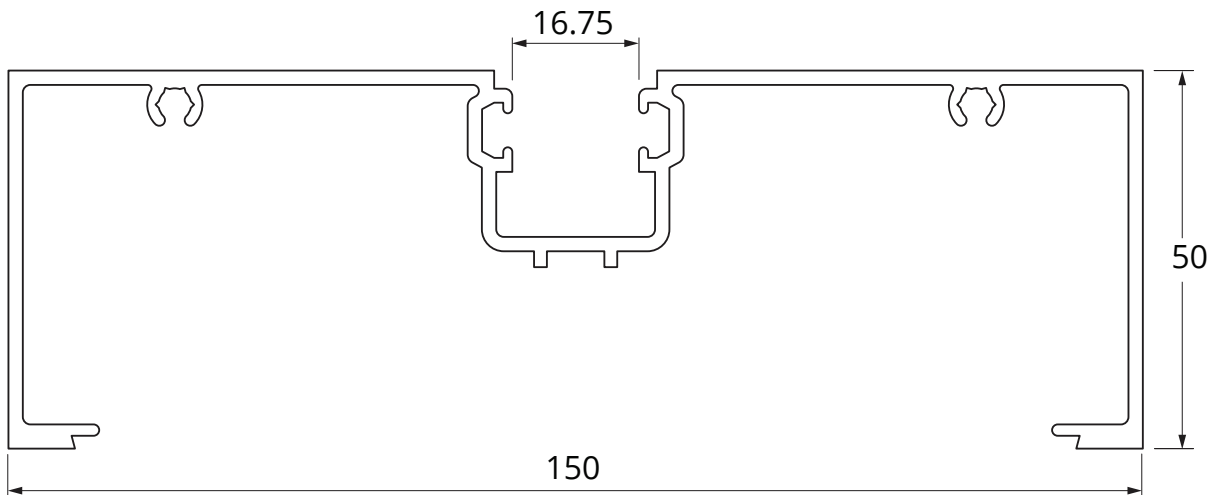
**CSG601**

MainFrame

$$I_{xx} = 117.112 \times 10^3 \text{ mm}^4$$

$$I_{yy} = 1908.611 \times 10^3 \text{ mm}^4$$

A.P. = 701 mm

P.P. = 246 mm

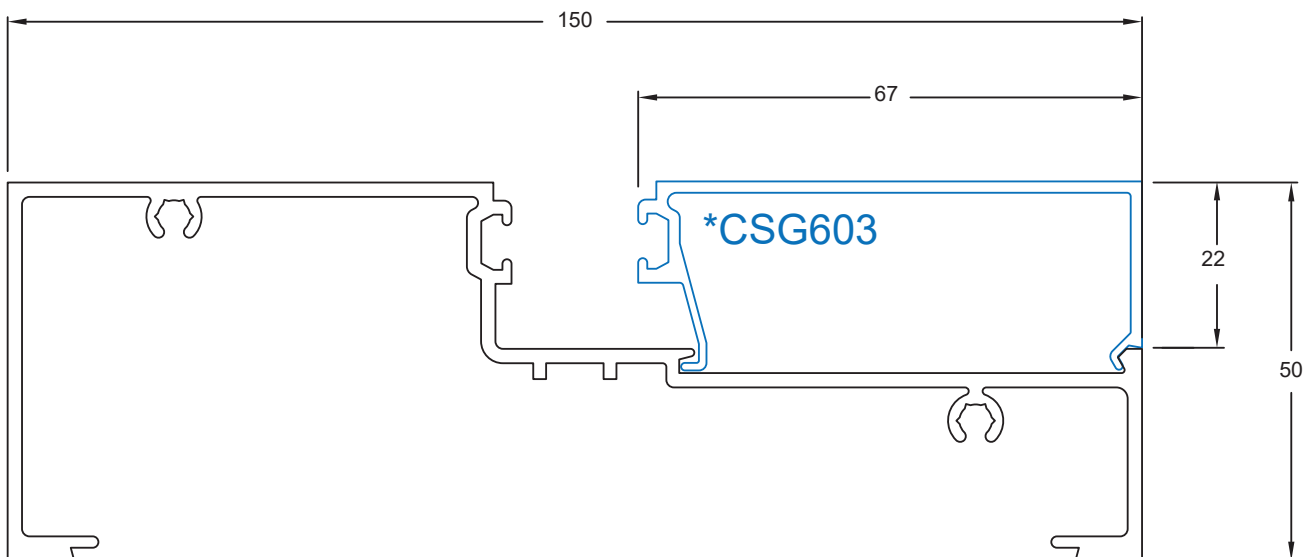
**CSG602**

Sill/Transom

$$I_{xx} = 141.779 \times 10^3 \text{ mm}^4$$

$$I_{yy} = 1683.978 \times 10^3 \text{ mm}^4$$

A.P. = 618 mm

P.P. = 160 mm

CSG603

Bead

$$I_{xx} = 10.690 \times 10^3 \text{ mm}^4$$

$$I_{yy} = 126.364 \times 10^3 \text{ mm}^4$$

A.P. = 248 mm

P.P. = 100 mm

Mainframe Profiles

Scale 1:1

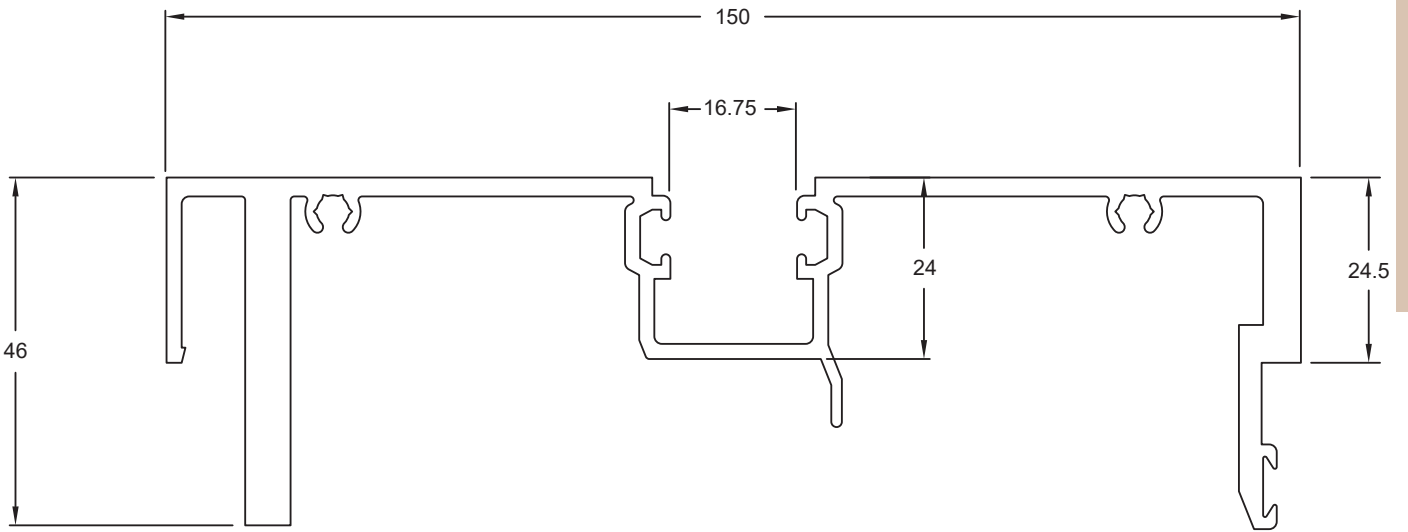

CSG633

Heavy Duty
Self Mating Mullion

$$I_{xx} = 178.332 \times 10^3 \text{ mm}^4$$

$$I_{yy} = 3006.514 \times 10^3 \text{ mm}^4$$

A.P. = 692 mm
P.P. = 215 mm

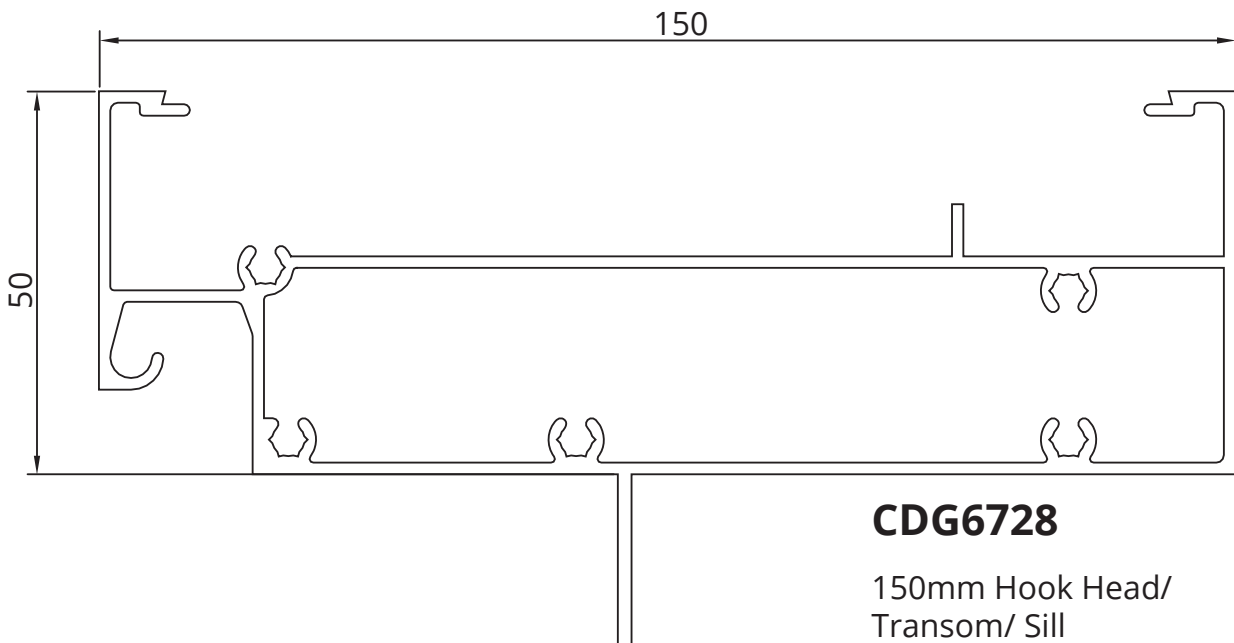

CDG6728

150mm Hook Head/
Transom/ Sill

$$I_{xx} = 197.2 \times 10^3 \text{ mm}^4$$

$$I_{yy} = 1936.9 \times 10^3 \text{ mm}^4$$

A.P. = 606 mm
P.P. = 295 mm

Mainframe Profiles

Scale 1:1

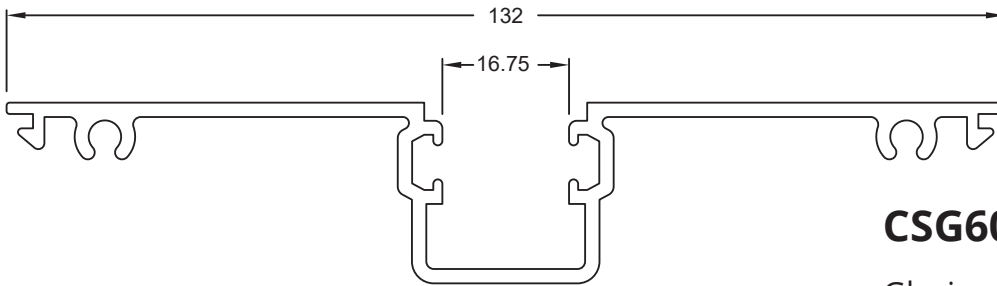
**CSG604**

Glazing Adaptor

$$I_{xx} = 24.187 \times 10^3 \text{ mm}^4$$

$$I_{yy} = 575.184 \times 10^3 \text{ mm}^4$$

A.P. = 442 mm

P.P. = 111 mm

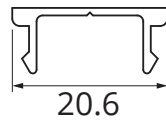
**FGS406**

Pocket Filler

$$I_{xx} = 0.3 \times 10^3 \text{ mm}^4$$

$$I_{yy} = 2.3 \times 10^3 \text{ mm}^4$$

A.P. = 74 mm

P.P. = - mm

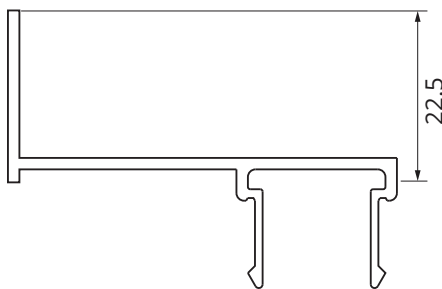
**CSG620**

35mm Awning Stop

$$I_{xx} = 6.1 \times 10^3 \text{ mm}^4$$

$$I_{yy} = 16.1 \times 10^3 \text{ mm}^4$$

A.P. = 224 mm

P.P. = 100 mm

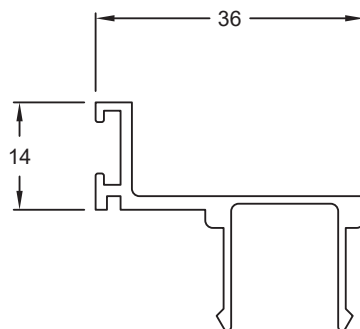
**CSG606**

45mm or 40mm Door Stop

$$I_{xx} = 5.644 \times 10^3 \text{ mm}^4$$

$$I_{yy} = 17.074 \times 10^3 \text{ mm}^4$$

A.P. = 179 mm

P.P. = 100 mm

Subframing Profiles

Scale 1:1

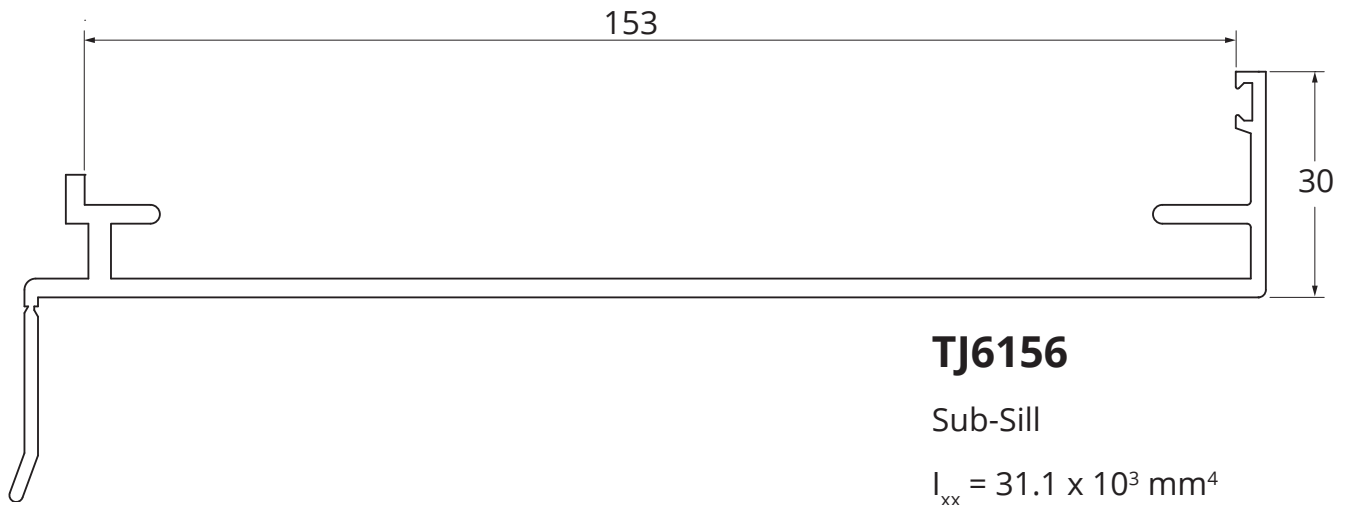

TJ6156

Sub-Sill

$$I_{xx} = 31.1 \times 10^3 \text{ mm}^4$$

$$I_{yy} = 2110.1 \times 10^3 \text{ mm}^4$$

A.P. = 524 mm

P.P. = 100 mm

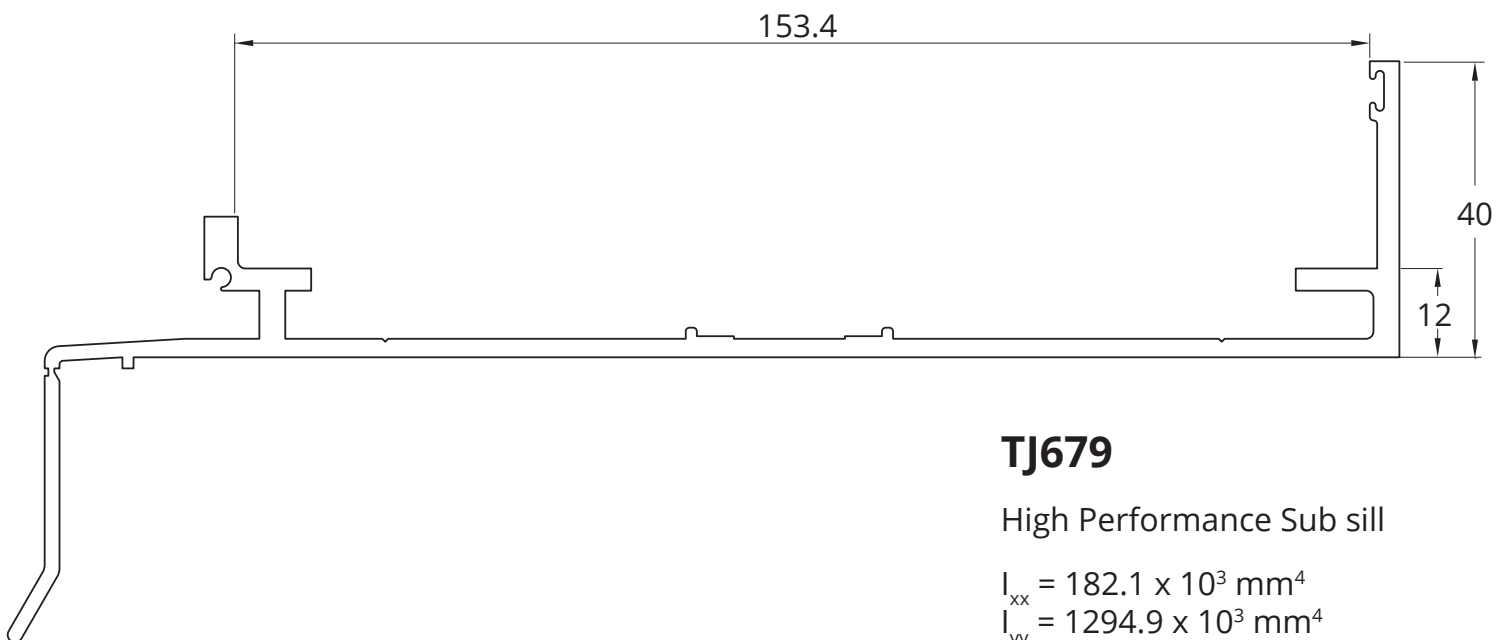

TJ679

High Performance Sub sill

$$I_{xx} = 182.1 \times 10^3 \text{ mm}^4$$

$$I_{yy} = 1294.9 \times 10^3 \text{ mm}^4$$

A.P. = 529 mm

P.P. = 274 mm

Subframing Profiles

Scale 1:1

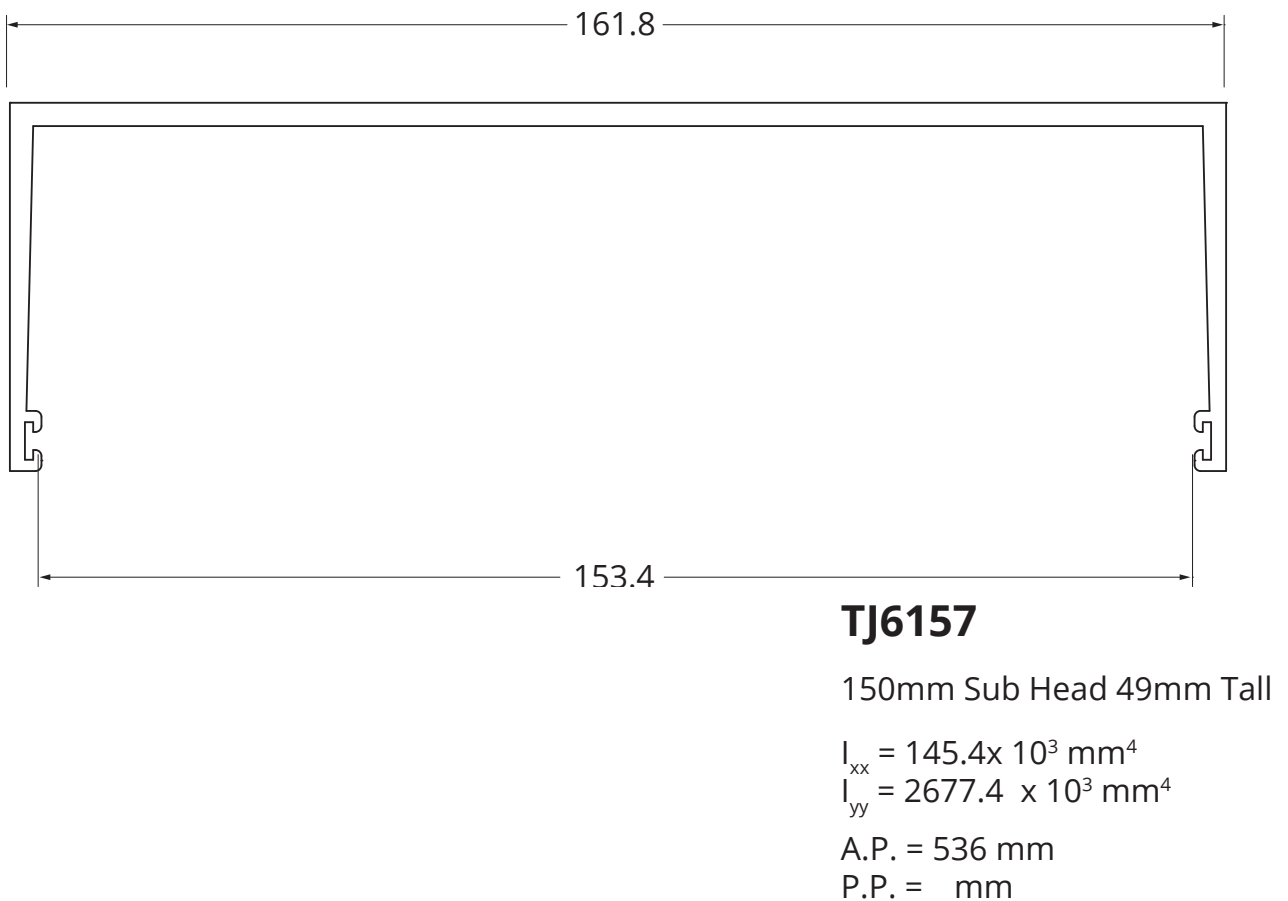
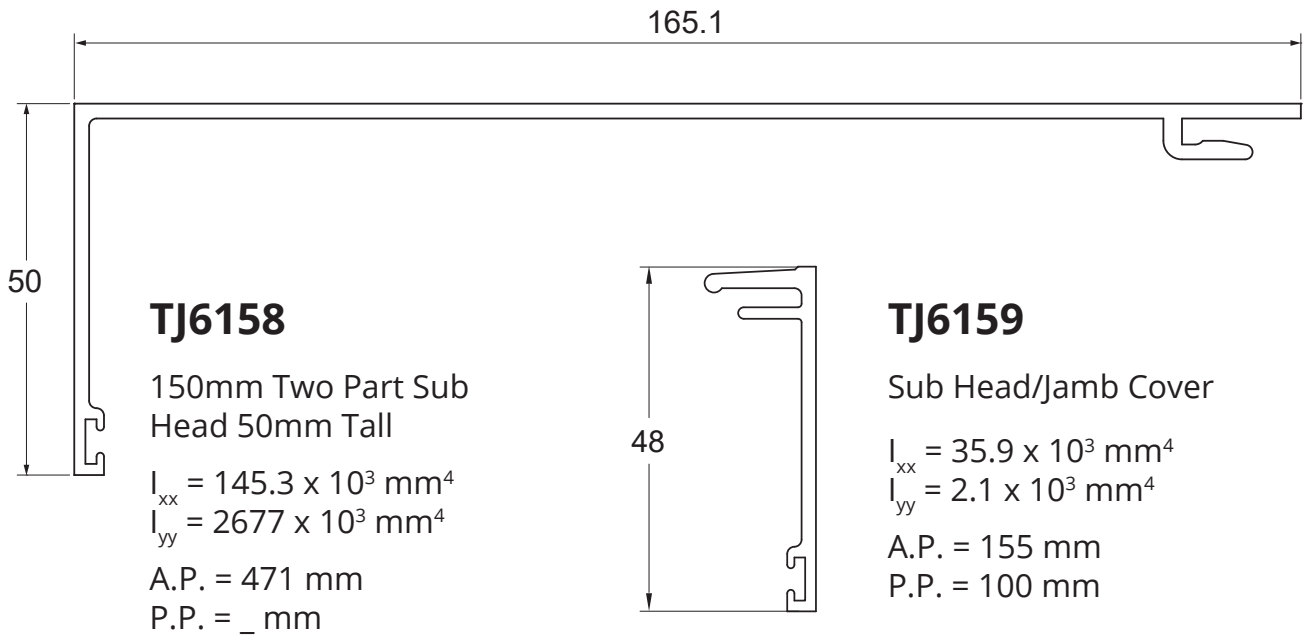

Subframing Profiles

Scale 1:1

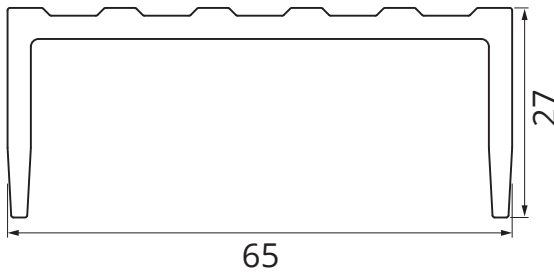

TJ468

Drainage Gate (Fits TJ400 & TJ600)

$$I_{xx} = 21.32 \times 10^3 \text{ mm}^4$$

$$I_{yy} = 214.23 \times 10^3 \text{ mm}^4$$

A.P. = 232 mm

P.P. = 150 mm

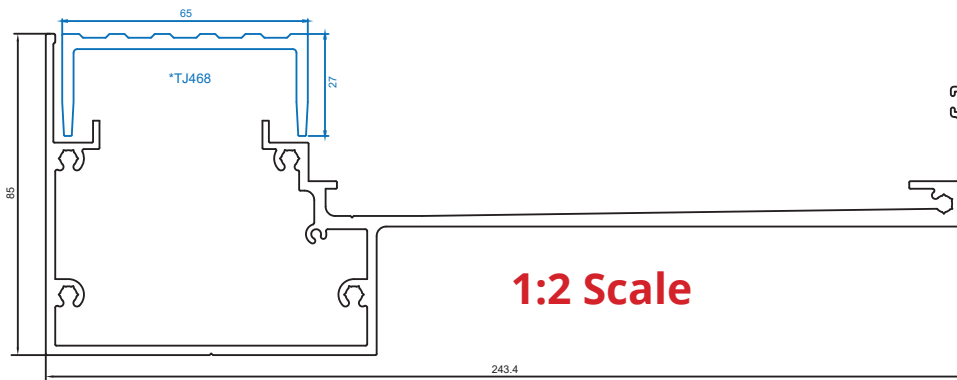

TJ650

150mm Sump Sill

A.P. = 1054 mm

P.P. = 409 mm

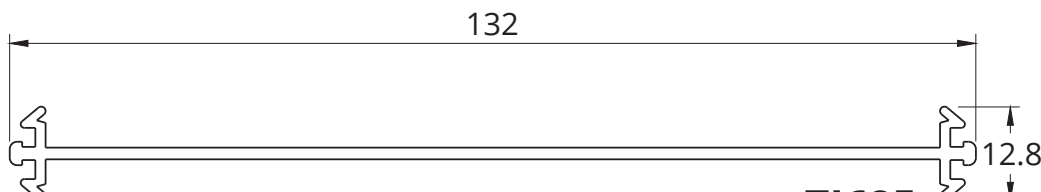

TJ685

Back-to-Back Adaptor (For 150 & 152.4mm Frame)

$$I_{xx} = 0.670 \times 10^3 \text{ mm}^4$$

$$I_{yy} = 482.034 \times 10^3 \text{ mm}^4$$

A.P. = 330 mm

P.P. = - mm

Subframe Profiles

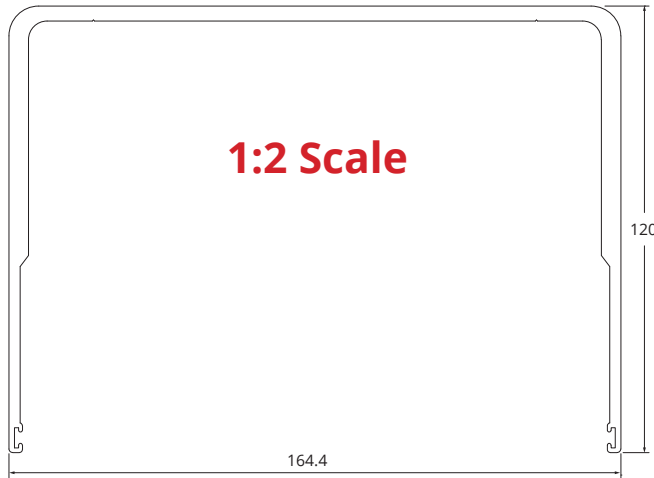
**TJ6155**

150mm Sub Head 120mm Deep

$$I_{xx} = 2019.12 \times 10^3 \text{ mm}^4$$

$$I_{yy} = 7606.43 \times 10^3 \text{ mm}^4$$

A.P. = 804 mm

P.P. = 246 mm

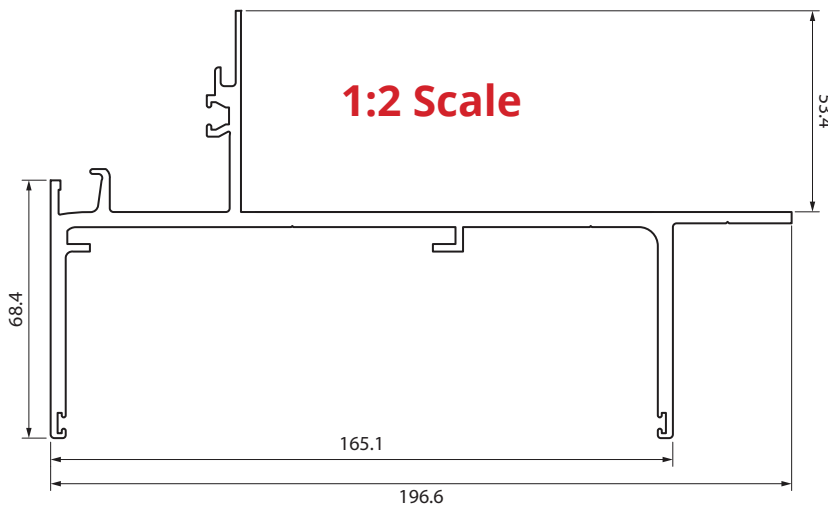
**DGF6563**

150mm DG Spandrel
Sub Head 60mm Tall

A.P. = 860 mm

P.P. = 208 mm

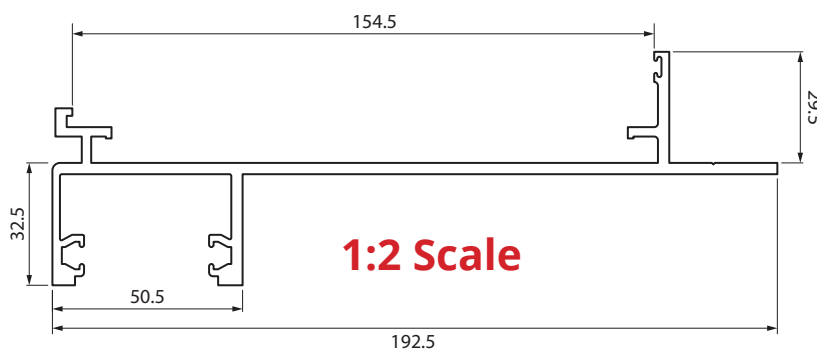





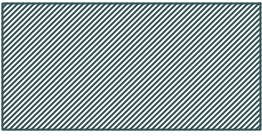

**DGF6562**

150mm Front DG
Spandrel Subsill









A.P. = 704 mm

P.P. = 145 mm



Small Parts

	Code	Description	U.O.M	BOX QTY.
	1475	Foam Seal - 1120 Pieces Roll Suits 150mm Front Glazed Single	Roll	1
	1493	Foam Plug Suits: Centre Single Glazed Framing (20 Per Sheet)	Roll	1
	1494	Foam Plug Suits: Front Single Glazed Framing (16 Per Sheet)	Roll	1
	1610-M100	6mm Door Stop - 100m	Roll	1
	1611	Weatherstrip 90-900 Black - 150m Roll	Roll	1
	1614	Door Stop Rubber - Large 200m	Roll	1
	1615	Glazing Wedge PVC - 200m Roll	Roll	1
	1620	Glazing Wedge PVC - 200m Roll	Roll	1
	1625	Glazing Wedge PVC for 8.38mm Glass - 250m Roll	Roll	1
	1630	Glazing Wedge PVC - 200m Roll	Roll	1
	1645	Glazing Wedge Captive Co-Extruded Santoprene - 100m Roll	Roll	N/A

Small Parts

	Code	Description	U.O.M	BOX QTY.
	1646	Glazing Wedge Captive Co-Extruded Santoprene - 100m Roll	Roll	N/A
	1647	Glazing Wedge Captive Co-Extruded Santoprene - 100m Roll	Roll	N/A
	1660	V Seal (Mullion Rubber) - 500m Roll	Roll	1
	1900-M	Frame Packers - 1.5mm X 90mm - Blue 100/Bag	Bag	N/A
	1901-M	Frame Packers - 3mm X 90mm - Green 100/Bag	Bag	N/A
	1902-M	Frame Packers - 5mm X 90mm - Ochre 100/Bag	Bag	N/A
	1903-M	Frame Packers - 10mm X 90mm - Black 100/Bag	Bag	N/A
	1906	Aluminium Frame Packers 1mm - 100/Bag	Bag	N/A
	1907	Aluminium Frame Packers 2mm - 100/Bag	Bag	N/A
	1908	Aluminium Frame Packers 5mm - 100/Bag	Bag	N/A
	1909	Aluminium Frame Packers 10mm - 100/Bag	Bag	N/A

Small Parts

	Code	Description	U.O.M	BOX QTY.
	1912	Setting Blocks 10mm Thick - Bag of 500	Bag	N/A
	1977	Setting Blocks 5mm X 25mm - 3m Self Adhesive - Bag of 200	Bag	N/A
	1978	Setting Blocks 10mm X 25mm - 3m Self Adhesive - Bag of 200	Bag	N/A
	1979	Setting Blocks 3mm X 10mm X 25mm - 3m Double Sided Tape - Bag of 200	Bag	N/A
	1608	Co-Expansion Seal - 2.7m	Roll	N/A
	1960	Lanotec General Purpose Liquid Lanolin 400g	Tube	12
	1961	Lanotec "Citra Force" Cleaner Degreaser 400g	Tube	12
	BDX-CV-CS-G/H/AW	CSG Frame / Hinged / Hook Awning Hydraulic Tool		

Test Results

Performance

PERFORMANCE							
System	Test Size	Panel Size	Ser	Water	Ult	Report	Glass
150mm Centre (CSG)	3250 x 2400	3130 x 1200	1200	600	3500	AZT0486.24	8mm tough

ACOUSTIC PERFORMANCE				
System	Rw	C : C _{TR}	Report	Glass
CityView 150 CSG	38	-1 : -2	Estimate based on TL769-08.1	12.5 Hush Lam

BAL FIRE RATING			
System	BAL	Report	Glass
CityView 150 CSG	BAL-40	DTS	6mm Toughened

TESTED BY NEUTRAL THIRD PARTIES



See Performance Section for more detail. Taller maximums may be achievable via strength charts. Size limitations are governed by design intent, glass selection and local wind load and deflection requirements.

For further technical assistance and fabricator selection contact Darley Aluminium. An Engineer should be consulted to ensure selected framing meets the requirements as set out in the relevant Australian Standards

Structural Test Report: 150mm Centre (CSG) - Heavy Duty

The following data was obtained from the results of the tests on the 150mm Centre (CSG) only as performed in the Azuma Testing Laboratory (NATA Accredited).

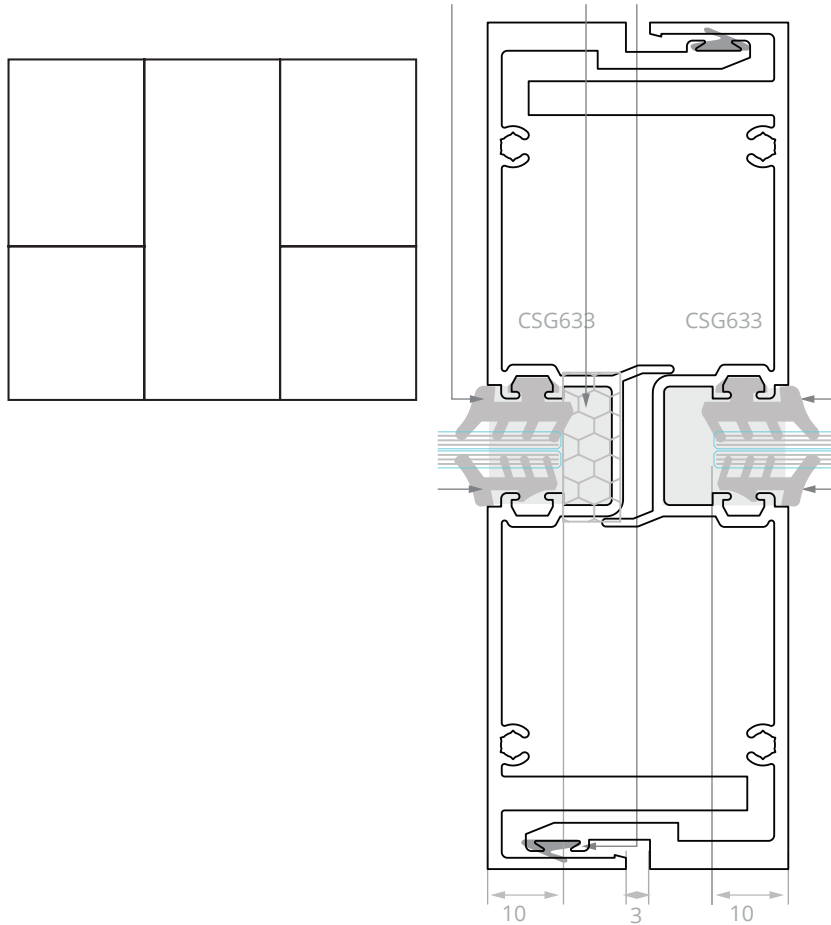

Performance

Test & Date	AZT0486.24, 13/11/2024
Test Size/Panel Size	3062mm H x 4558mm W, 3000mm H x 1483mm W
Mullion/Subsill	CSG633 x2, TJ6156
Serviceability Load	+/- 2000 Pa
Air Infiltration	Low
Water Penetration	800 Pa
Ultimate Strength	+/- 2200 Pa

Acoustic Test Report Estimate

LABORATORY TEST ESTIMATE: CityView 150mm Centre Style Glazed

Tested Rw value of 38 based on testing of 100mm Centre Glazed; see results below

Test Report No. : TL769-08-1	
Test Date	16/06/2023
Glass Type	12mm Hush
Acoustic Rating Rw(C;Ctr)	38 (-1;-2)dB

Measurement Details & Results²

Frequency (Hz)	Specimen R Value (dB)		95 % Conf δ (dB)
	1/3 Octave	Whole Octave	
100	28.7		1.7
125	27.5	28.8	2.4
160	30.6		1.4
200	32.5		1.4
250	32.4	32.9	1.6
315	34.1		1.0
400	34.5		0.8
500	35.1	34.8	0.5
630	35.0		0.3
800	34.5		0.3
1000	38.6	37.0	0.2
1250	40.0		0.2
1600	40.1		0.2
2000	40.1	40.2	0.2
2500	40.3		0.1
3150	40.7		0.2
4000	42.3	42.1	0.3
5000	43.7		0.5

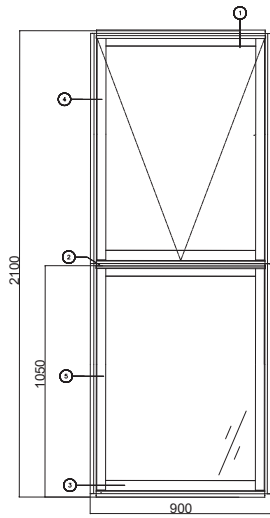

Acoustic

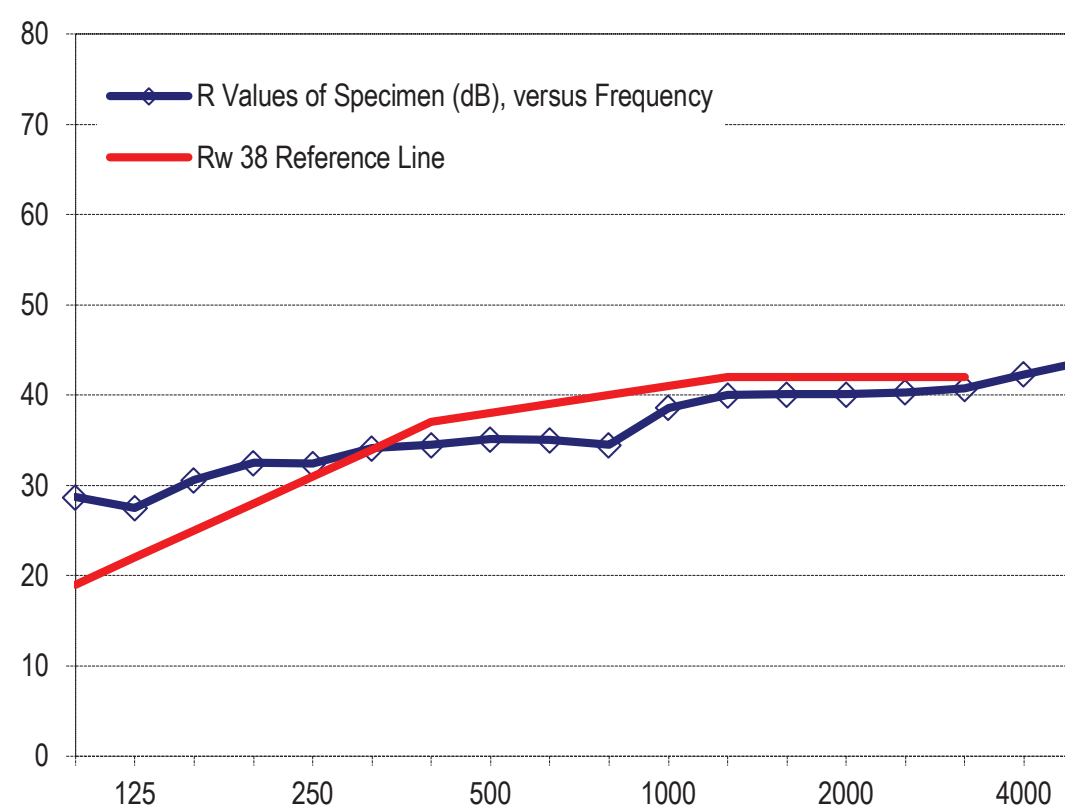

BAL Compliance

Bushfire attack levels

Similar system tested to AS1530.8.1 2018 - BAL 40
 Test covers BAL requirements below BAL-40.
 Alternatively refer to DTS criteria below for alternative compliance method

Test Standard: Clauses 14 and 16 of AS 1530.8.1:2018
Test Sponsor: Darley Aluminium Trading Pty Ltd
Product: Darley CityView Combination Window System
Bushfire Attack Level (BAL) Exposure: 40 kW/m²
Crib Class: AA
Job Number: FRT210417
Test Date: 10 March 2022 **Revision:** R1.0

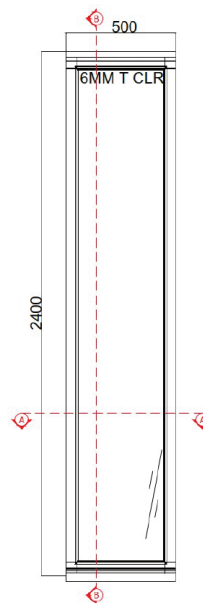

	BAL-12.5	BAL-19	BAL-29	BAL-40
FRAME	Low-level framing must be manufactured from either: <ul style="list-style-type: none"> • Metal, or • Bushfire resistant timber or • Timber species with a density greater than 650 kg/m³ or • Metal reinforced uPVC. 	Low-level framing must be manufactured from either: <ul style="list-style-type: none"> • Metal, or • Bushfire resistant timber or • Timber species with a density greater than 650 kg/m³ or • Metal reinforced uPVC. 	Low-level framing must be manufactured from either: <ul style="list-style-type: none"> • Metal, or • Bushfire resistant timber or • Metal reinforced uPVC. 	All framing must be metal.
GLAZING	Low-level glazing must be Grade A safety glass with a minimum thickness of 4mm.	Low-level glazing must be Grade A safety glass with a minimum thickness of 5mm. In all other locations where annealed glass is used, it must be protected by an external screen (see screen requirements).	All glazing must be toughened glass with a minimum thickness of 5 mm. Low-level glazing must be protected by an external screen (see screen requirements).	All glazing must be toughened glass with a minimum thickness of 6mm. All glazing must be protected by an external screen (see screen requirements).
SCREENS	Openable portions of windows must be screened either internally or externally. Mesh or perforated sheet with a maximum aperture of 2mm manufactured from either: <ul style="list-style-type: none"> - Corrosion resistant steel (Screenguard), or - Bronze, or - Aluminium (Perfguard). Supporting frame must be manufactured from either: <ul style="list-style-type: none"> • Metal (including aluminium), or • Bushfire resistant timber or • Timber species with a density greater than 650 kg/m³. 	Openable portions of windows must be screened either internally or externally. Mesh or perforated sheet with a maximum aperture of 2mm manufactured from either: <ul style="list-style-type: none"> - Corrosion resistant steel (Screenguard), or - Bronze, or - Aluminium (Perfguard). Supporting frame must be manufactured from either: <ul style="list-style-type: none"> • Metal (including aluminium), or • Bushfire resistant timber or • Timber species with a density greater than 650 kg/m³. Where annealed glass is used, it must be protected by an external screen.	Openable portions of windows must be screened either internally or externally. Mesh or perforated sheet with a maximum aperture of 2mm manufactured from either: <ul style="list-style-type: none"> - Corrosion resistant steel (Screenguard), or - Bronze, or - Aluminium (Perfguard). Supporting frame must be manufactured from either: <ul style="list-style-type: none"> • Metal (including aluminium), or • Bushfire resistant timber. Low-level glazing must be protected by an external screen. Screen assemblies must be attached using metal fixings.	Fixed and openable portions of windows must be screened either internally or externally. Mesh or perforated sheet with a maximum aperture of 2mm manufactured from either: <ul style="list-style-type: none"> - Corrosion resistant steel (Screenguard), or - Bronze. Aluminium mesh or perforated sheet cannot be used. Supporting frame must be manufactured from metal (including aluminium). Screen assemblies must be attached using metal fixings.
SEALS	N/A	N/A	N/A	Seals must be manufactured from silicone or have a flammability index less than 5.
HARDWARE	N/A	N/A	Externally fitted hardware that supports the sash in its functions of opening and closing must be metal unless shielded by metal frame components.	Externally fitted hardware that supports the sash in its functions of opening and closing, must be metal.



Mullion Strength Chart: CSG601 + CSG604

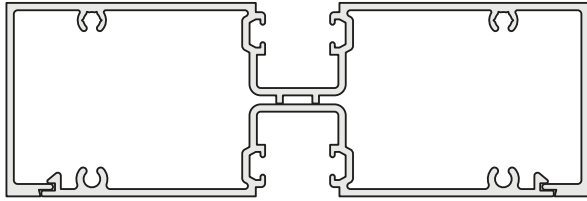

CSG601

CSG604

I - moment of inertia 2483.79 x 10³ mm⁴
 y - max depth of section from N axis 75 mm
 E- Modulus 69 GPa
 Ultimate stress 110 Mpa

Z - Section modulus 33.1

Panel Width Increments 100 mm
 Window Height Increments 100 mm

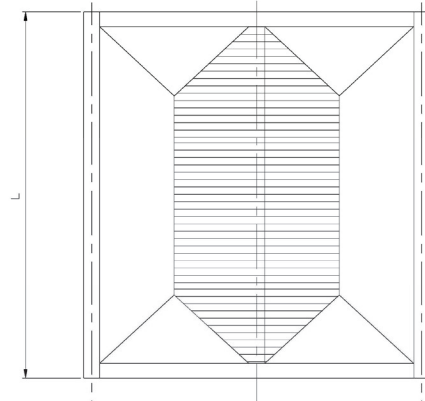

Performance

Mullion Pressure Ratings (Pa): Symmetrical Panels

Darley Aluminium	Serviceability 1/250		Ultimate U		Limitations: Serviceability to 5000Pa & Ultimate to 8000Pa					CSG601 + CSG604
Window Height (mm) (L)	Panel Width (mm) (A)									
	1000	1100	1200	1300	1400	1500	1600	1700	1800	Serviceability
1900	5000	5000	5000	4905	4694	4529	4405	4318	4266	250
	8000	8000	7759	7358	7041	6793	6607	6477	6399	U
2000	5000	4911	4600	4349	4147	3985	3859	3764	3696	250
	7948	7366	6899	6523	6220	5978	5788	5645	5545	U
2100	4766	4408	4120	3885	3694	3539	3414	3316	3241	250
	7149	6612	6180	5828	5541	5308	5121	4974	4862	U
2200	4311	3981	3713	3495	3315	3167	3046	2948	2871	250
	6467	5972	5570	5242	4972	4750	4569	4422	4306	U
2300	3920	3614	3366	3162	2993	2853	2737	2641	2564	250
	5880	5422	5049	4743	4490	4279	4105	3962	3846	U
2400	3580	3297	3066	2876	2718	2585	2475	2383	2306	250
	5370	4946	4600	4314	4076	3878	3712	3574	3460	U
2500	3284	3021	2806	2628	2480	2355	2250	2162	2088	250
	4926	4531	4209	3942	3719	3533	3375	3243	3132	U
2600	3023	2779	2578	2412	2273	2155	2056	1972	1900	250
	4535	4168	3867	3618	3409	3233	3084	2957	2850	U
2700	2793	2485	2332	2205	2091	1981	1887	1806	1738	250
	4189	3847	3566	3333	3137	2971	2830	2710	2607	U
2800	2507	2329	2070	1955	1859	1777	1708	1599	1550	250
	3882	3563	3300	3081	2897	2740	2607	2493	2395	U
2900	2239	2079	1846	1742	1654	1580	1516	1462	1372	250
	3608	3309	3063	2857	2684	2536	2410	2302	2209	U
3000	2009	1864	1744	1558	1478	1411	1352	1302	1259	250
	3363	3082	2850	2657	2494	2355	2236	2133	2044	U
3100	1809	1677	1568	1400	1327	1265	1212	1166	1126	250
	3142	2878	2660	2478	2324	2193	2080	1983	1898	U
3200	1635	1514	1415	1262	1195	1139	1090	1047	1011	250
	2942	2693	2488	2317	2171	2047	1940	1848	1768	U
3300	1482	1372	1281	1205	1081	1029	984	945	911	250
	2761	2526	2333	2171	2034	1916	1815	1727	1650	U
3400	1348	1247	1164	1094	981	932	891	855	824	250
	2596	2375	2192	2039	1909	1797	1701	1618	1545	U
3500	1230	1137	1060	996	941	848	810	776	747	250
	2446	2236	2063	1918	1795	1689	1598	1519	1449	U
3600	1125	1040	969	909	859	773	738	707	680	250
	2308	2110	1946	1808	1691	1591	1504	1429	1363	U
3700	1032	953	888	833	786	707	675	646	621	250
	2182	1994	1838	1708	1597	1501	1419	1347	1284	U
3800	949	876	815	764	721	684	618	592	568	250
	2066	1887	1740	1616	1510	1419	1341	1272	1212	U

Mullion Strength Chart: CSG601 + CSG604

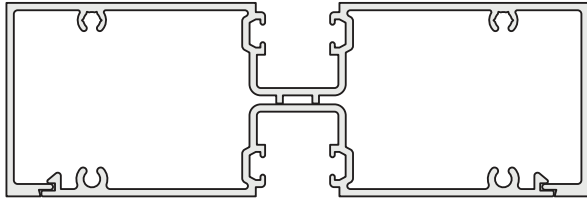

CSG601

CSG604

I - moment of inertia	2483.79	x 10 ³ mm ⁴
y - max depth of section from N axis	75	mm
E- Modulus	69	GPa
Ultimate stress	110	Mpa
Z - Section modulus	33.1	
Panel Width Increments	100	mm
Window Height Increments	100	mm

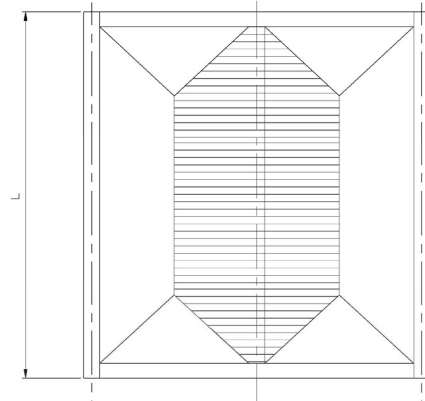

Performance

Mullion Pressure Ratings (Pa): Symmetrical Panels

Darley Aluminium	Panel Width (mm) (A)									Limitations: Serviceability to 5000Pa & Ultimate to 8000Pa	CSG601 + CSG604	
	1200	1300	1400	1500	1600	1700	1800	1900	2000			
Window Height (mm) (L)												
1900	5000	4905	4694	4529	4405	4318	4266	4249	4249	4249	250	U
2000	7759	7358	7041	6793	6607	6477	6399	6373	6373	6373	250	U
2100	4600	4349	4147	3985	3859	3764	3696	3656	3643	3643	250	U
2200	6899	6523	6220	5978	5788	5645	5545	5485	5464	5464	250	U
2300	4120	3885	3694	3539	3414	3316	3241	3189	3157	3157	250	U
2400	6180	5828	5541	5308	5121	4974	4862	4783	4736	4736	250	U
2500	3713	3495	3315	3167	3046	2948	2871	2812	2770	2770	250	U
2600	5570	5242	4972	4750	4569	4422	4306	4218	4155	4155	250	U
2700	3366	3162	2993	2853	2737	2641	2564	2502	2455	2455	250	U
2800	5049	4743	4490	4279	4105	3962	3846	3753	3683	3683	250	U
2900	3066	2876	2718	2585	2475	2383	2306	2244	2195	2195	250	U
3000	4600	4314	4076	3878	3712	3574	3460	3366	3292	3292	250	U
3100	2806	2628	2480	2355	2250	2162	2088	2026	1976	1976	250	U
3200	4209	3942	3719	3533	3375	3243	3132	3039	2964	2964	250	U
3300	2578	2412	2273	2155	2056	1972	1900	1840	1790	1790	250	U
3400	3867	3618	3409	3233	3084	2957	2850	2760	2685	2685	250	U
3500	2332	2205	2091	1981	1887	1806	1738	1680	1631	1631	250	U
3600	3566	3333	3137	2971	2830	2710	2607	2520	2446	2446	250	U
3700	2070	1955	1859	1777	1708	1599	1550	1508	1472	1472	250	U
3800	3300	3081	2897	2740	2607	2493	2395	2311	2239	2239	250	U
3900	1846	1742	1654	1580	1516	1462	1372	1333	1300	1300	250	U
4000	3063	2857	2684	2536	2410	2302	2209	2128	2059	2059	250	U
4100	1744	1558	1478	1411	1352	1302	1259	1185	1154	1154	250	U
4200	2850	2657	2494	2355	2236	2133	2044	1967	1901	1901	250	U
4300	1568	1400	1327	1265	1212	1166	1126	1058	1029	1029	250	U
4400	2660	2478	2324	2193	2080	1983	1898	1825	1761	1761	250	U
4500	1415	1262	1195	1139	1090	1047	1011	979	922	922	250	U
4600	2488	2317	2171	2047	1940	1848	1768	1697	1636	1636	250	U
4700	1281	1205	1081	1029	984	945	911	881	829	829	250	U
4800	2333	2171	2034	1916	1815	1727	1650	1583	1525	1525	250	U
4900	1164	1094	981	932	891	855	824	796	772	772	250	U
5000	2192	2039	1909	1797	1701	1618	1545	1481	1425	1425	250	U
5100	1060	996	941	848	810	776	747	722	700	700	250	U
5200	2063	1918	1795	1689	1598	1519	1449	1389	1335	1335	250	U
5300	969	909	859	773	738	707	680	657	636	636	250	U
5400	1946	1808	1691	1591	1504	1429	1363	1305	1253	1253	250	U
5500	888	833	786	707	675	646	621	599	580	580	250	U
5600	1838	1708	1597	1501	1419	1347	1284	1228	1179	1179	250	U
5700	815	764	721	684	618	592	568	548	530	530	250	U
5800	1740	1616	1510	1419	1341	1272	1212	1159	1112	1112	250	U

Mullion Strength Chart: CSG633 + CSG633

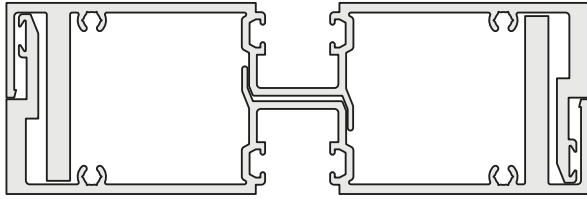

CSG633

CSG633

I - moment of inertia	6013.02	$\times 10^3 \text{ mm}^4$
y - max depth of section from N axis	80.1	mm
E- Modulus	69	GPa
Ultimate stress	110	Mpa
Z - Section modulus	75.1	
Panel Width Increments	100	mm
Window Height Increments	100	mm

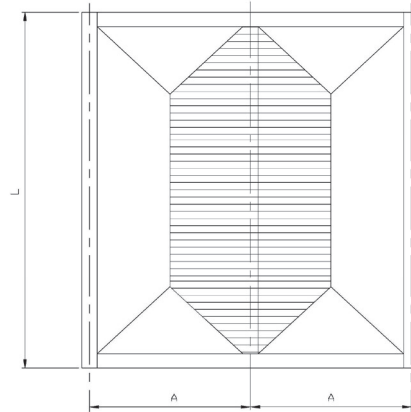

Performance

Mullion Pressure Ratings (Pa): Symmetrical Panels

Darley Aluminium	Serviceability 1/250		Ultimate	U	Limitations: Serviceability to 5000Pa & Ultimate to 8000Pa					CSG633 + CSG633
Panel Width (mm) (A)										
Window Height (mm) (L)	1000	1100	1200	1300	1400	1500	1600	1700	1800	Serviceability
2500	5000	5000	5000	5000	5000	5000	5000	4900	4732	250
	8000	8000	8000	8000	8000	8000	7651	7350	7099	U
2600	5000	5000	5000	5000	5000	4885	4660	4469	4308	250
	8000	8000	8000	8000	7727	7328	6990	6704	6461	U
2700	5000	5000	5000	5000	4740	4489	4276	4095	3940	250
	8000	8000	8000	7554	7110	6734	6414	6142	5910	U
2800	5000	5000	4986	4656	4377	4141	3940	3767	3619	250
	8000	8000	7480	6983	6566	6212	5910	5651	5429	U
2900	5000	5000	4469	4217	4004	3824	3643	3479	3322	250
	8000	7501	6942	6476	6083	5749	5464	5218	5007	U
3000	4863	4511	4222	3772	3579	3415	3274	3153	3049	250
	7622	6986	6461	6023	5653	5338	5068	4835	4634	U
3100	4379	4059	3795	3389	3212	3062	2933	2822	2726	250
	7121	6523	6030	5617	5268	4971	4715	4494	4303	U
3200	3958	3666	3425	3056	2894	2756	2638	2536	2447	250
	6668	6105	5640	5251	4922	4641	4399	4189	4007	U
3300	3589	3322	3101	2917	2617	2490	2381	2287	2205	250
	6258	5727	5288	4921	4610	4343	4114	3915	3741	U
3400	3264	3019	2817	2648	2374	2257	2157	2070	1994	250
	5884	5383	4968	4621	4326	4074	3856	3667	3502	U
3500	2978	2753	2567	2411	2279	2053	1960	1880	1809	250
	5544	5069	4677	4348	4069	3830	3623	3443	3286	U
3600	2724	2517	2345	2202	2080	1872	1786	1712	1647	250
	5232	4783	4411	4099	3834	3607	3410	3239	3089	U
3700	2498	2307	2149	2016	1903	1712	1633	1564	1503	250
	4946	4520	4167	3871	3619	3403	3216	3053	2910	U
3800	2296	2120	1973	1851	1746	1656	1496	1432	1376	250
	4683	4278	3943	3662	3423	3217	3039	2883	2747	U
3900	2116	1952	1817	1703	1606	1523	1375	1315	1263	250
	4441	4056	3737	3469	3242	3046	2876	2728	2597	U
4000	1954	1802	1676	1570	1480	1403	1336	1211	1162	250
	4217	3851	3547	3292	3075	2888	2726	2584	2460	U
4100	1808	1667	1550	1451	1368	1295	1233	1117	1071	250
	4009	3660	3371	3128	2921	2742	2588	2452	2333	U
4200	1677	1545	1436	1344	1266	1199	1140	1032	990	250
	3817	3484	3208	2976	2778	2607	2460	2330	2216	U
4300	1557	1435	1333	1247	1174	1111	1057	1009	917	250
	3638	3320	3057	2835	2645	2483	2341	2217	2108	U
4400	1449	1335	1239	1159	1091	1032	981	937	850	250
	3472	3168	2916	2703	2522	2366	2231	2112	2008	U

Mullion Strength Chart: CSG633 + CSG633

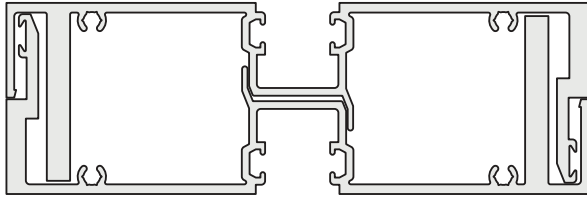

I - moment of inertia 6013.02 x 10³ mm⁴
 y - max depth of section from N axis 80.1 mm
 E- Modulus 69 GPa
 Ultimate stress 110 Mpa
 Z - Section modulus 75.1
 Panel Width Increments 100 mm
 Window Height Increments 100 mm

CSG633

CSG633

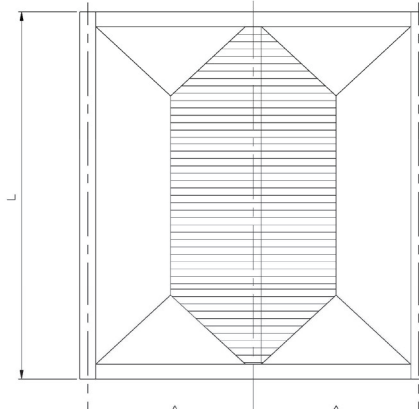

Performance

Mullion Pressure Ratings (Pa): Symmetrical Panels

Darley Aluminium	Serviceability 1/250		Ultimate U		Limitations: Serviceability to 5000Pa & Ultimate to 8000Pa					CSG633 + CSG633
Window Height (mm) (L)	Panel Width (mm) (A)									
	1200	1300	1400	1500	1600	1700	1800	1900	2000	Serviceability
2600	5000	5000	5000	4885	4660	4469	4308	4171	4058	250
	8000	8000	7727	7328	6990	6704	6461	6257	6087	U
2700	5000	5000	4740	4489	4276	4095	3940	3808	3697	250
	8000	7554	7110	6734	6414	6142	5910	5712	5545	U
2800	4986	4656	4377	4141	3940	3767	3619	3493	3384	250
	7480	6983	6566	6212	5910	5651	5429	5239	5076	U
2900	4469	4217	4004	3824	3643	3479	3322	3216	3112	250
	6942	6476	6083	5749	5464	5218	5007	4825	4667	U
3000	4222	3772	3579	3415	3274	3153	3049	2869	2794	250
	6461	6023	5653	5338	5068	4835	4634	4459	4308	U
3100	3795	3389	3212	3062	2933	2822	2726	2562	2492	250
	6030	5617	5268	4971	4715	4494	4303	4136	3991	U
3200	3425	3056	2894	2756	2638	2536	2447	2369	2232	250
	5640	5251	4922	4641	4399	4189	4007	3848	3708	U
3300	3101	2917	2617	2490	2381	2287	2205	2133	2008	250
	5288	4921	4610	4343	4114	3915	3741	3589	3456	U
3400	2817	2648	2374	2257	2157	2070	1994	1928	1869	250
	4968	4621	4326	4074	3856	3667	3502	3357	3230	U
3500	2567	2411	2279	2053	1960	1880	1809	1748	1693	250
	4677	4348	4069	3830	3623	3443	3286	3147	3026	U
3600	2345	2202	2080	1872	1786	1712	1647	1590	1539	250
	4411	4099	3834	3607	3410	3239	3089	2957	2841	U
3700	2149	2016	1903	1712	1633	1564	1503	1450	1403	250
	4167	3871	3619	3403	3216	3053	2910	2784	2673	U
3800	1973	1851	1746	1656	1496	1432	1376	1327	1283	250
	3943	3662	3423	3217	3039	2883	2747	2627	2520	U
3900	1817	1703	1606	1523	1375	1315	1263	1217	1176	250
	3737	3469	3242	3046	2876	2728	2597	2482	2380	U
4000	1676	1570	1480	1403	1336	1211	1162	1119	1080	250
	3547	3292	3075	2888	2726	2584	2460	2350	2252	U
4100	1550	1451	1368	1295	1233	1117	1071	1031	995	250
	3371	3128	2921	2742	2588	2452	2333	2228	2134	U
4200	1436	1344	1266	1199	1140	1032	990	952	919	250
	3208	2976	2778	2607	2460	2330	2216	2115	2026	U
4300	1333	1247	1174	1111	1057	1009	917	881	850	250
	3057	2835	2645	2483	2341	2217	2108	2011	1925	U
4400	1239	1159	1091	1032	981	937	850	817	788	250
	2916	2703	2522	2366	2231	2112	2008	1915	1832	U
4500	1155	1080	1016	961	913	871	834	759	732	250
	2785	2581	2408	2258	2129	2015	1914	1825	1746	U

Glass & Rubber Combinations

Glazing

100/150mm x 50mm CENTRE/FRONT SG			
Glass Thickness	Specific Profiles Required	Wedge Required	Pocket Size
6mm		1615 – 1615 1620 – 1645	16.75mm
8mm		1620 – 1620 1625 – 1645	
10mm		1620 – 1646	
12mm		1630 – 1630 1630 – 1647	

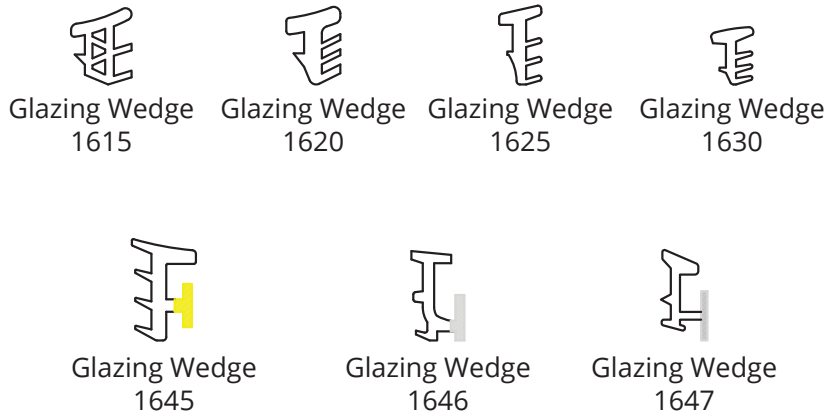

Glazing

General Configuration

All raw joints need to be sealed with small joint sealer or foam tab option.

Configuration

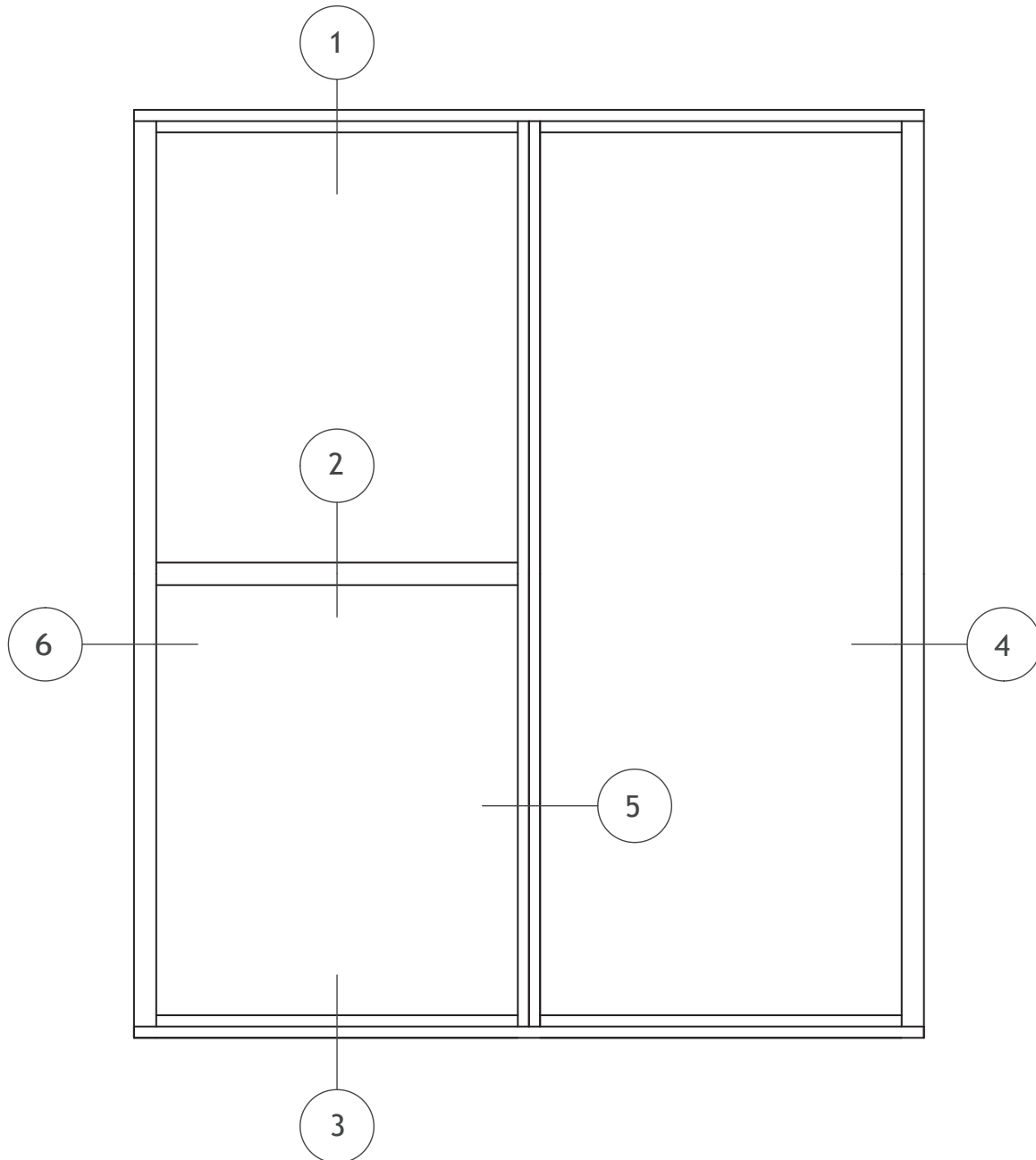

Fabrication

Copyright and important information on page 3

Energy Rating Definitions

All Darley products have been rated under the Australian Fenestration Ratings Council (AFRC) Energy Rating Scheme.

Definitions

The following are terms used in describing the energy ratings of windows as defined by the Window Energy Rating Scheme (WERS). For further information go to www.wers.net.

U-Value (U_w)

U-Value measures how well a product prevents heat from escaping. It is a measure of the rate of non solar heat loss or gain through a material or assembly. U-Value ratings generally fall between 2.0 - 10.0 W/m² for Australian products. The rate of heat is indicated in the terms of the U-Value of a window assembly which includes the effect of the frame, glass, seals and any spacers. The lower the U-value, the greater a window's resistance to heat flow and the better its insulating value. The U-Value for a window takes account for the various U-values for the components making up the window, so you may see these in technical literature:

U_w is the value for the whole window and because of its importance is usually abbreviated to U.

U_c is the value at the centre of glass.

U_f is the value for the frame.

Solar Heat Gain Coefficient (SHGC_w)

SHGC measures how well a product blocks heat caused by sunlight. The SHGC is a fraction of incident solar radiation admitted through a window, both directly transmitted, and absorbed and subsequently released inward. SHGC is expressed as a number between 0 and 1. The lower a window's SHGC, the less solar heat it transmits.

Visible Transmittance (T_{vw})

Visible transmittance measures how much light comes in through a product. It is an optical property that indicates the amount of visible light transmitted. T_{vw} is expressed as a number between 0 and 1. The higher the number, the more light is transmitted.

Energy Rating: CityView 100mm Centre Single Glazed

Window Id	Glass Supplier	Glass	Uw	SHGCw	TVw	Air Infil.
DAR-072-043	OCEANIA	6SpGy	6.028	0.32	0.076	0.09
DAR-072-042	OCEANIA	6SpGn	6.028	0.476	0.597	0.09
DAR-072-040	OCEANIA	6SolTNtl	4.19	0.482	0.567	0.09
DAR-072-041	OCEANIA	6SolTGy	4.219	0.333	0.273	0.09
DAR-072-027	VIRIDIAN	6Sn	4.511	0.532	0.62	0.09
DAR-072-044	<UNKNOWN>	6Pb	4.242	0.629	0.725	0.09
DAR-072-039	<UNKNOWN>	6i89	4.162	0.656	0.779	0.09
DAR-072-038	OCEANIA	6Gy	6.028	0.524	0.374	0.09
DAR-072-037	OCEANIA	6Gn	6.028	0.556	0.688	0.09
DAR-072-036	OCEANIA	6EVSpGn	4.356	0.336	0.44	0.09
DAR-072-029	OCEANIA	6EVSpBl	4.338	0.329	0.347	0.09
DAR-072-030	OCEANIA	6EVGy	4.338	0.372	0.287	0.09
DAR-072-035	OCEANIA	6EvGn	4.226	0.251	0.256	0.09
DAR-072-034	OCEANIA	6EVClr	4.338	0.564	0.597	0.09
DAR-072-032	OCEANIA	6EVBz	4.338	0.411	0.339	0.09
DAR-072-033	OCEANIA	6EVBG	4.226	0.294	0.291	0.09
DAR-072-031	OCEANIA	6ET	4.171	0.63	0.73	0.09
DAR-072-028	GENERIC	6Clr	6.028	0.744	0.791	0.09
DAR-072-026	OCEANIA	6AB	6.028	0.47	0.471	0.09
DAR-072-023	OCEANIA	6.38TransLam	5.978	0.611	0.598	0.09
DAR-072-024	OCEANIA	6.38GyLam	5.978	0.559	0.395	0.09
DAR-012-004	OCEANIA	6.38CPNtl	4.499	0.467	0.517	0.07
DAR-072-020	OCEANIA	6.38CPNtl	4.194	0.465	0.527	0.09
DAR-072-019	OCEANIA	6.38CPGy	4.165	0.449	0.349	0.09
DAR-072-021	OCEANIA	6.38CPGn	4.166	0.457	0.637	0.09
DAR-072-022	OCEANIA	6.38CPClr	4.166	0.618	0.735	0.09
DAR-072-025	GENERIC	6.38ClrLam	5.978	0.709	0.784	0.09
DAR-072-046	<UNKNOWN>	5PbG	4.286	0.642	0.732	0.09
DAR-072-045	GENERIC	5Clr	6.06	0.749	0.794	0.09
DAR-072-048	VIRIDIAN	4Sn	4.632	0.526	0.598	0.09
DAR-072-049	<UNKNOWN>	4Pb	4.328	0.659	0.739	0.09
DAR-072-047	GENERIC	4Clr	6.092	0.785	0.809	0.09
DAR-072-002	<UNKNOWN>	12Gy	5.844	0.403	0.173	0.09
DAR-072-001	OCEANIA	12Clr	5.844	0.657	0.755	0.09

KEY

Lam = Laminate, Sp = Super, EV = Eantage, CP = Comfort Plus, Ntl = Neutral, Pb = Planibel G, SolT - SolTech, ET = Energy Tech, Sn = Sunergy, LE = Low E, i89 = i89, Clr = Clear, Gy = Grey, Gn = Green, B = Blue, Bz = Bronze, BG = Blue Green, AB = Arctic Blue, Trans = Translucent,

NOTES

- Percentage improvement figures are compared with using base-case Generic Window 1 (3mm clear in standard aluminium frame)
- A negative percentage improvement figure indicates performance worse than the base-case window
- A positive percentage improvement figure indicates performane better than the base-case window
- Maximum air infiltration is 5.0 L/s.m² at a positive pressure difference of 75Pa as measured according to AS 2047
- Static performance (U, SHFC, Tw, Tdw) Calculated using Window 5.2 and Therm 5.2 software (LBNL), 2000-2003
- Annual energy performance (stars and % improvements) calculated using Nationwide House Energy Rating Software (AccuRate)
- Results disclosed at National fenestration Rating Council (AFRC) regulations

Glazing

Window Id	Glass Supplier	Glass	Uw	SHGCw	TVw	Air Infil.
DAR-072-004	OCEANIA	12.38GyLam	5.809	0.528	0.385	0.09
DAR-072-003	OCEANIA	12.38ClrLam	5.809	0.664	0.763	0.09
DAR-072-050	<UNKNOWN>	11.52LE	4.053	0.561	0.703	0.09
DAR-072-005	GENERIC	11.52ClrLam	5.722	0.655	0.764	0.09
DAR-072-014	OCEANIA	10SolTNtl	4.16	0.471	0.553	0.09
DAR-072-017	VIRIDIAN	10Sn	4.472	0.526	0.61	0.09
DAR-072-016	OCEANIA	10Gy	5.904	0.432	0.222	0.09
DAR-072-015	OCEANIA	10ET	4.13	0.594	0.709	0.09
DAR-072-018	GENERIC	10Clr	5.904	0.679	0.765	0.09
DAR-072-006	OCEANIA	10.38SpGn	5.868	0.463	0.59	0.09
DAR-072-009	OCEANIA	10.38GyLam	5.868	0.532	0.388	0.09
DAR-072-008	OCEANIA	10.38EVSpGn	4.27	0.329	0.435	0.09
DAR-072-007	OCEANIA	10.38EVGy	4.252	0.358	0.284	0.09
DAR-072-013	OCEANIA	10.38CPNtl	4.109	0.459	0.561	0.09
DAR-072-010	OCEANIA	10.38CPGy	4.091	0.437	0.364	0.09
DAR-072-012	OCEANIA	10.38CPClr	4.122	0.569	0.707	0.09
DAR-072-011	OCEANIA	10.38Clr	5.868	0.67	0.768	0.09

KEY

Lam = Laminate, Sp = Super, EV = Eantage, CP = Comfort Plus, Ntl = Neutral, Pb = Planibel G, SolT - SolTech, ET = Energy Tech, Sn = Sunergy, LE = Low E, i89 = i89, Clr = Clear, Gy = Grey, Gn = Green, B = Blue, Bz = Bronze, BG = Blue Green, AB = Arctic Blue, Trans = Translucent,

NOTES

1. Percentage improvement figures are compared with using base-case Generic Window 1 (3mm clear in standard aluminium frame)
2. A negative percentage improvement figure indicates performance worse than the base-case window
3. A positive percentage improvement figure indicates performane better than the base-case window
4. Maximum air infiltration is 5.0 L/s.m² at a positive pressure difference of 75Pa as measured according to AS 2047
5. Static performance (U, SHFC, Tw, Tdw) Calculated using Window 5.2 and Therm 5.2 software (LBNL), 2000-2003
6. Annual energy performance (stars and % improvements) calculated using Nationwide House Energy Rating Software (AccuRate)
7. Results disclosed at National fenestration Rating Council (AFRC) regulations

All raw joints need to be sealed with small joint sealer or foam tab option.

Cross Sections

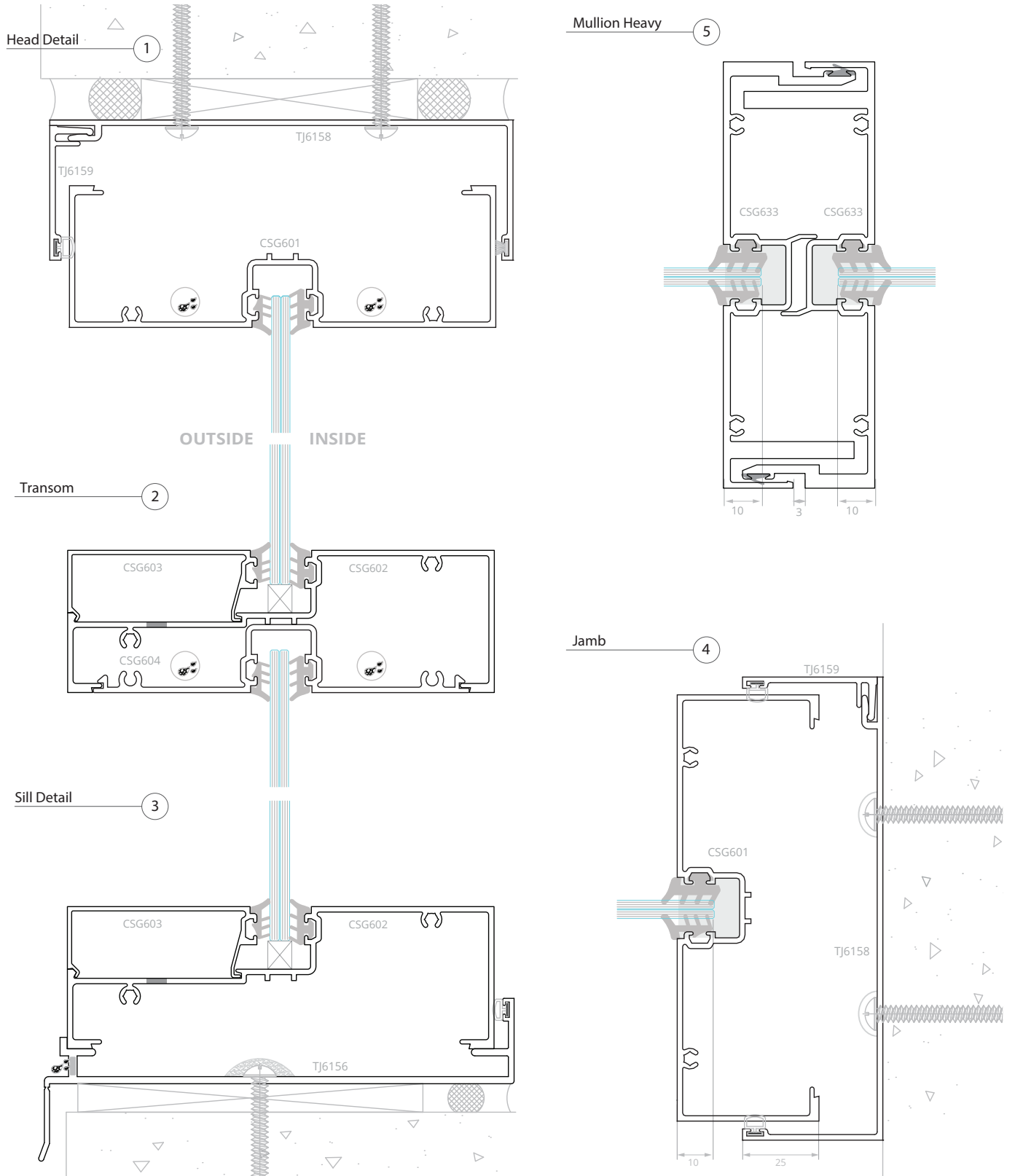

Fabrication

Copyright and important information on page 3

Head & Sill Option

All raw joints need to be sealed with small joint sealer or foam tab option.

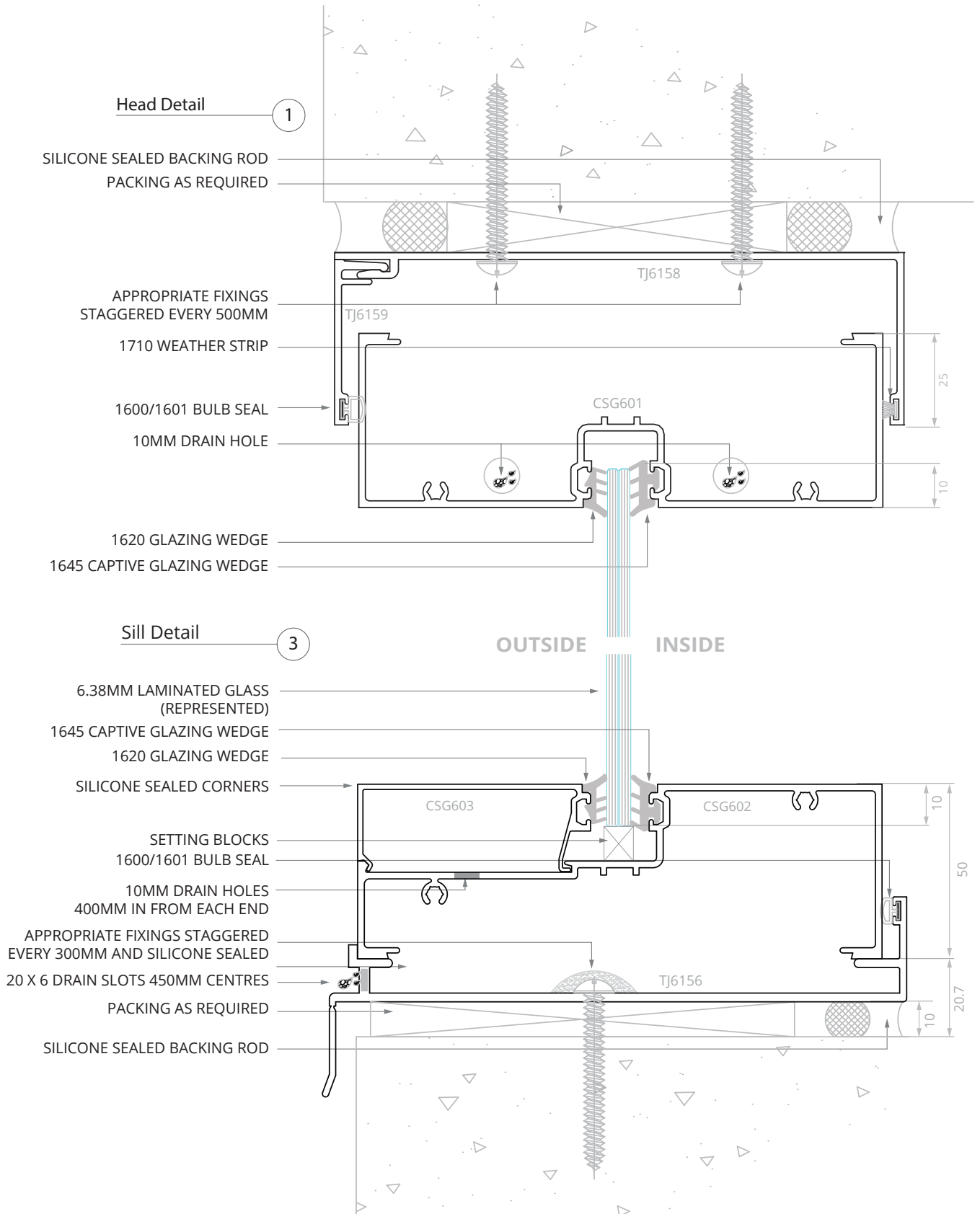

Copyright and important information on page 3

Head & Sill Option

All raw joints need to be sealed with small joint sealer or foam tab option.

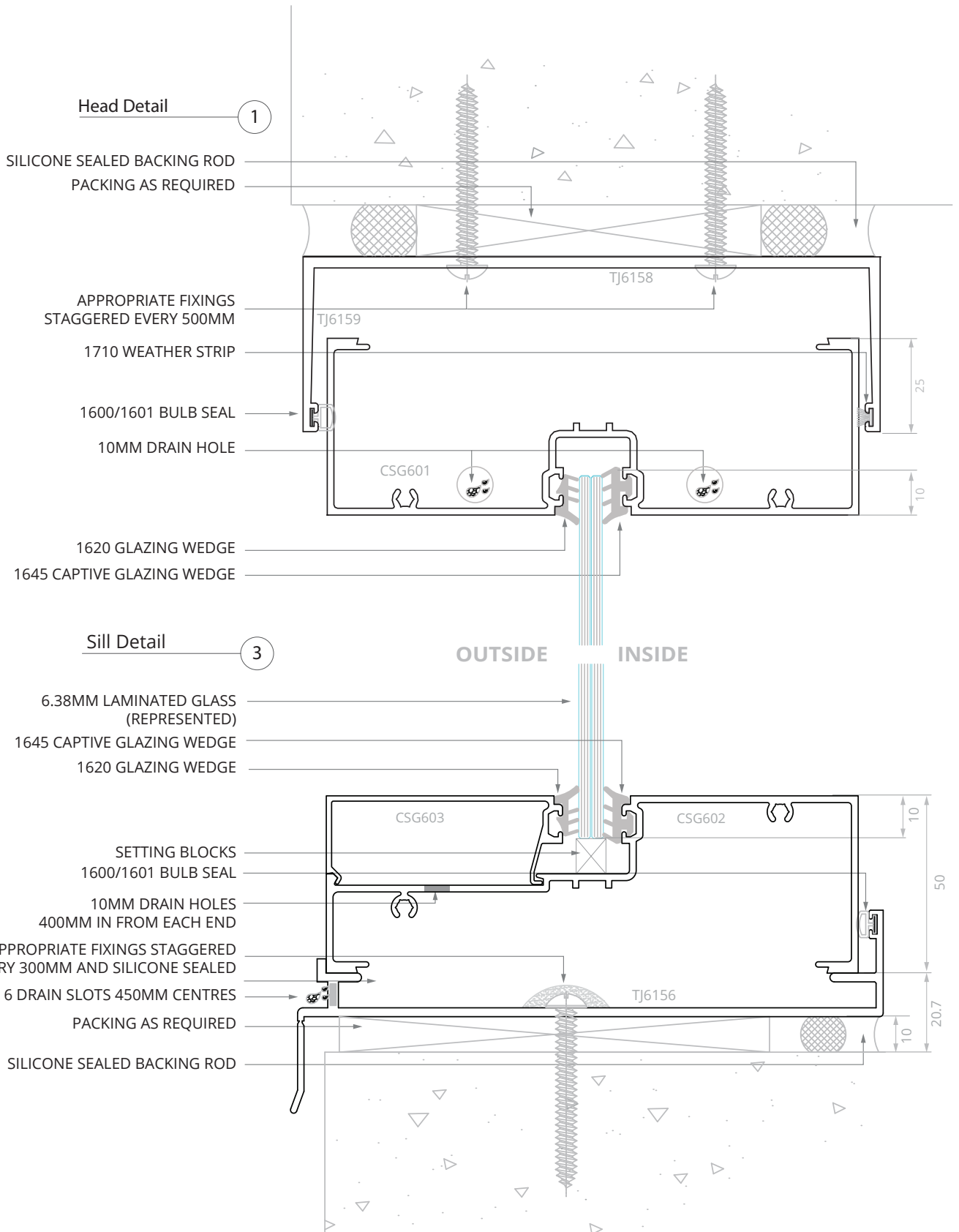

Fabrication

Copyright and important information on page 3

Transom Option

All raw joints need to be sealed with small joint sealer or foam tab option.

Fabrication

Transom ②

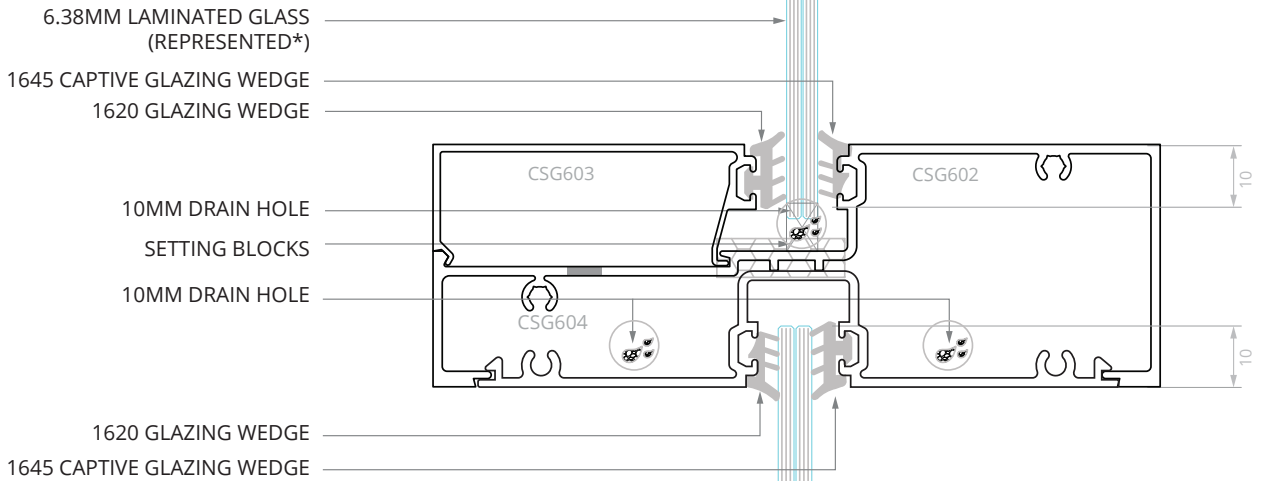

Sill Detail ③

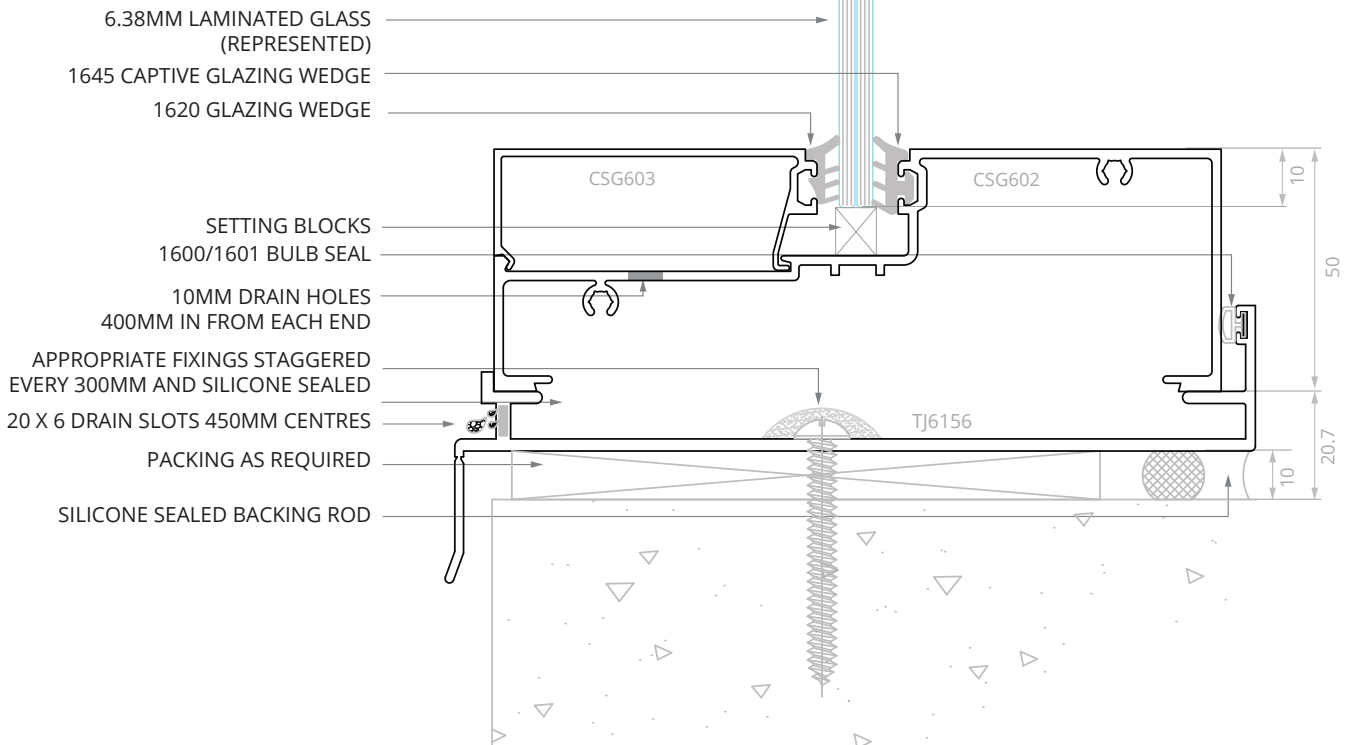

Copyright and important information on page 3

Jamb Option: Sub Jamb

All raw joints need to be sealed with small joint sealer or foam tab option.

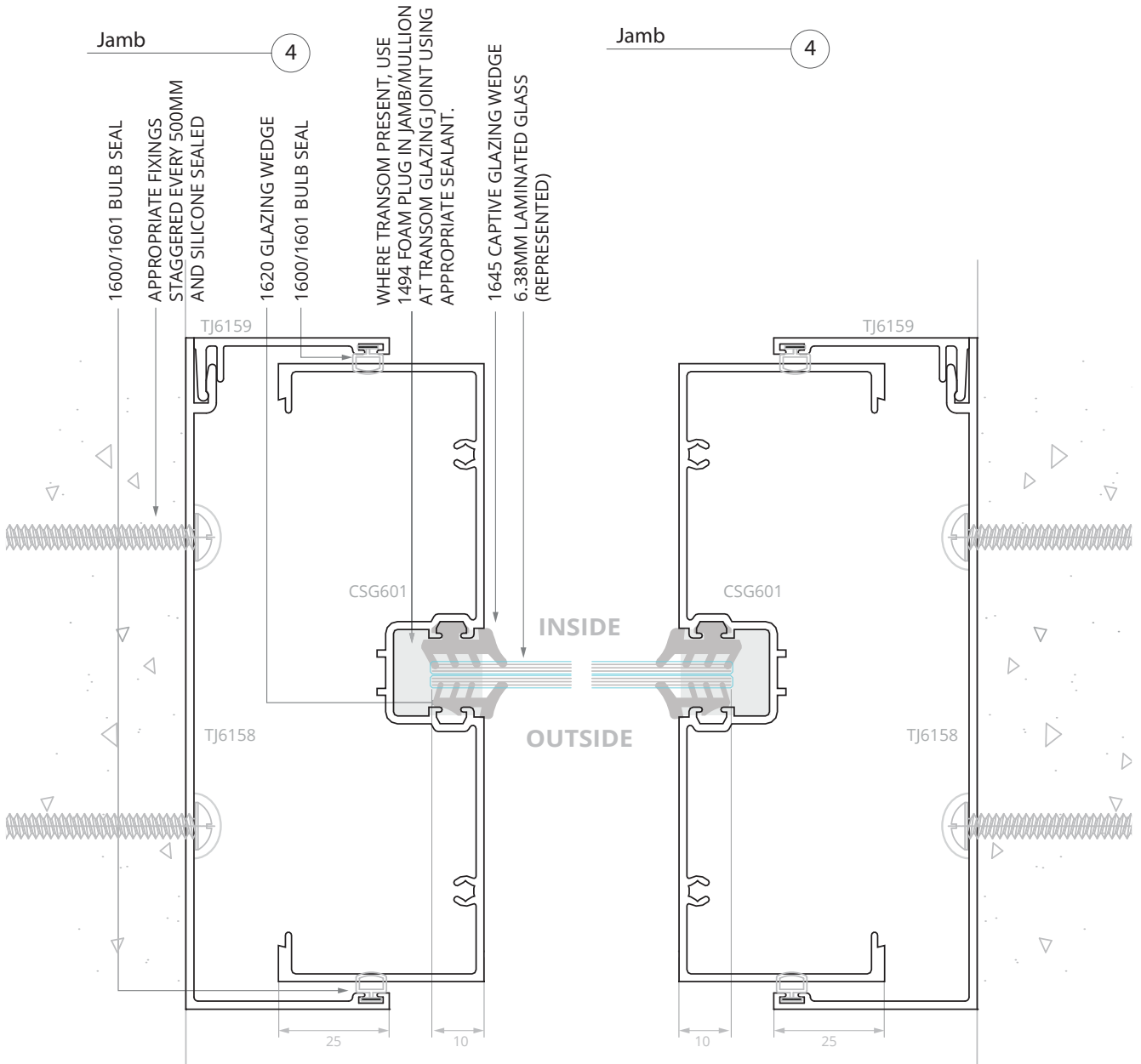

Fabrication

Copyright and important information on page 3

Jamb Option: Angle

All raw joints need to be sealed with small joint sealer or foam tab option.

Fabrication

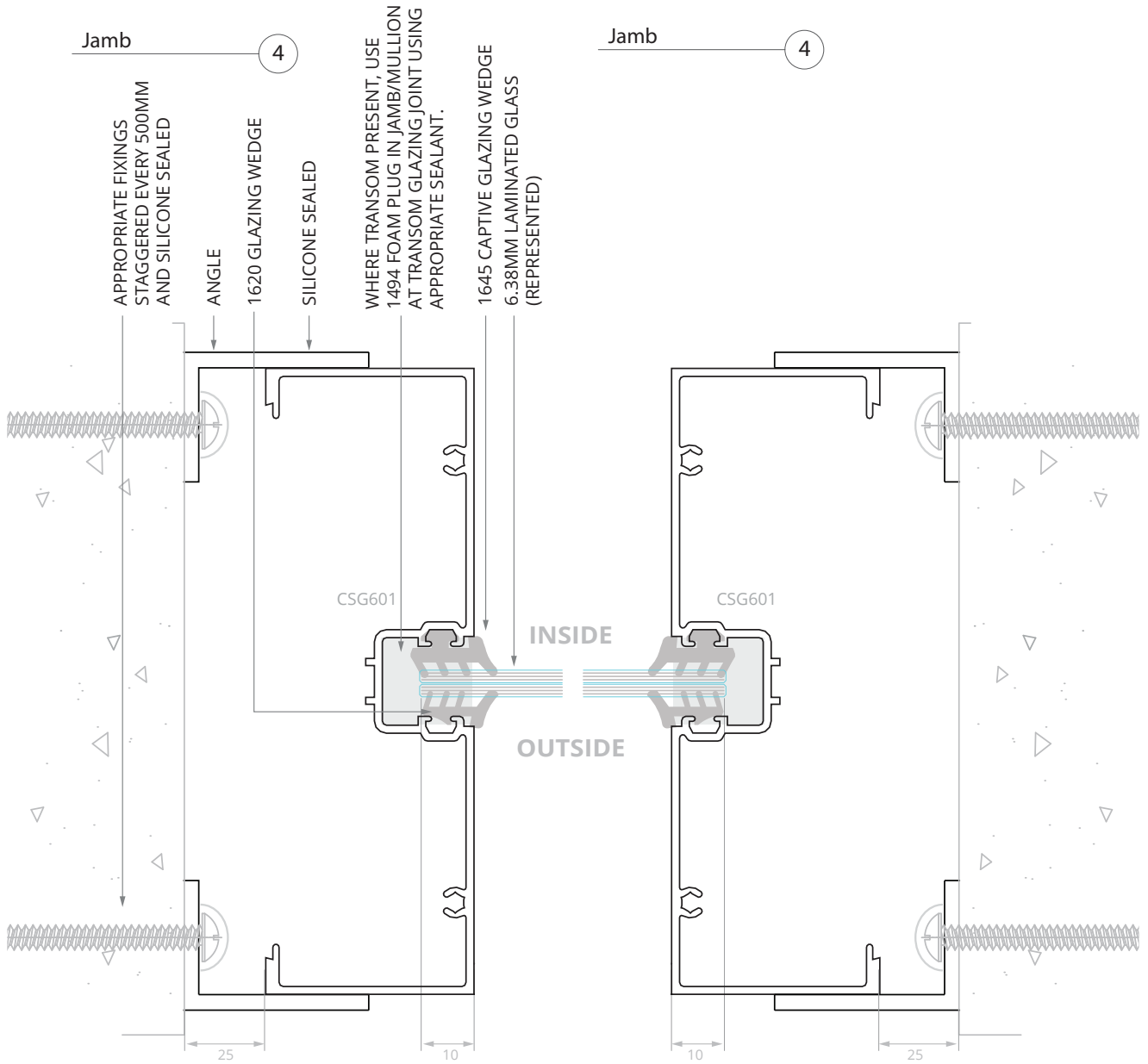

Copyright and important information on page 3

Mullion

All raw joints need to be sealed with small joint sealer or foam tab option.

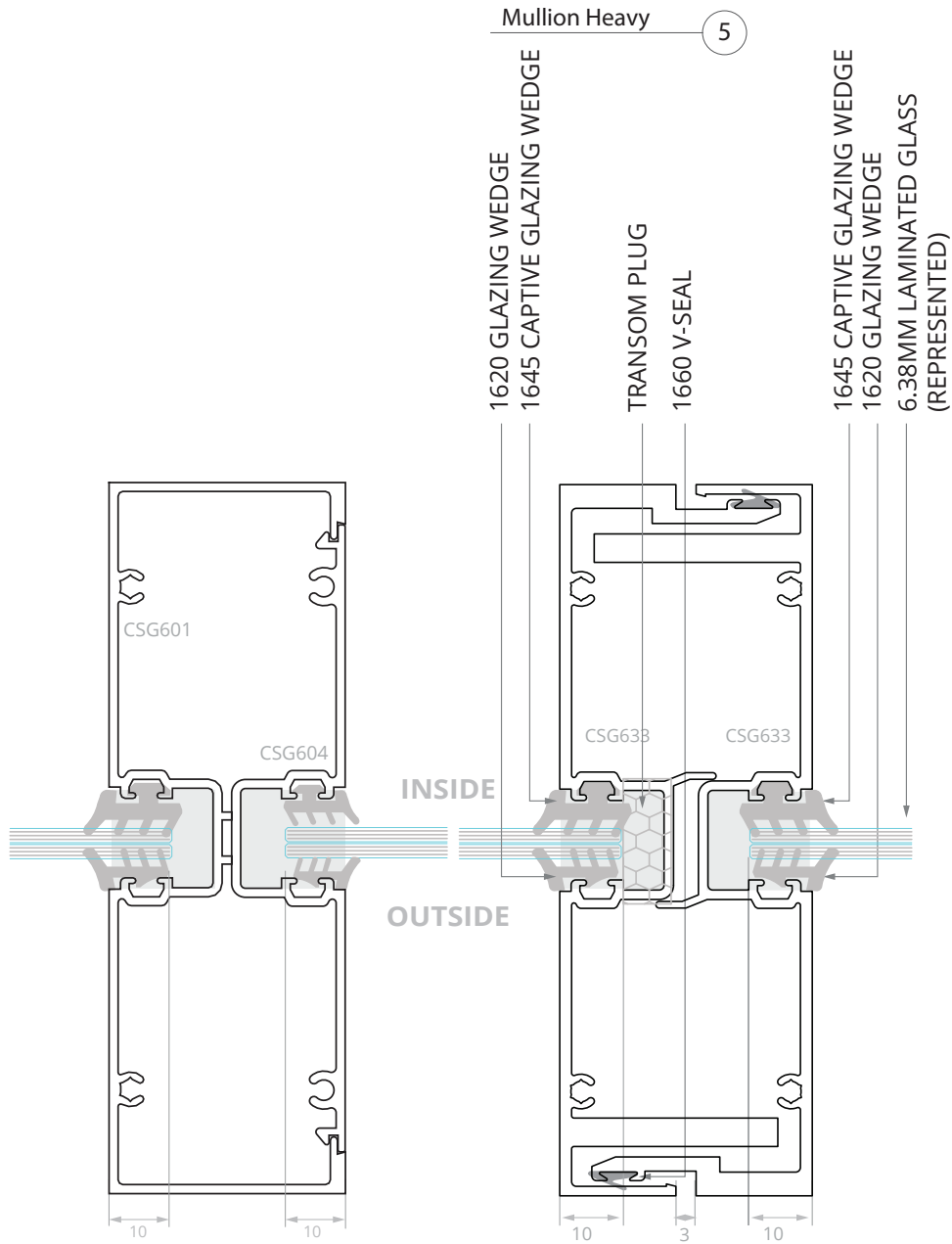

Fabrication

CityView 35mm awning

Scale 1:1

For more information on this configuration, please see relevant technical manual

Fabrication

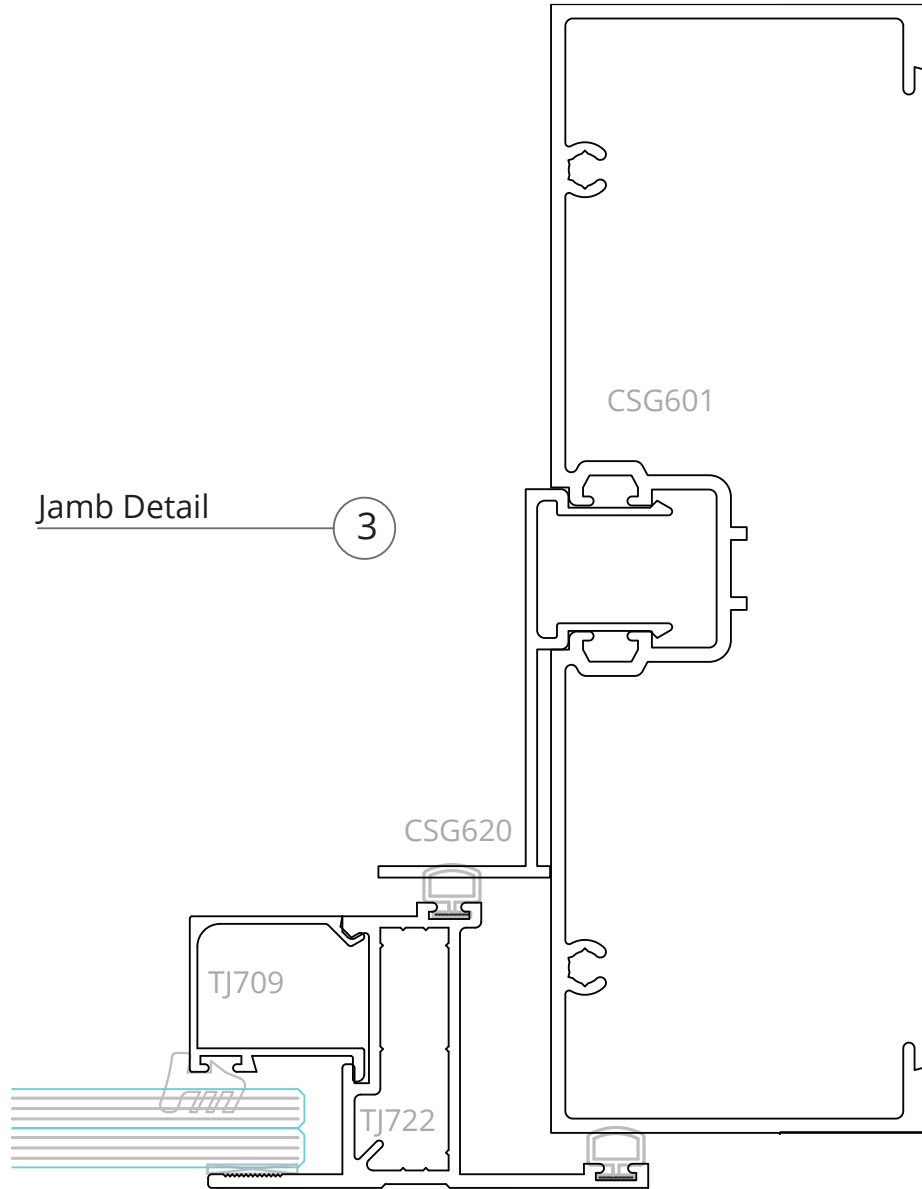

Copyright and important information on page 3

CityView 50mm Hook Awning

Scale 1:1

All raw joints need to be sealed with small joint sealer or foam tab option.

For more information on this configuration, please see relevant technical manual

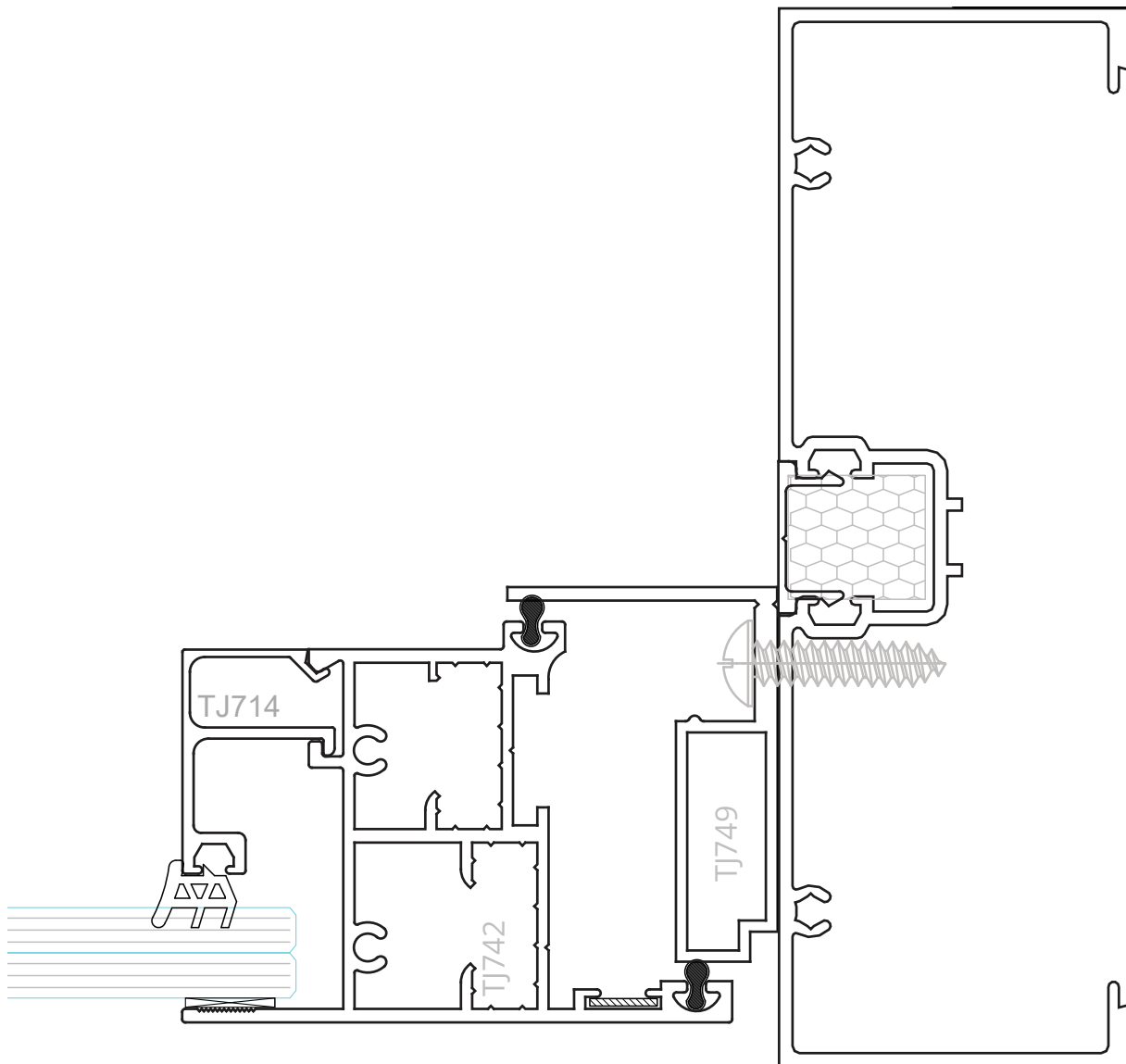

Fabrication

Copyright and important information on page 3

CityView Truth Awning

All raw joints need to be sealed with small joint sealer or foam tab option.

Scale 1:1

For more information on this configuration, please see relevant technical manual

Fabrication

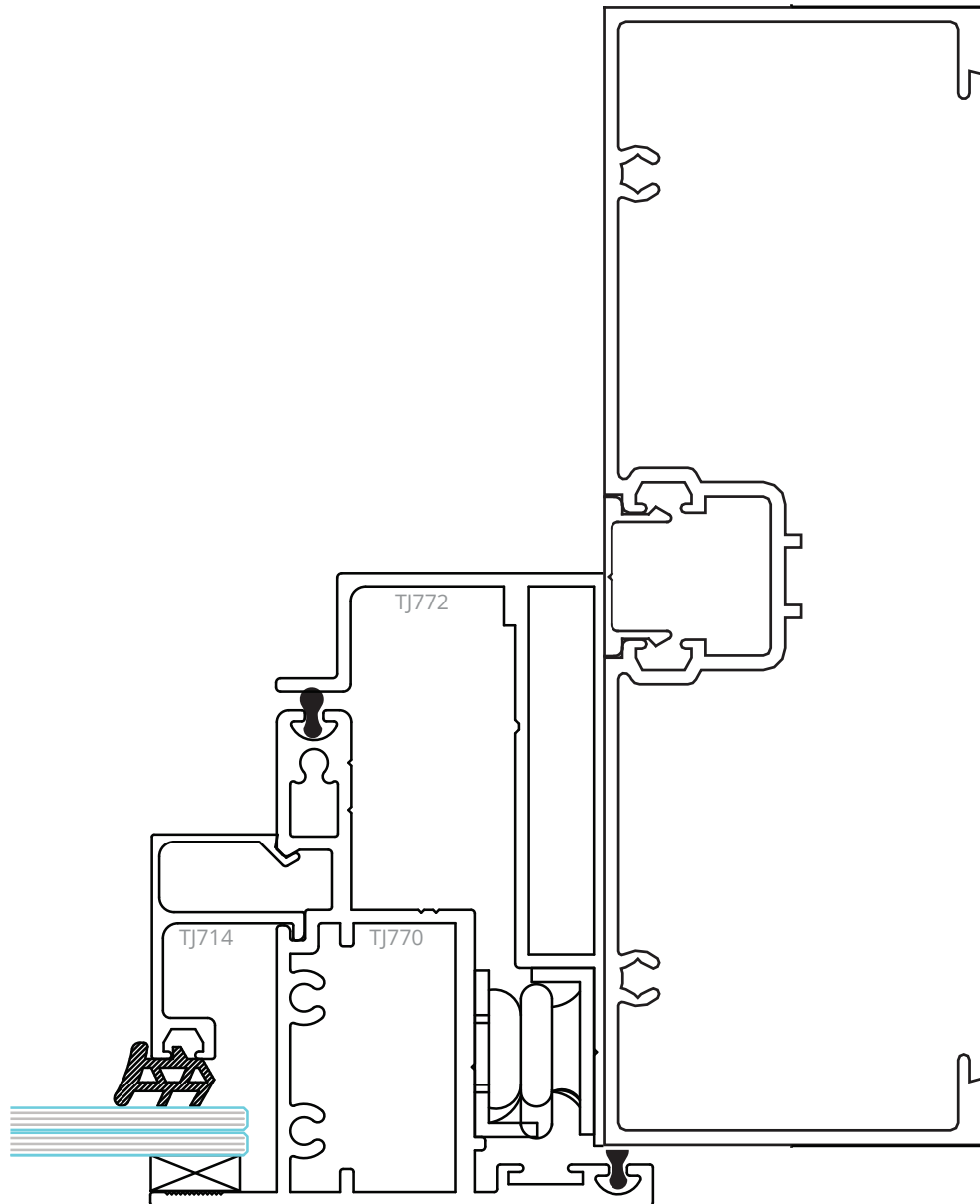

Copyright and important information on page 3

CityView 40/44mm Hinge Door

Scale 1:1

All raw joints need to be sealed with small joint sealer or foam tab option.

For more information on this configuration, please see relevant technical manual

Fabrication

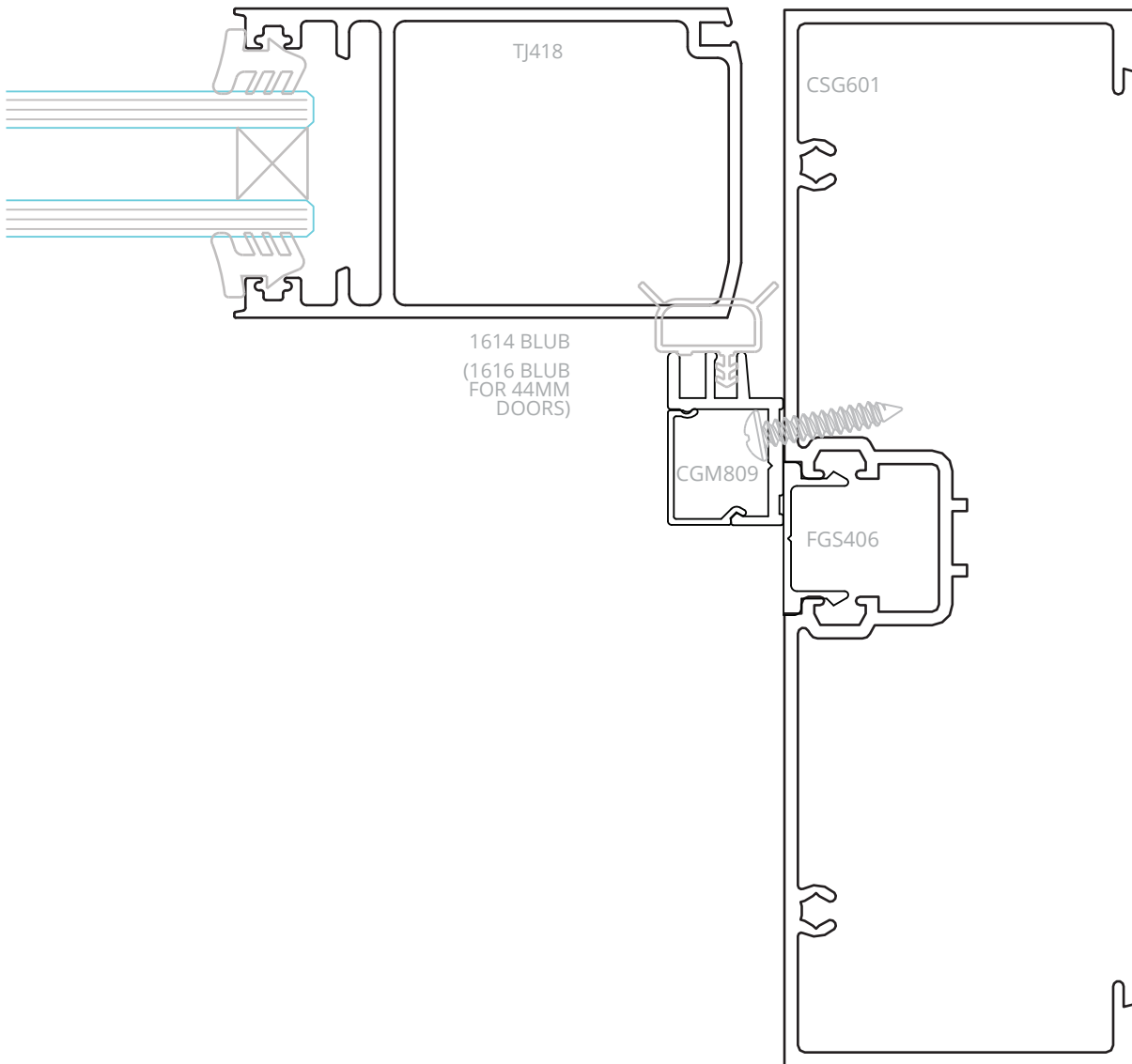

Copyright and important information on page 3

CityView 45mm Hinge Door

Scale 1:1

For more information on this configuration,
please see relevant technical manual

Fabrication

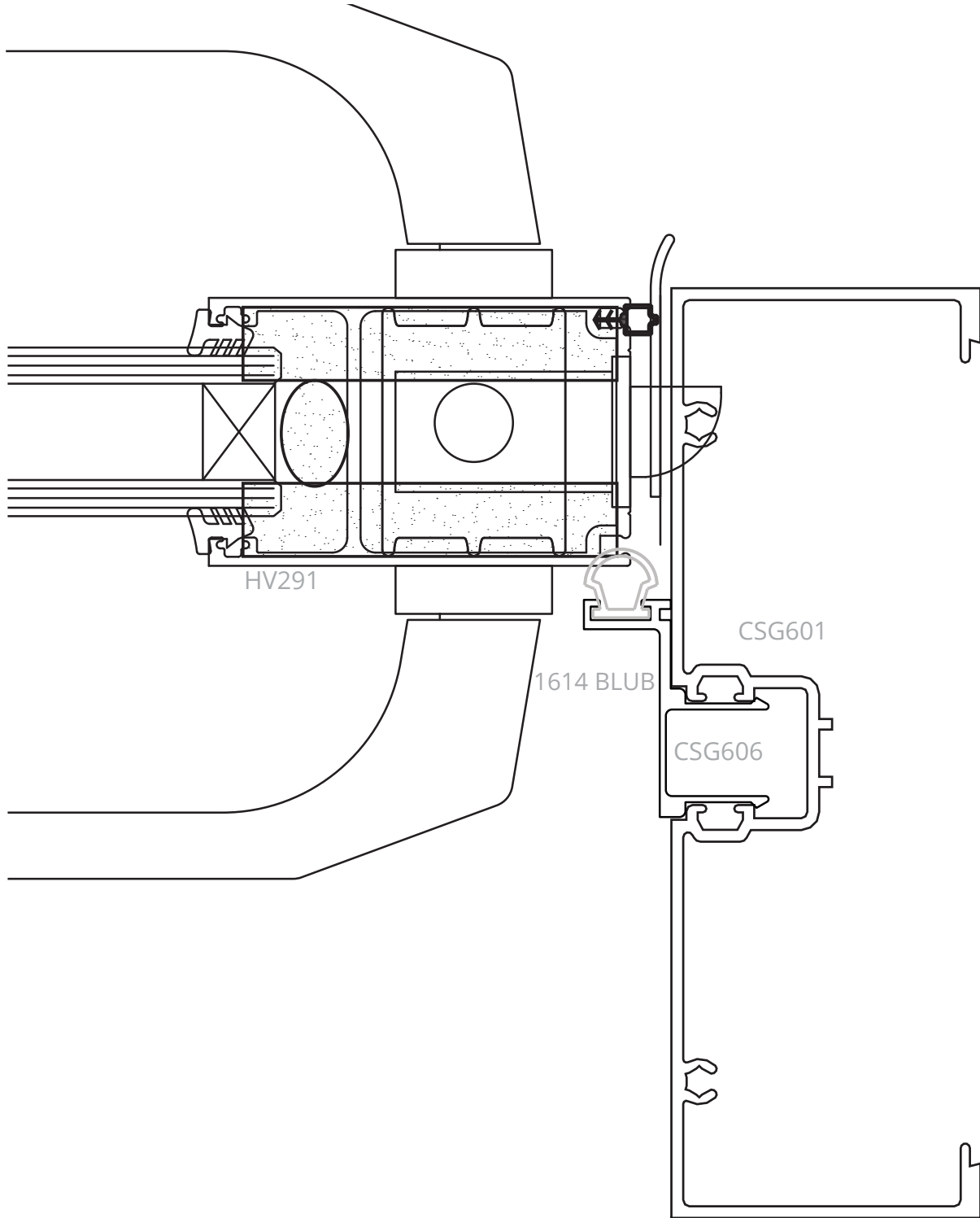

Copyright and important information on page 3

CityView Architectural Sliding Door

Scale 1:1

For more information on this configuration, please see relevant technical manual

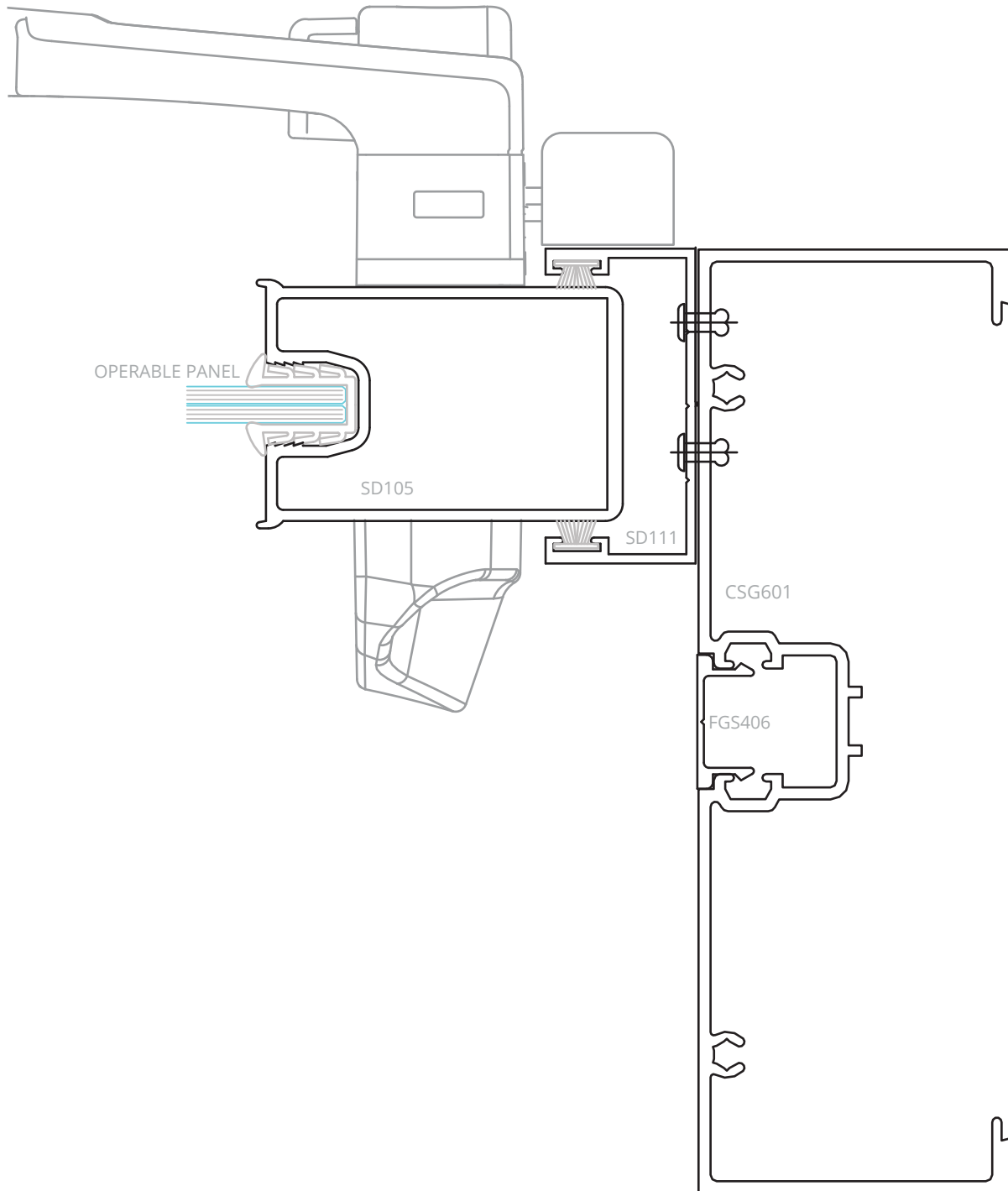

Fabrication

Copyright and important information on page 3

Cutting Formula

All raw joints need to be sealed with small joint sealer or foam tab option.

Fabrication

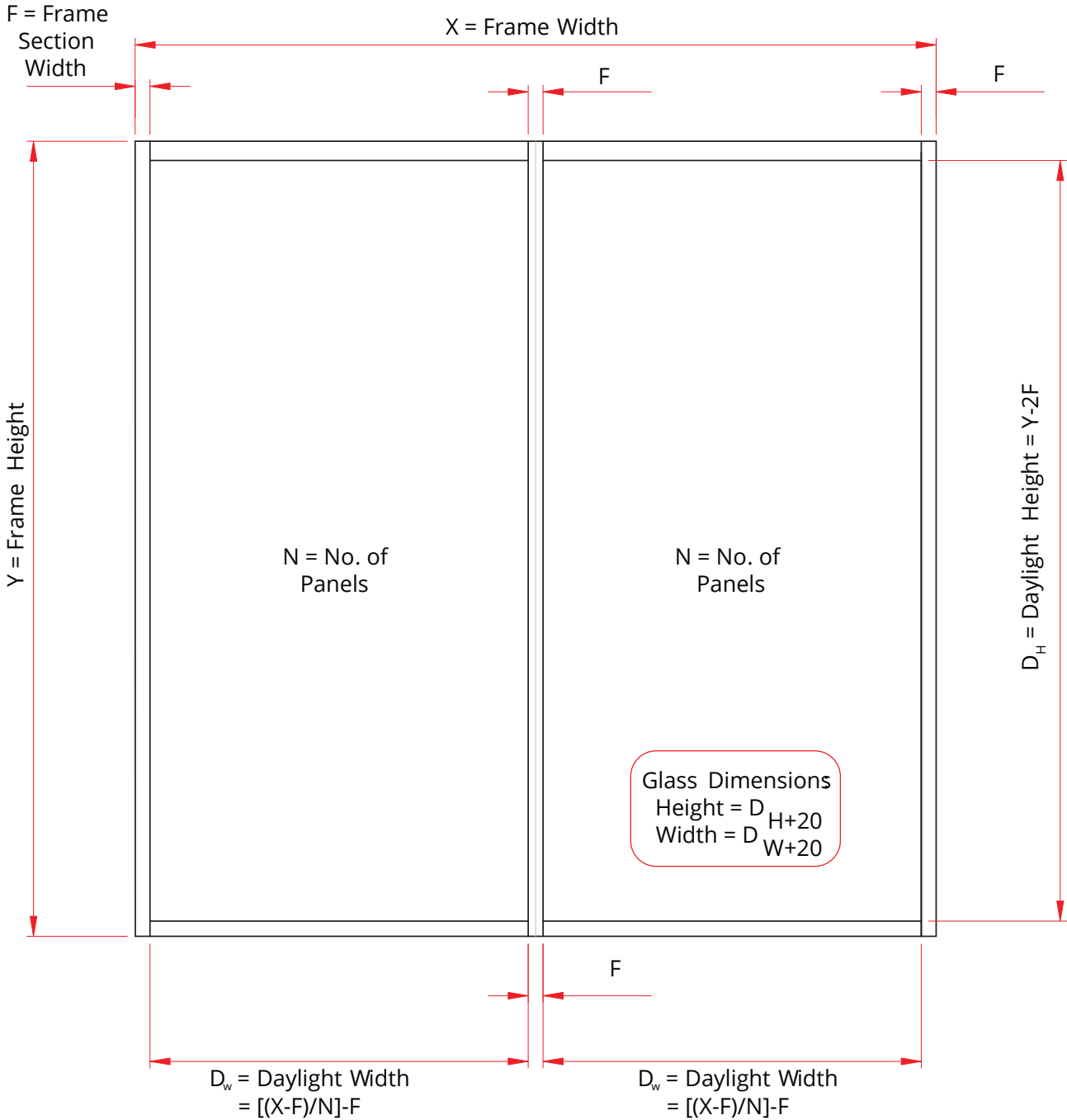

Copyright and important information on page 3

Exploded Assembly Overview

All raw joints need to be sealed with small joint sealer or foam tab option.

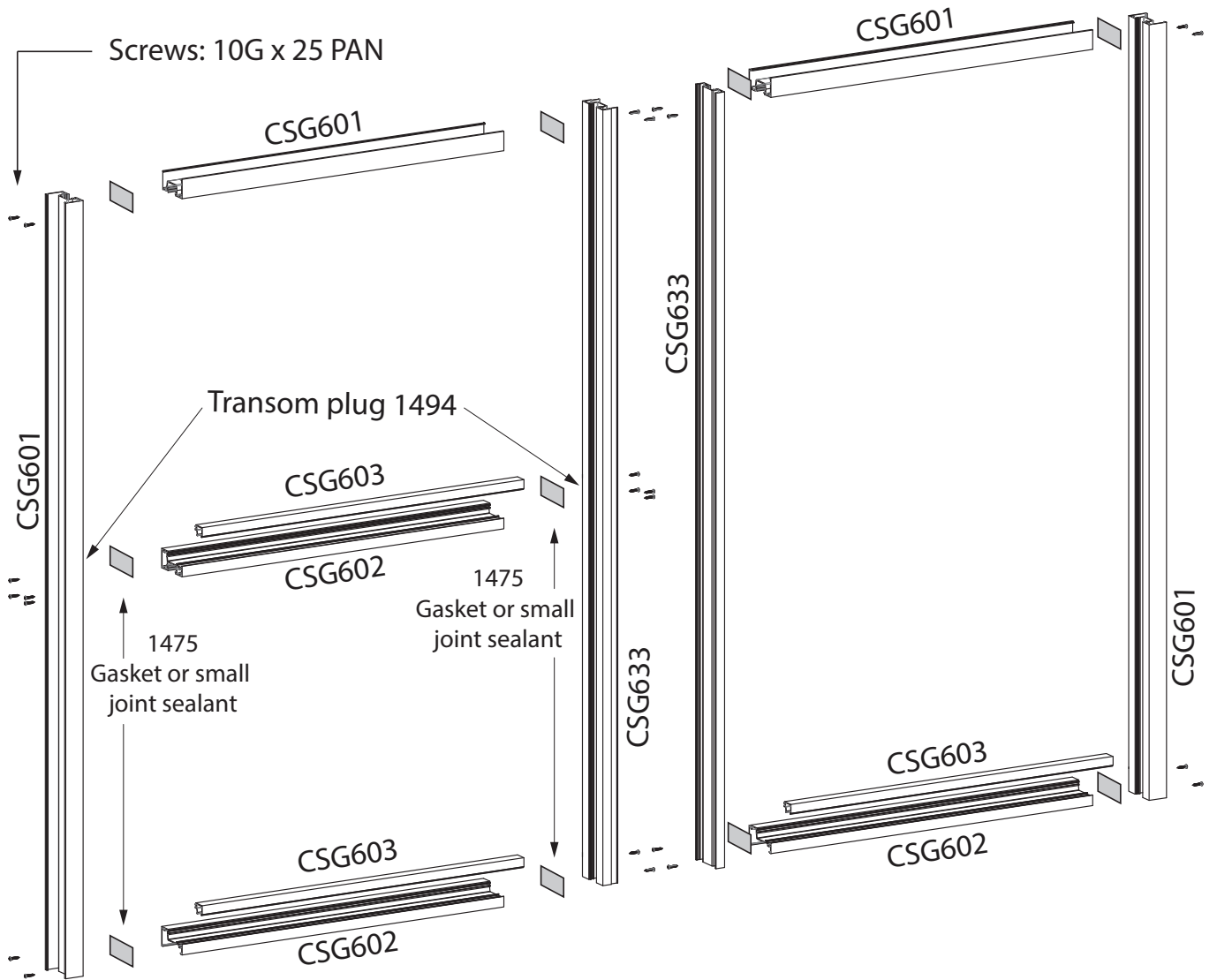

Fabrication

Copyright and important information on page 3

Drainage Details

All raw joints need to be sealed with small joint sealer or foam tab option.

Fabrication

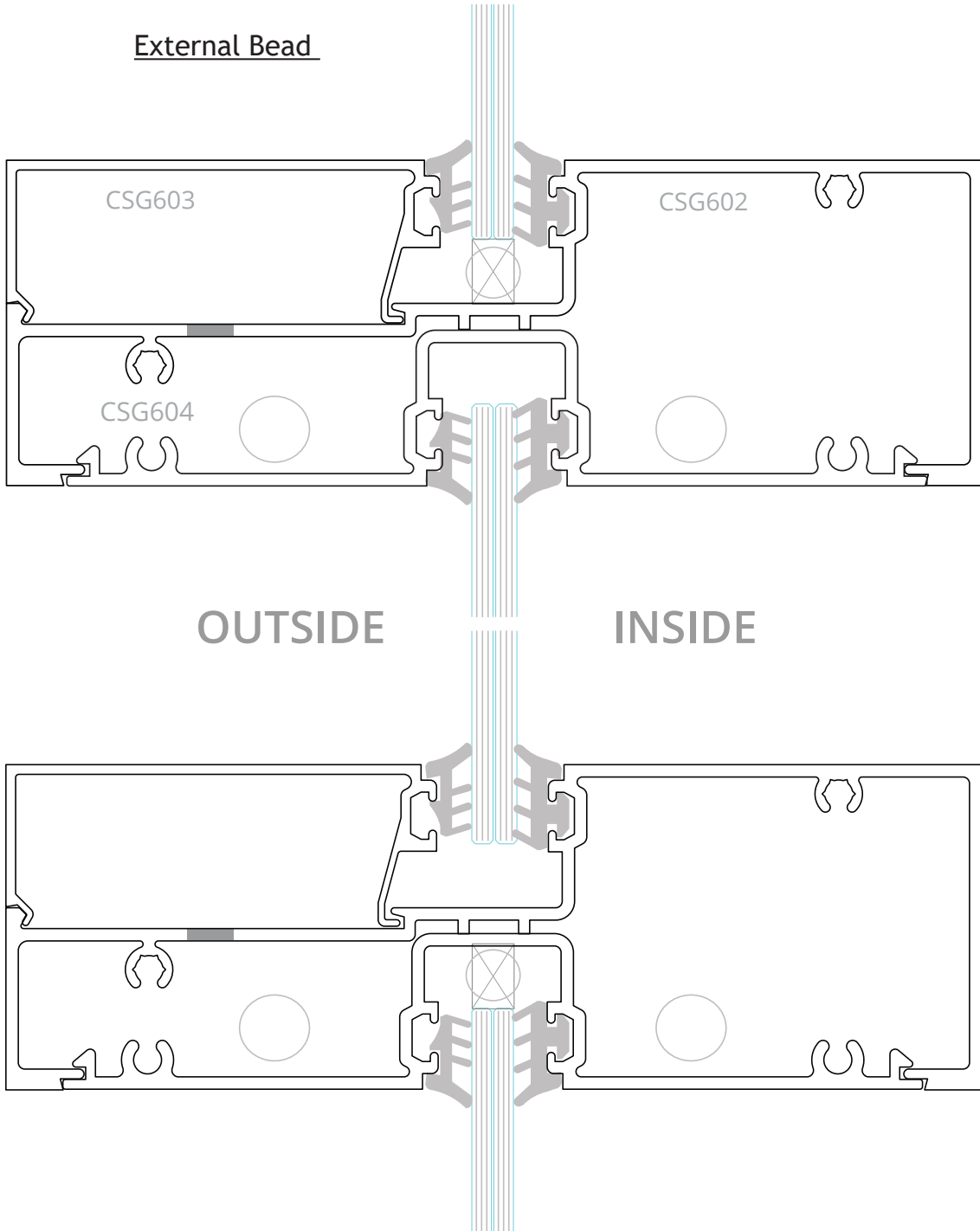

Copyright and important information on page 3

Machining Details: Head

All raw joints need to be sealed with small joint sealer or foam tab option.

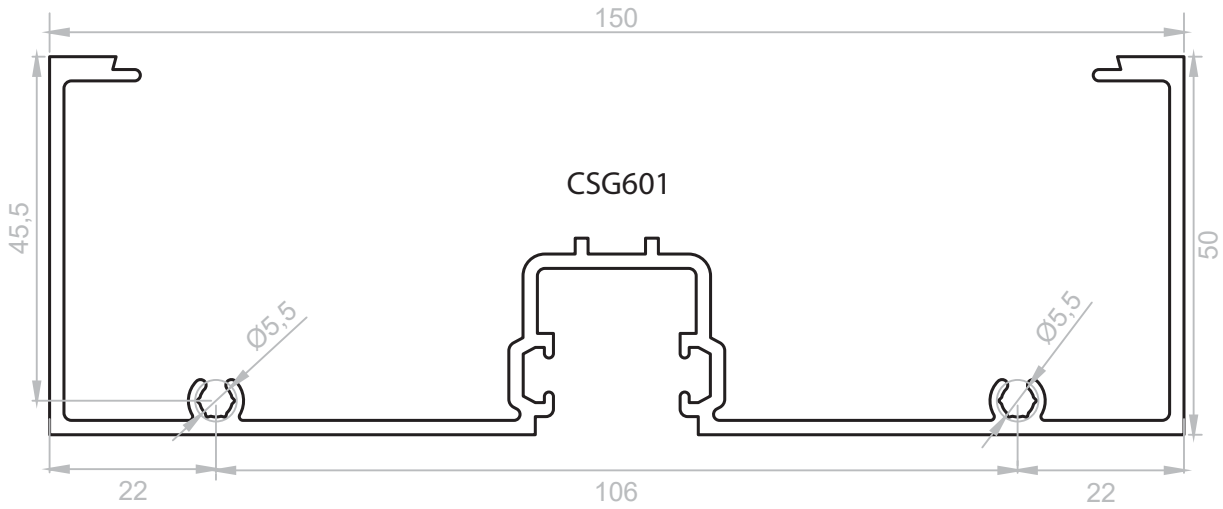

Machining Details: Transom

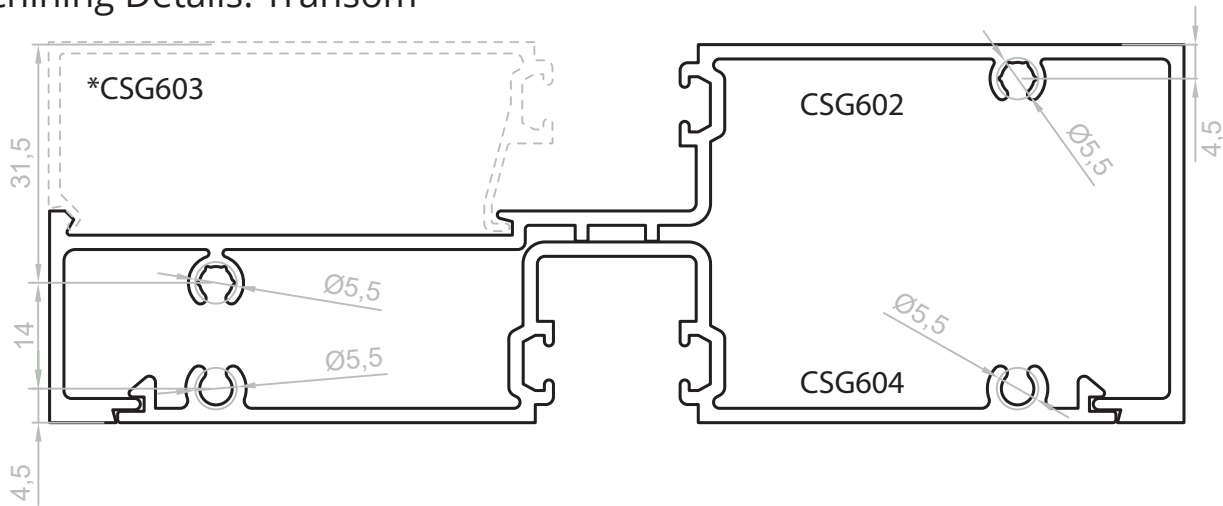

Machining Details: Sill

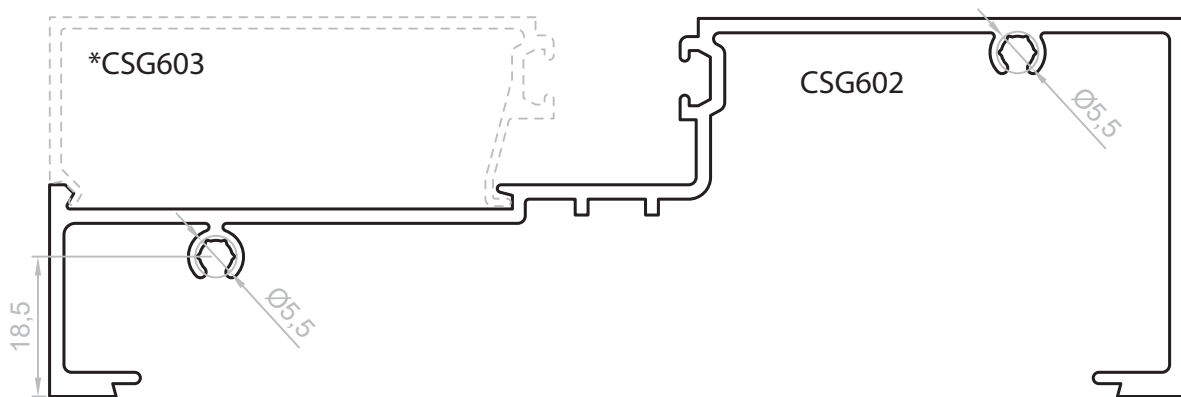

Copyright and important information on page 3

150mm Subhead Options

All raw joints need to be sealed with small joint sealer or foam tab option.

Fabrication

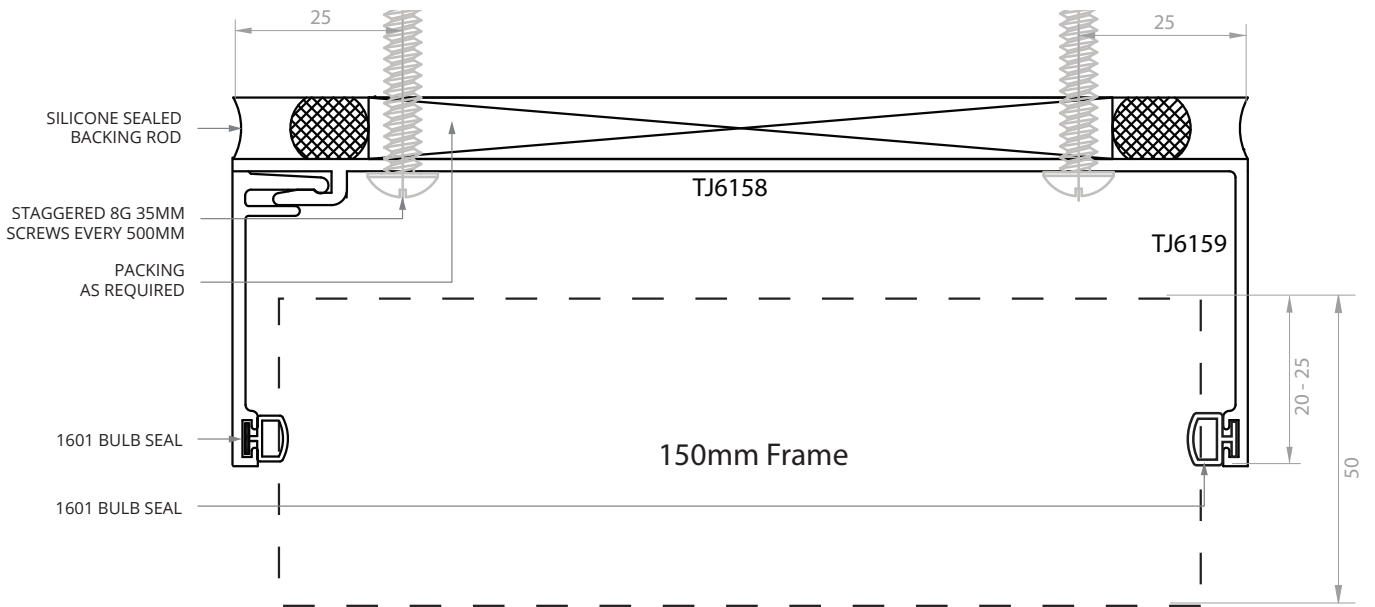
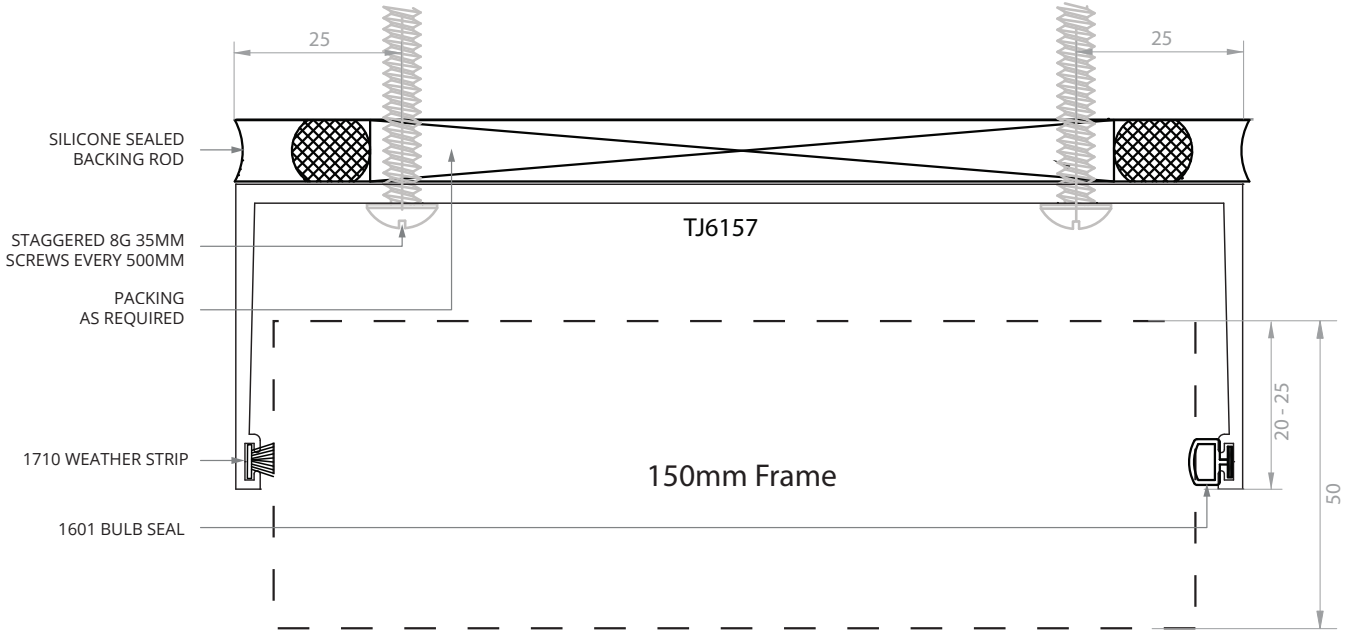

Copyright and important information on page 3

150mm SubJamb Options

All raw joints need to be sealed with small joint sealer or foam tab option.

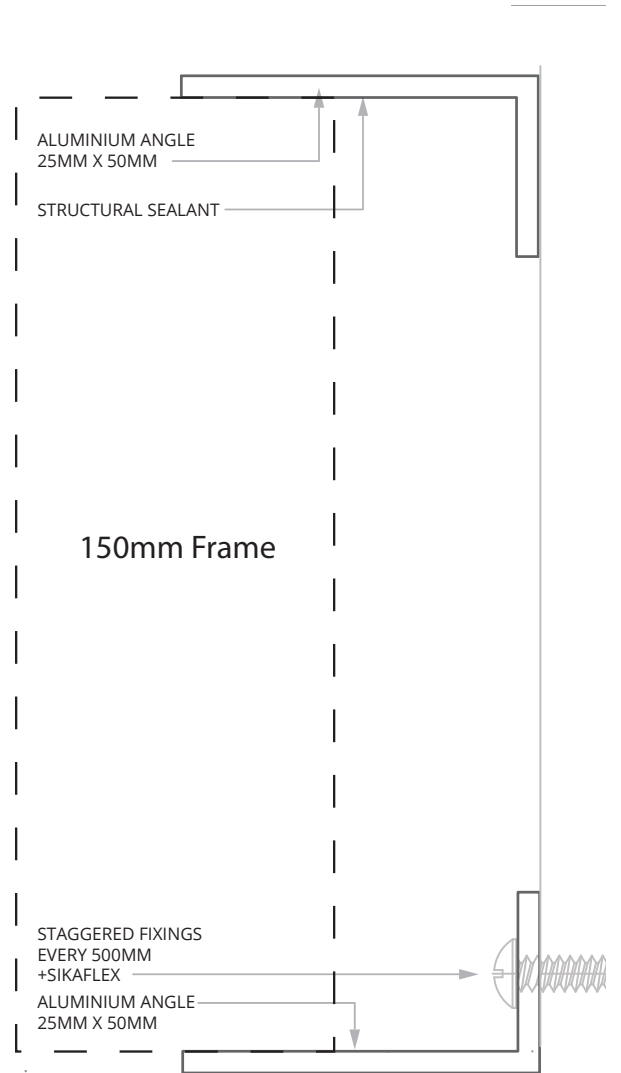
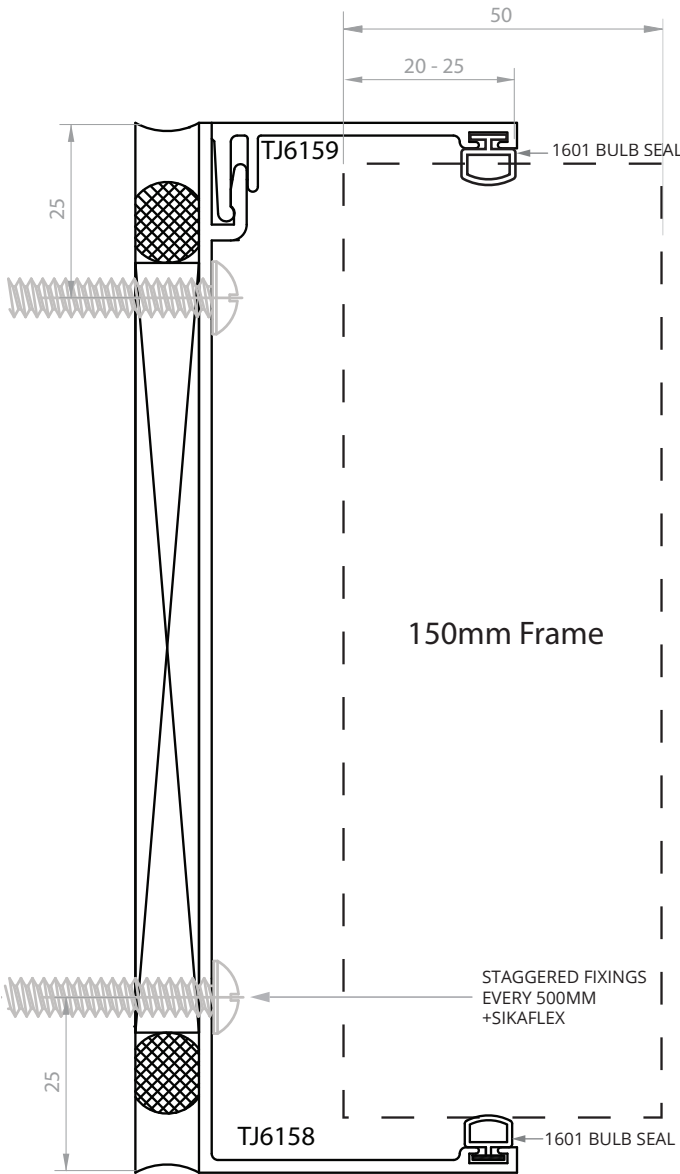

Fabrication

Copyright and important information on page 3

150mm Subframe Internal Bead

All raw joints need to be sealed with small joint sealer or foam tab option.

Fabrication

MACHINED (INTERNAL BEAD)

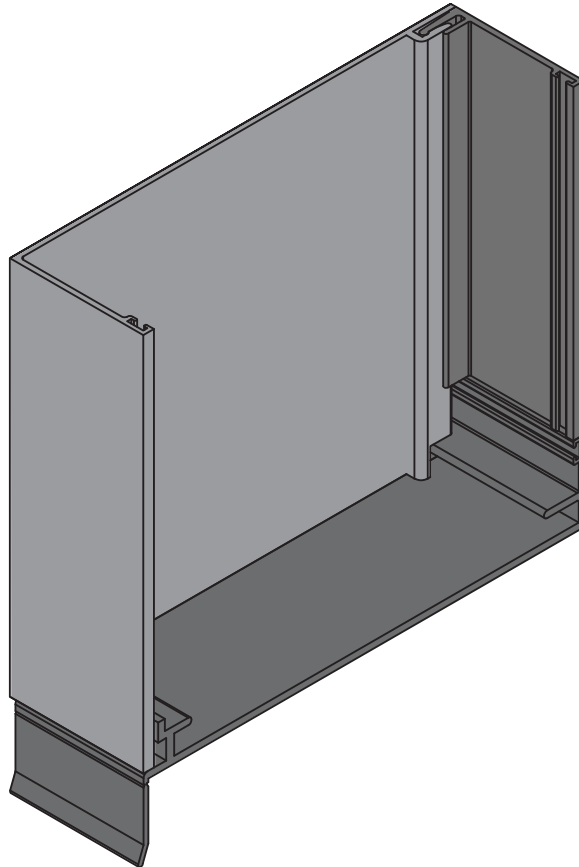
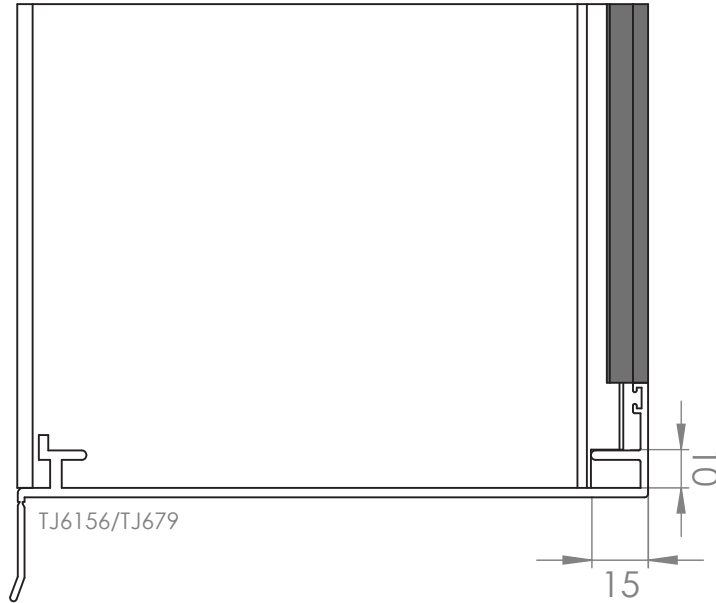

Copyright and important information on page 3

150mm Subframe External Bead

All raw joints need to be sealed with small joint sealer or foam tab option.

SQUARE CUT (EXTERNAL BEAD)

MACHINED (EXTERNAL BEAD)

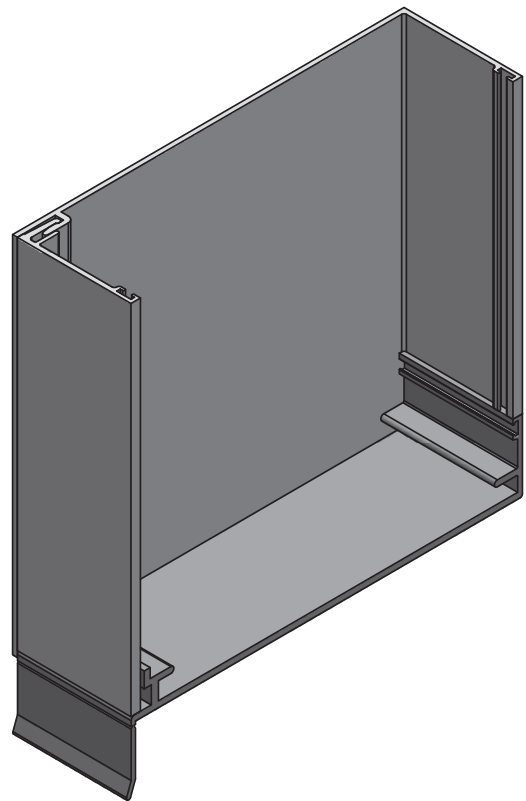
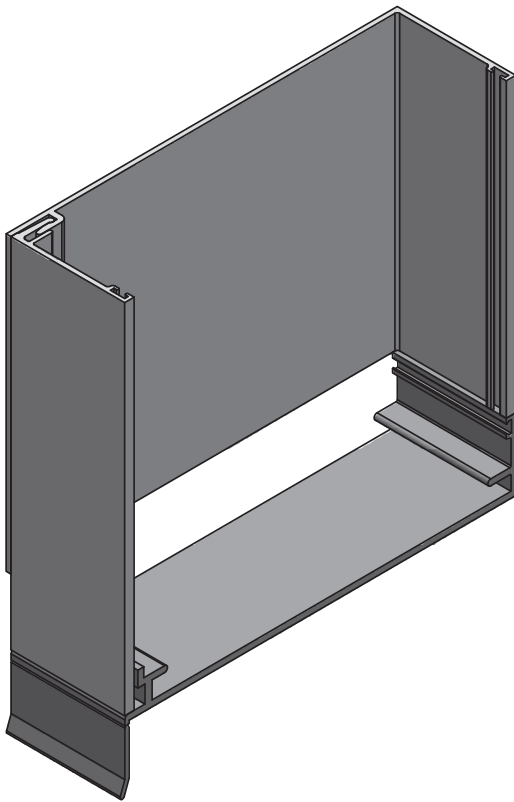
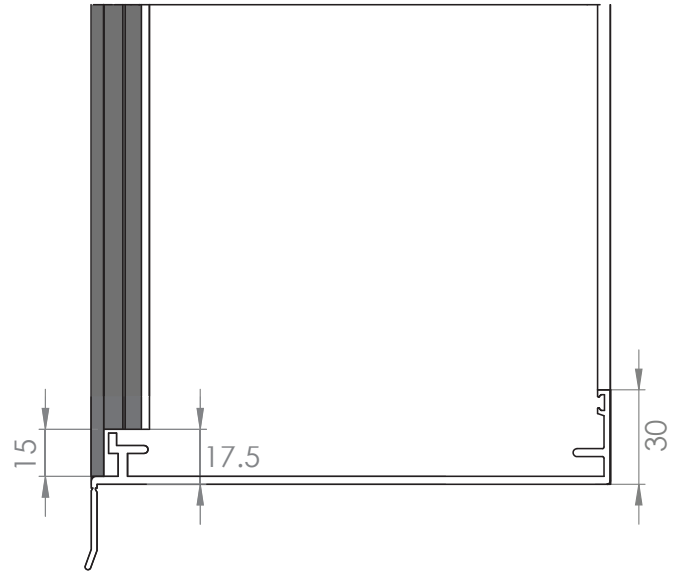
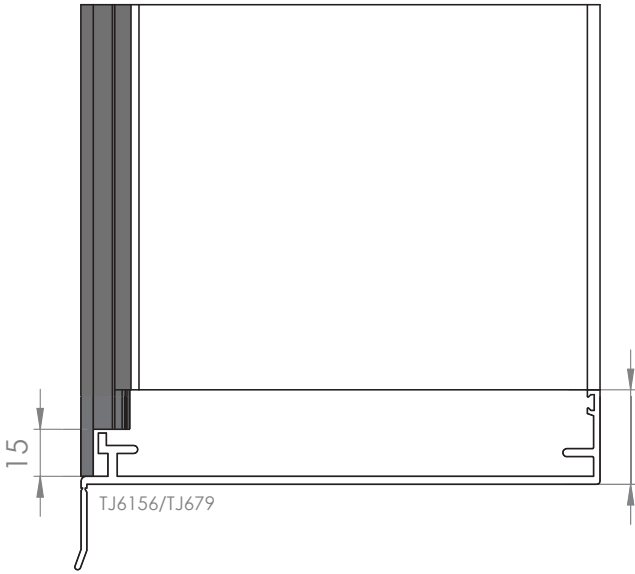

Fabrication

Copyright and important information on page 3

Subsill End-Dam Installation

All raw joints need to be sealed with small joint sealer or foam tab option.

Fabrication

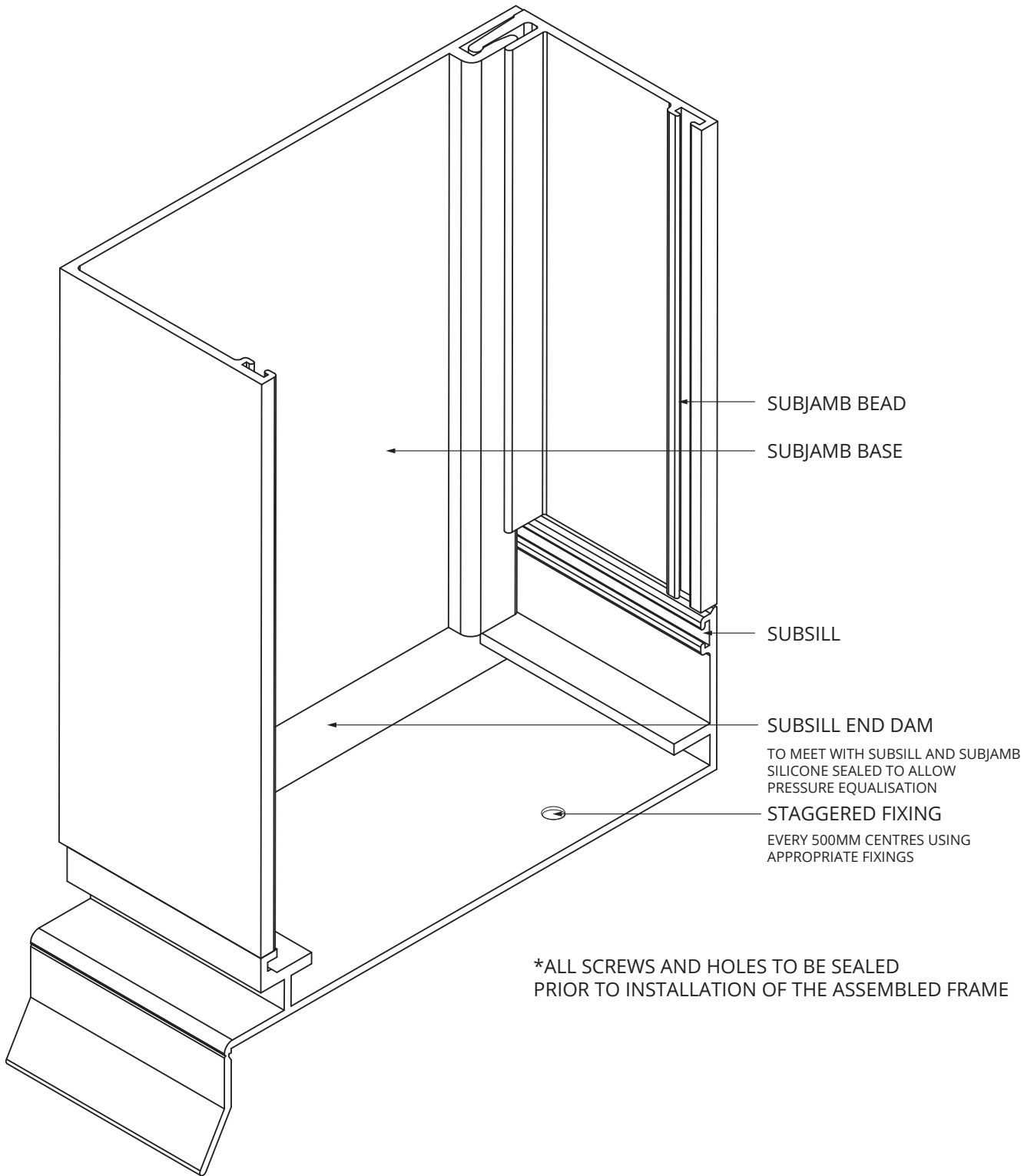

Copyright and important information on page 3

All raw joints need to be sealed with small joint sealer or foam tab option.

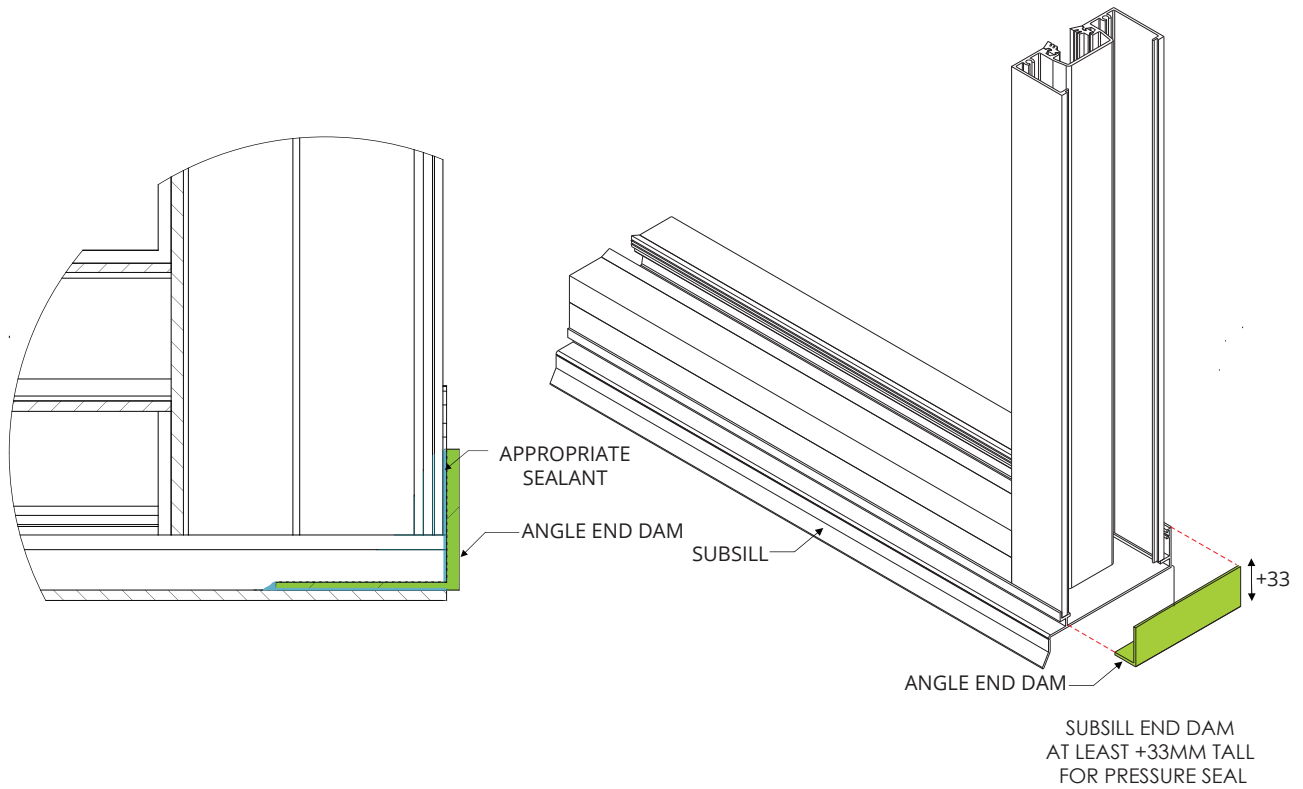
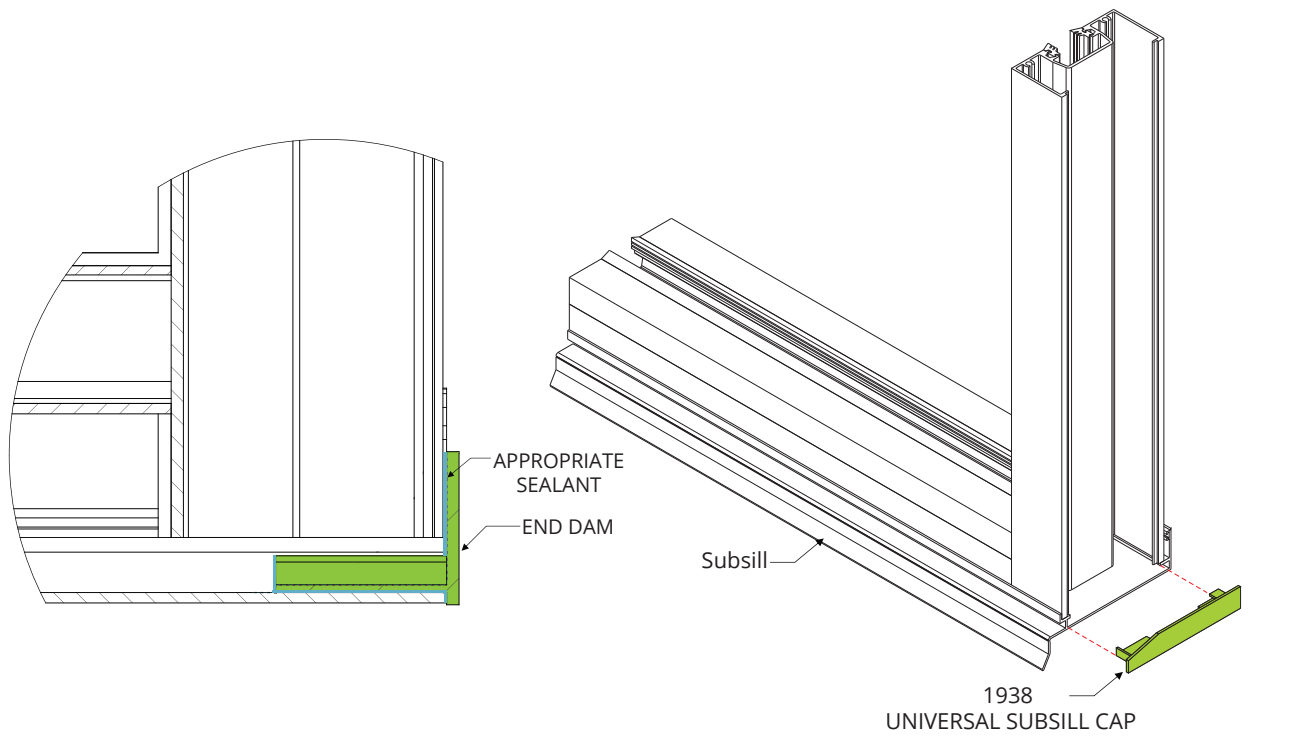

Fabrication

Copyright and important information on page 3

150mm Sump Sill

Fabrication

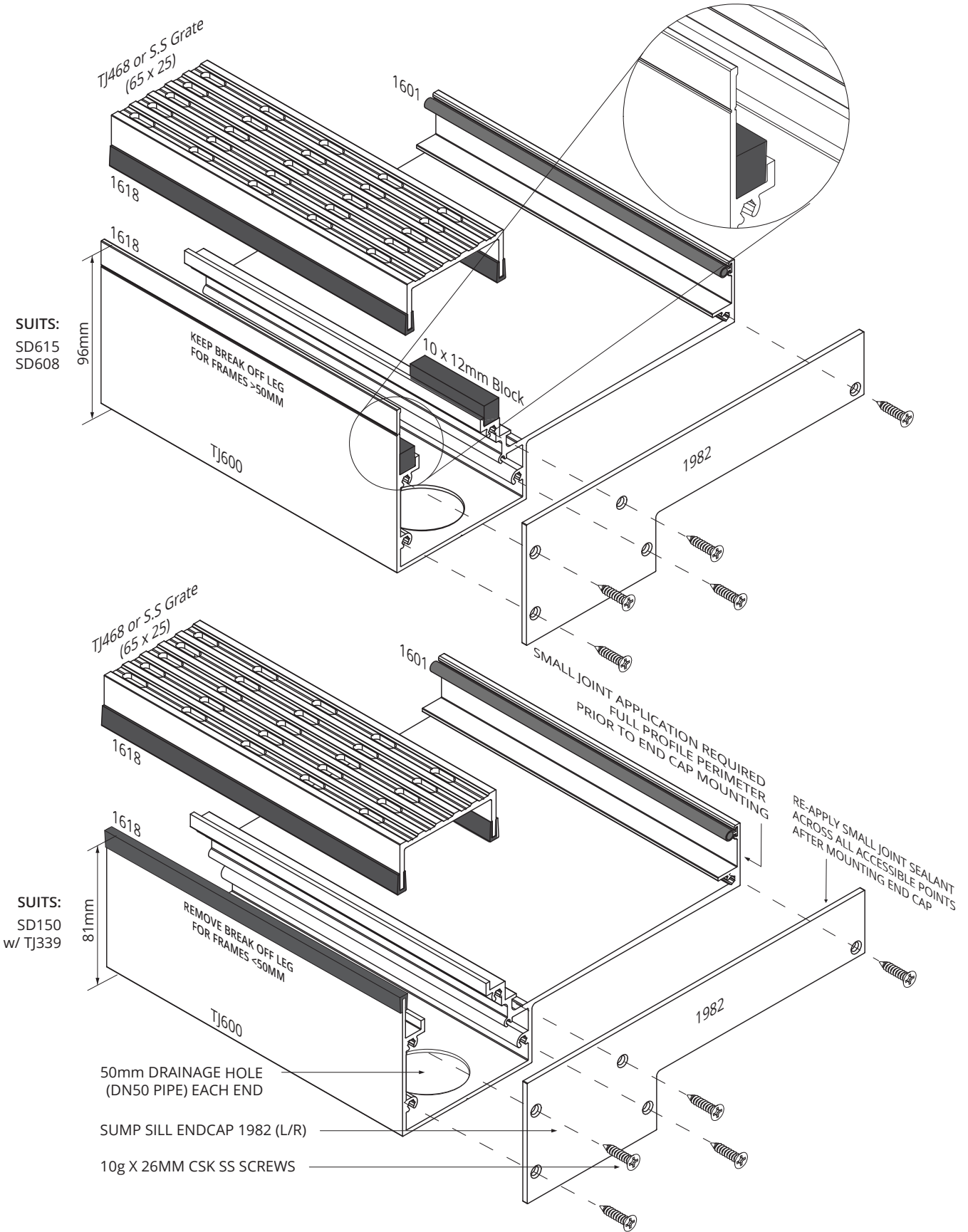

TJ600 Slab Recess Details (1:1)

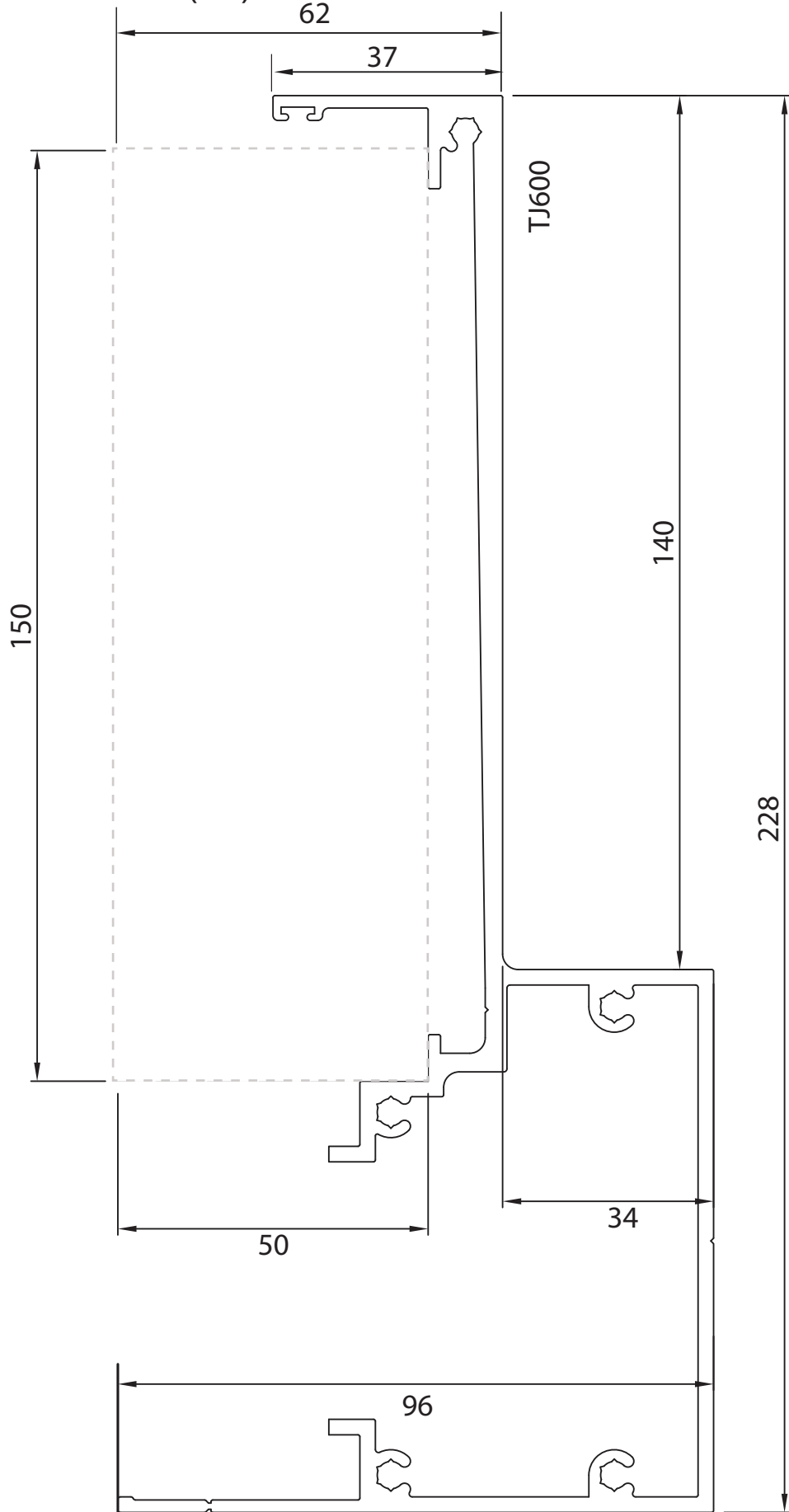

Fabrication

Tooling

BDX-CV-CSG/H/AW

CSG Frame / Hinged / Hook Awning

CSG301	100mm Standard Main Frame
CSG303	CSG Bead
CSG303B	CSG Sloped Bead
CSG304	Glazing Adaptor
CSG320	Standard Duty Self Mating Mullion
CSG333	Heavy Duty Self Mating Mullion
CSG360	100mm Centre Glazed Slim Frame
CSG362	CSG Transom/Sill
CSG390	100mm Light Duty Frame
CSG601	150mm Standard Main Frame
CSG603	CSG Bead
CSG604	Glazing Adaptor
CSG633	Self Mating Mullion
CDG4301	100mm Centre Double Glazed Main Frame
CDG4303	Sill Bead
CDG4303M	Sill Sloped bead
CDG4304	Glazing Adaptor
CDG4310	Male Split Mullion
CDG4311	Female Split Mullion
CDG4312	H/D Male Split Mullion
CDG4313	H/D Female Split Mullion
CDG4314	Male Light Split Mullion
CDG4315	Female Light Split Mullion
CDG4390	Transom/Sill
CDG6501	150mm Centre DG Main Frame
CDG6503	Sill Bead
CDG6504	Glazing Adaptor
CDG6510	Male Split Mullion
CDG6511	Female Split Mullion
CDG6512	H/D Male Split Mullion
CDG6513	H/D Female Split Mullion
HV271	Door Stile
HV272	Hinge Stile
HV273	Large Rail
HV275	Large DG Rail
HV277	Small DG Rail

HV289	Small Rail
HV291	DG Stile
HV322	Sliding Door stile
TJ154	114mm Hinge Stile
TJ155	114mm Lock Stile
TJ158	114mm Pivot Stile
TJ159	114mm Sliding Stile
TJ311	Hinge Stile
TJ312	Lock Stile
TJ313	Door Top Rail
TJ315	Door Bottom Rail
TJ322	Sliding Door Stile
TJ327	Meeting Stile
TJ416	73mm Open Pocket Sliding Stile
TJ417	73mm Open Pocket Hinge Stile
TJ418	73mm Open Pocket Lock Stile
TJ419	DG Top Rail
TJ420	DG Bottom Rail
TJ428	114mm Open Pocket Sliding Stile
TJ435	114mm Open Pocket Hinge Stile
TJ436	114mm Open Pocket Lock Stile
TJ437	114mm Open Pocket Plain Stile
TJ440	73mm Open Pocket Lock Stile
TJ441	73mm Open Pocket Hinge Stile
TJ443	73mm Open Pocket Sliding Stile
TJ444	73mm Open Pocket Plain Stile
TJ450	73mm Open Pocket Meeting Stile
TJ451	114mm Open Pocket Lock Stile
TJ452	114mm Open Pocket Hinge Stile
TJ453	114mm Open Pocket Sliding Stile
TJ725	114mm Open Pocket Plain Stile
TJ737	Flyscreen Adaptor/Winder Support
TJ742	Awning Stile/Rail
TJ747	Hook Awning Sash Rail
TJ749	Hook Awning Sash Stop

[BDX-CV-CSG/H/AW tool set information](#)

Weight	900kg
Dimensions	1420 x 1140 x 800mm (H x W x D)
Outrigger	Yes



Tooling Care and Maintenance

All raw joints need to be sealed with small joint sealer or foam tab option.

KlassicView / CityView / ClimateGuard

Tooling Operation Manual

The following guidelines should be observed to ensure safe and efficient use, longevity and quality production.

All users are responsible for the safe operation and maintenance of tools.

- Read the entire Manual before starting machinery. Machinery may cause serious injury if not correctly operated.
- Never leave machine unattended. Turn power off and wait until machine has come to a complete stop before leaving the machine unattended.
- Disconnect main power before servicing machine. Make sure all power switches are in the off position and air disconnected and make sure all moving parts have come to a complete stop.
- Keep machine well-guarded. Do not remove guards and ensure all guards are in place prior to operation.
- Electric pump will shut down to prevent further damage if there is not enough lubricant.

General Maintenance:

- Please keep tooling lubricated. We recommend using kerosene poured into a spray bottle. Lubricate all pins & blades before starting the machine. (PIC 1)
- We also recommend fortnightly cleaning and lubrication of the guide pins and bushes at the front and rear on both decks. (PIC 2)
Note! Do not use silicon based lubricant under any circumstances as this will build up on the cutting edges of the tool and result in shorter operating life and poor quality results.

Operation:

- Check machine over before operating. Check machine for damaged parts, loose bolts, loose connections, keys and wrenches left on the machine and any other conditions that may affect the machines operation. Repair and replace damaged parts.
- Do not use extrusion that are not specified for this machine.
- Do not use burred, heavy coated or bent extrusions or force extrusions into the tool.
Note that manufacturing tolerance on aluminium can vary. Never hit or force extrusions into die guides.
- While operating do not remove guards and always keep hands outside of the guards.
- Empty swarf trays when required to prevent build up obstructing clearance of discarded aluminium.
Periodically, the die and punches will need sharpening. This must be carried out by experienced toolmaker.

All raw joints need to be sealed with small joint sealer or foam tab option.

Exchange or replace die:

- This is only to be carried out by suitability qualified persons:
 1. Switch off the machine and isolate power point. Removing front covers and swarf trays.
 2. Remove top and bottom screws from the die. Carefully take out the old die block.
 3. Reconnect the power and switch on the machine. Turn to INCHING MODE, press foot valve to ensure the machine desk is on lowest level.
 4. Placing the new block and pins units inside and fixed back into their original positions, then release the inching mode back to operation mode.

Ordering procedure for Replacement or spare parts:

- Please provide following details to your sales representative
 - Machine serial number:
 - Port (DIE) location:
 - List of extrusion involved:
 - Take photo of the issues:

1. (PIC 1) Lubricate all dark grey areas fortnightly with kerosene

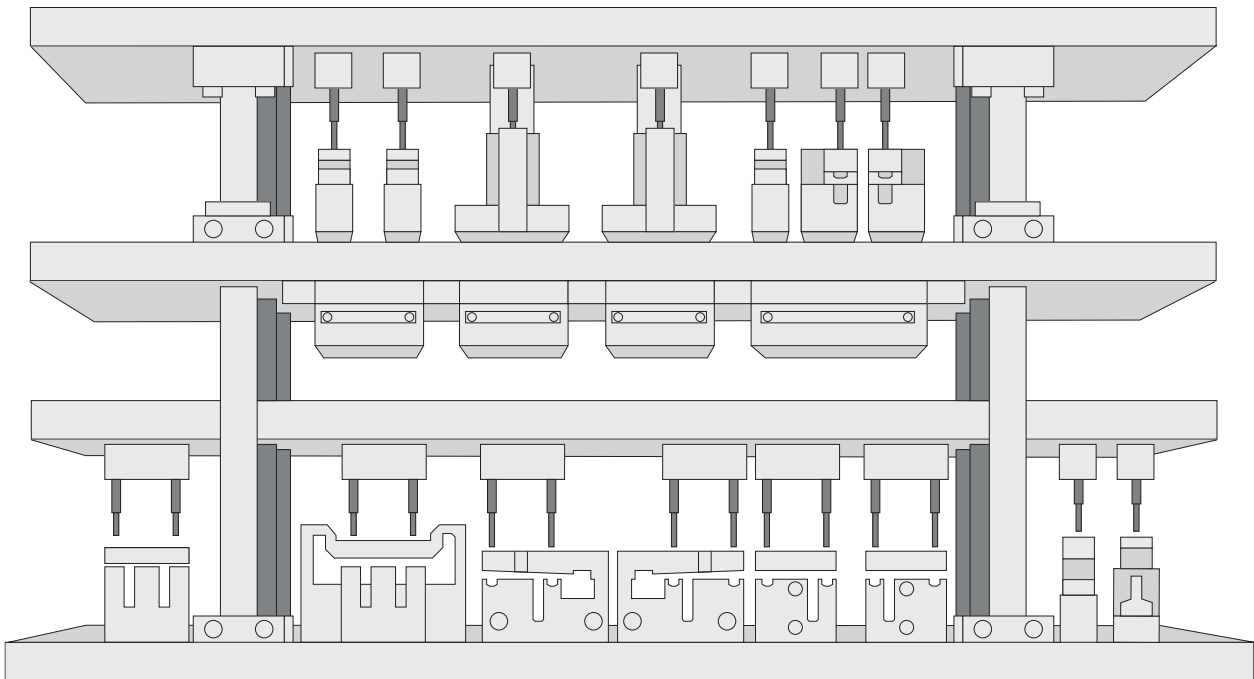

Copyright and important information on page 3

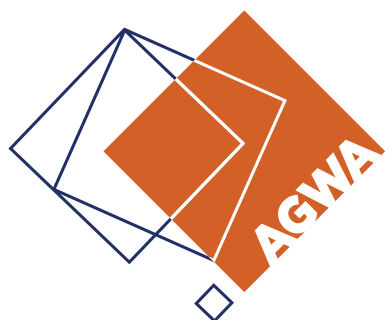

AUSTRALIAN
**GLASS &
WINDOW**
ASSOCIATION
MEMBER



Darley Aluminium

Darley Aluminium are long standing members of various industry associations including the Australian Glass & Window Association (AGWA) and the Window Energy Rating Scheme (WERS) and as such we conform to an Industry Code of Conduct designed to protect consumers.

Manufacturing Standards;

All aluminium extrusions supplied to by Darley Aluminium have been supplied in accordance with Australian Standard AS1866 - 'Aluminium and Aluminium alloy: Extruded rod, bar, solid and hollow shapes'. All Anodised and Painted Extrusions are as per AS1231 Aluminium and Aluminium Alloys - 'Anodic Oxidation Coatings' and AS3715 - 'Metal Finishing-Thermoset Powder Coatings for Architectural Applications of Aluminium and Aluminium Alloys'.

Product Testing and Compliance;

Darley Aluminium products are tested in NATA accredited independent laboratories to ensure they meet the relevant Australian Standards. Energy ratings can also be found on the Window Energy Rating Scheme (WERS) website: <https://agwa.imiscloud.com/WERS/>

[DARLEYALUMINIUM.COM.AU](https://www.darleyaluminium.com.au)

ABN 14 076 364 657

NEW SOUTH WALES

8 Tyrone Place, Erskine Park NSW 2759
Tel: (02) 8887 2888
Fax: (02) 9834 3244
salesnsw@darleyaluminium.com.au

VICTORIA | SOUTH AUSTRALIA

10 Bridge Road, Keysborough VIC 3173
Tel: (03) 9238 3888
Fax: (03) 9768 7288
salesvic@darleyaluminium.com.au

WESTERN AUSTRALIA

36 Armstrong Road, Hope Valley WA 6165
Tel: (08) 9437 2999
Fax: (08) 9437 1024
saleswa@darleyaluminium.com.au

QUEENSLAND

29 Access Avenue, Yatala QLD 4207
Tel: (07) 3287 1888
Fax: (07) 3287 2088
saleqld@darleyaluminium.com.au



Warranty

Darley Aluminium, Door & Framing extrusions are warranted for a period of 6 years as per AS2047 requirements, unless otherwise specified. Powder coat and anodised finished can be warranted for extended periods subject to application. Warranty is subject to the following conditions:

- The product is installed in accordance with the relevant Building Codes practices and maintained as per the recommended Care & Maintenance.
- The product has not been subject to misuse, physical abuse or neglect.
- Claims under this warranty should be made within one month of defect arising in the product.
- A documented maintenance schedule is required to obtain extended warranty.

Care & Maintenance

- A gentle wash with a soft non-abrasive brush or cloth using a mild detergent followed by a fresh water rinse will maintain the long term performance of the powder coat or anodised finish.
- If paint splashes, sealants or other residue need to be removed, then methylated spirits or white spirits can be applied with a soft cloth and gentle wiping only.
- In rural or normal urban environments, cleaning should occur at least every 12 months.
- In areas of pollution, industrial or coastal areas back one kilometre from the water, cleaning should occur at least every 3 months.
- In hazardous locations such as beachfronts, severe marine environments or areas of high industrial pollution, the frequency of cleaning should be increased to monthly.
- Special maintenance may be required in some extended warranty applications.

Tracks Keep tracks free from obstruction and excessive dirt or water.

Guides and Spindles To be greased with good quality automotive grease every 6 months.

Rollers As per manufacturer's instructions.

Hinges, Hangers & Flush Bolts Visible surfaces should be cleaned using a damp cloth and mild detergent, then wiped dry. Apply a light application of non-corrosive preventative lubricant to all surfaces and internals, using a dry cloth to remove excess. Repeat at intervals no greater than 3 months.

Seals and PVC Product An occasional wipe with a damp cloth or a wash with warm soapy water is all that is required.

Glass Simply wipe over the surface with a few drops of methylated spirits on a damp cloth, then polish the surface with a dry, lint-free, non-abrasive cloth.

Ver 3: August 2023

DARLEYALUMINIUM.COM.AU

ABN 14 076 364 657

NEW SOUTH WALES

8 Tyrone Place, Erskine Park NSW 2759
Tel: (02) 8887 2888
Fax: (02) 9834 3244
salesnsw@darleyaluminium.com.au

VICTORIA | SOUTH AUSTRALIA

10 Bridge Road, Keysborough VIC 3173
Tel: (03) 9238 3888
Fax: (03) 9768 7288
salesvic@darleyaluminium.com.au

WESTERN AUSTRALIA

36 Armstrong Road, Hope Valley WA 6165
Tel: (08) 9437 2999
Fax: (08) 9437 1024
saleswa@darleyaluminium.com.au

QUEENSLAND

29 Access Avenue, Yatala QLD 4207
Tel: (07) 3287 1888
Fax: (07) 3287 2088
saleqld@darleyaluminium.com.au

Darley Aluminium delivers complete, high-performance aluminium window, door and framing solutions for residential, commercial or architectural projects – combining Australian design, reliable supply, and expert support to make every project easier.

Window, Door and Framing



High-performance commercial window, door and framing systems designed for flexibility, durability, and seamless integration into modern architectural projects.



Modern, versatile window and door systems that bring style, flexibility, and reliable performance to any home.



Premium multi-fold door systems that deliver expansive openings, smooth operation, and architectural sophistication for high-end spaces.



Energy-efficient window and door systems designed to keep interiors comfortable while reducing heat transfer.

Security



Advanced heavy-duty security screens that provide maximum protection without compromising visibility, airflow, or style.



Durable, corrosion-resistant aluminium screening that combines security, strength, and design versatility for any application.

Outdoor Screening and Enclosure



Durable, all-weather enclosures that let you enjoy open-air living with protection from insects and the elements.



A sleek, easy-to-install screening solution that enhances privacy and style across any space.

What sets Darley Aluminium apart?

- Complete Solutions – Everything you need from system to support that simplifies specification, fabrication, and installation.
- Australian Designed – Built for local conditions and standards, delivering lasting quality and compliance.
- Proven Reliability – Trusted for over 30 years with a national distribution network delivering consistent supply and dependable service



Darley Aluminium understands how important it is to receive trusted solutions, quality products, and reliable supply. That's why we are committed to delivering high standards and friendly, dependable service you can rely on.

Contact your local Darley Aluminium distributor or fabricator today.

New South Wales Head Office

8 Tyrone Place, Erskine Park NSW 2759
Tel (02) 8887 2888 | Fax (02) 9834 3244
salesnsw@darleyaluminium.com.au

Victoria and South Australia

10 Bridge Road, Keysborough VIC 3173
Tel (03) 9238 3888 | Fax (03) 9768 7288
salesvic@darleyaluminium.com.au

Queensland

29 Access Avenue, Yatala QLD 4207
Tel (07) 3287 1888 | Fax (07) 3287 2088
salesqld@darleyaluminium.com.au

Western Australia

36 Armstrong Road, Hope Valley WA 6165
Tel (08) 9437 2999 | Fax (08) 9437 1024
saleswa@darleyaluminium.com.au

Your local fabricator

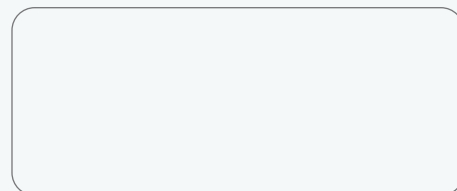

darleyaluminium.com.au

Proud members of

