

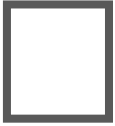

# Extreme Security System

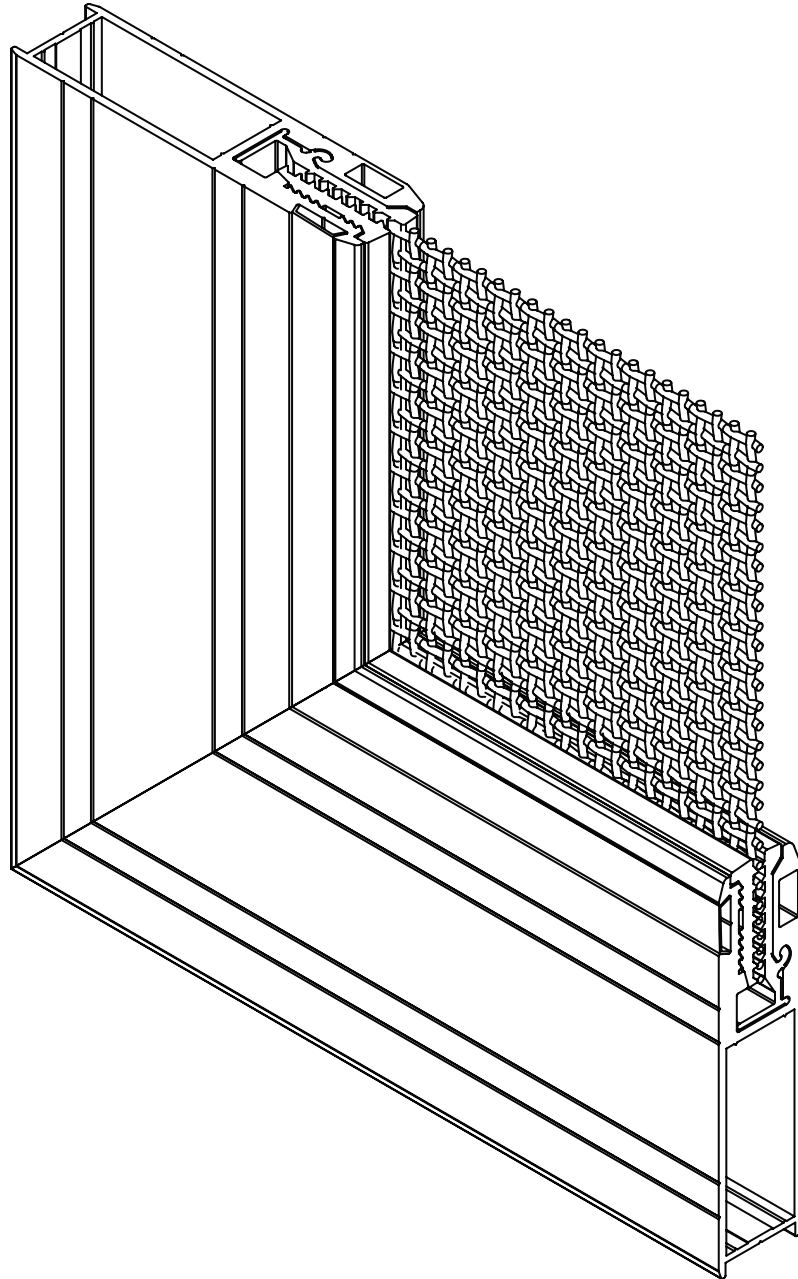

Aperture - 1.98 x 1.98  
Open Area - 61%





# Disclaimer

Darley Aluminium strives to ensure the technical details contained in this manual are complete and correct. Occasionally, some errors or outdated information may require rectification - Darley Aluminium takes no responsibility for any loss or damage as a result of these errors. If you are unsure of any information provided within this manual, please contact your nearest Darley Aluminium office.

Engineering, manufacture and installation of frames must meet requirements of AS2047 (Windows in Buildings).

Glazing selected must meet requirements of AS 1288 (Glass in Buildings).

Size limitations are governed by design intent, glass selection, and local wind load requirements as per AS/NZS 1170.2 (Wind Actions) or AS 4055 (Wind Loads for Housing). An Engineer should be consulted to ensure selected framing and installation meets the requirements as set out by the relevant Australian Standards.

Any reference to an Australian Standard within this manual is based on the interpretations of Darley Aluminium. Code Compliance responsibility remains with the user of this manual. Misuse or misinterpretation of the information in this manual or of the Australian Standards remains the responsibility of the user of this manual.

# Copyright

This technical manual and the information within remains the property of Darley Aluminium. The manual must not be reproduced, copied or loaned without prior agreements with Darley Aluminium.

# Contents

## Introduction 5

<b>Welcome.....</b>	<b>5</b>
Security Frames.....	6
Sliding FlyDoor Frame Profiles .....	7
Plant on Sliding FlyDoor Frame Profiles .....	8
Interlock Profiles .....	9
Hinged Security Door Frame Profiles	10
Additional Profiles.....	12
Screenfold Profiles/ Hardware .....	13
Tools and Equipment.....	14
Hinged Door Hardware .....	16
Sliding Door Hardware .....	17
Cylinders and Misc Hardware.....	18

## Performance 19

<b>Test Results.....</b>	<b>19</b>
Security Test Report: Fixed Window ..	20
Security Test Report: Hinged Door.....	20
Security Test Report: Fixed Window ..	21
Security Test Report: Fixed Window ..	22
Security Test Report: Hinged Door.....	22
Security Test Report: Fixed Window ..	23
Security Test Report: Hinged Door.....	23
Security Test Report: Hinged .....	24
Security Test Report: Hinged Door.....	24
Security Test Report: Sliding Door .....	25
Rail Pre-Loading (Mesh Bow Reduction) .....	27
Assembly .....	28
Sliding Door Head and Sill Options....	32

## Fabrication 32

<b>General Configuration.....</b>	<b>32</b>
Sliding Door Jamb Options.....	33
Sliding Door Interlock Options .....	34
Hinged Door Options.....	35
Austral Elegance (2156) / Austral Forge (4300).....	38
Austral Ultimate (2131) / Austral Forge (4100).....	39
Lockwood 8654 Hinged Door Lock (2105).....	40

Yale Quattro Hinged/Sliding Door Lock (2103 / 2154).....	41
Lockwod 8653 Sliding Door Lock (2155) .....	42
Austral SD7 Sliding Door Lock (2151)	43
Barrier Multifolding Doors .....	44
2914 Tool Setup Details.....	50
2914 Window Corner Crimper Details .....	52
2916 Corner Stake Punch .....	53
2910 Security Door Lock and Wheel Punch.....	54
2915 Security Door Lock Site Tool.....	55

## Appendix 63

Release Notes .....	63
---------------------	----

# Welcome

## Overview

ScreenGuard Extreme™ security screens and doors are designed, engineered and tested for strength, durability, and quality. Built with high-tensile 304 marine-grade stainless steel mesh, they provide superior protection and resilience. The unique aluminium frames are tempered to T6, ensuring maximum strength and durability. To enhance durability, the stainless steel wire mesh is coated with a specialised UV protective finish, offering a clear, long-lasting appearance. ScreenGuard™'s patented security system meets and exceeds the rigorous Australian Standard AS 5039-2023, making it a trusted choice for security and peace of mind.

## Design Features

- No expensive machinery to manufacture
- Easy to fabricate, saves you cost on time and labour
- Use of 304 Grade Stainless Steel Security Mesh, low maintenance
- Competitive prices
- Both nylon and metal corner stakes tested

## Technical Specification

Frame Type	6063 - T6 (Alloy Frame Temper)
Mesh Type	304 Grade Stainless Steel High-Tensile Woven Security Mesh
Wire Diameter	1.2 mm (2.4mm overall sheet thickness)
Mesh Count	8 x 8 strands per square inch
Aperture Size	1.98 mm x 1.98 mm (excluding coating)
Open Area	61% (excluding coating)
Tensile Strength	740mpa +/- 2%
Unit Weight per m <sup>2</sup>	5.6kg +/- 2%
Surface Finish	Powdercoated Black
Knife Shear Test	3 Cuts under 350N Passed
Salt Spray Test	Passed 1300hrs

## Performance Summary

AS1170



AS5039:2023



Security Frames

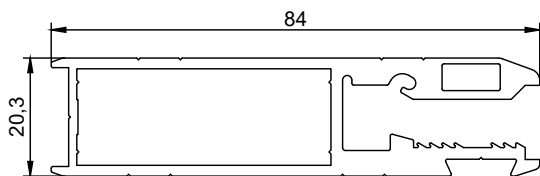

**AU01012**  
Security Extreme Door Frame

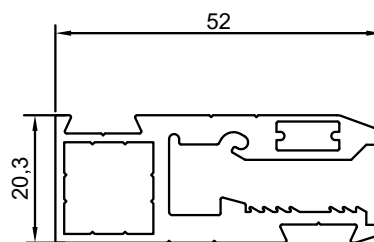

**AU01015**  
Security Extreme Window Frame

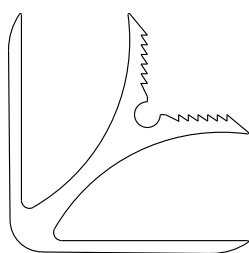

**2655**  
Corner Stake (7.4mm)  
To suit AU01001

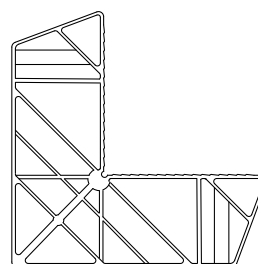

**2659**  
Nylon Corner Stake

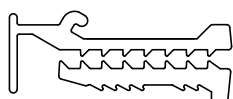

**2541**  
PVC 2-Part Wedge / Seat

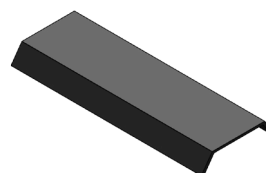

**1675**  
Cover Strip

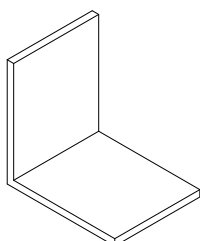

**1861**  
Corner Stake  
to Suit AU01016

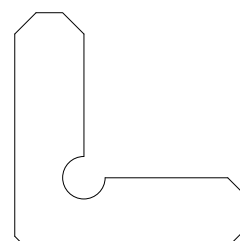

**2679**  
Corner Stake  
To Suit AU01015

Sliding FlyDoor Frame Profiles

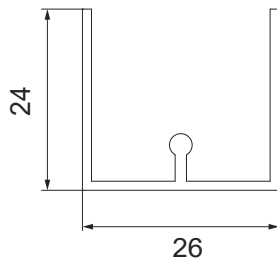

**DT3221**  
Top & Bottom  
Sliding Track

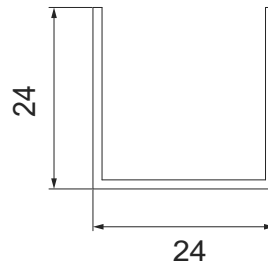

**DT3223**  
U Channel  
24 x 24 x 1.2mm

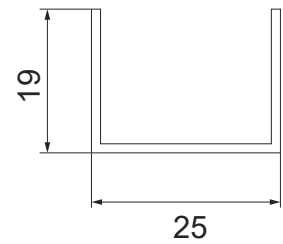

**DT3192**  
U Channel  
19 x 24 x 1.2mm

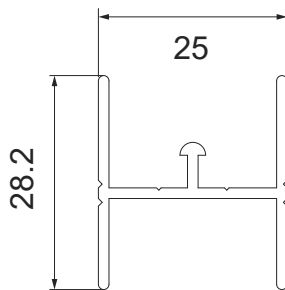

**DT3333**  
Door Single Track

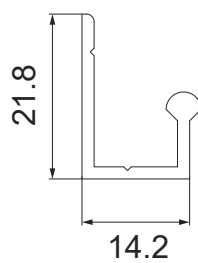

**DT3231**  
J Track

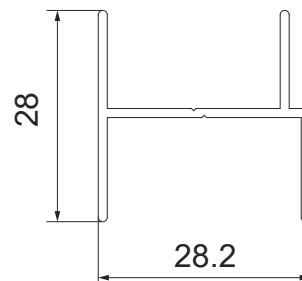

**DT3344**  
Door Jamb /  
Offset Receiver

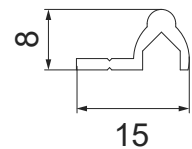

**DT3232**  
PIP Floor Track

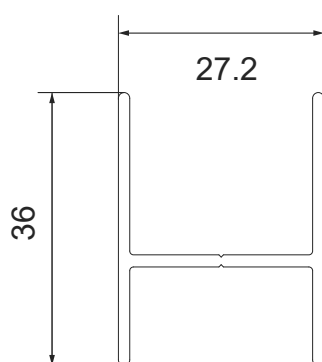

**DT3202**  
Large H

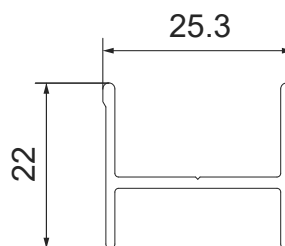

**DT3204**  
H Receiver  
Light Duty

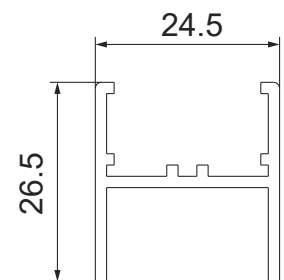

**DT3205**  
H Receiver  
Heavy Duty

Plant on Sliding FlyDoor Frame Profiles

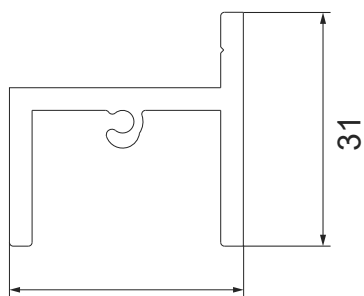

**SD421**  
Single Fly Door Head  
Face Fix

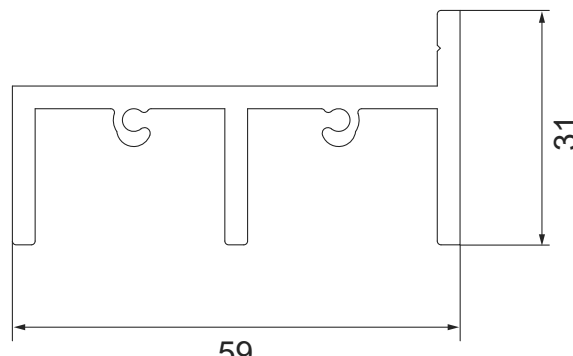

**SD621**  
Double Fly Door Head  
Face Fix

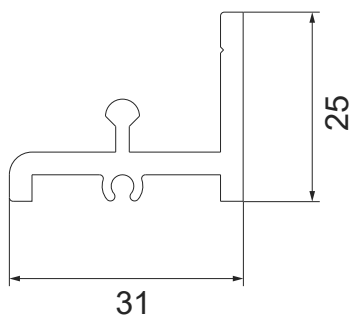

**SD422**  
Single Fly Door Sill  
Face Fix

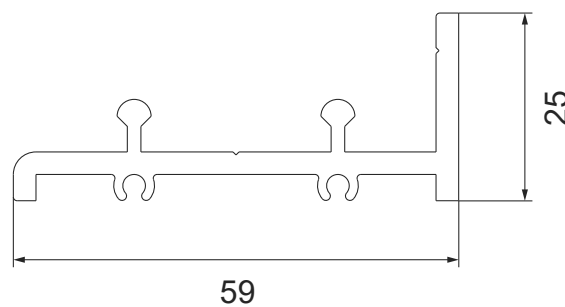

**SD622**  
Double Fly Door Sill Track  
Face Fix

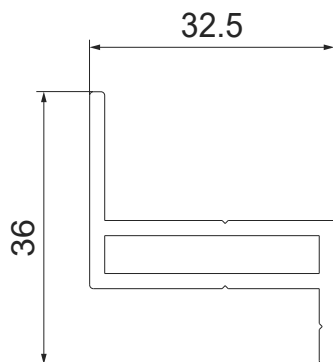

**SD425**  
Single Fly Door Jamb  
Face Fix

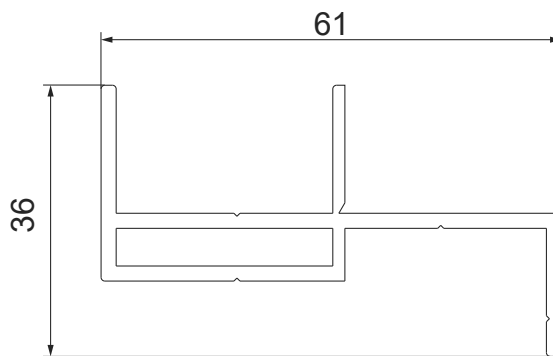

**SD625**  
Double Fly Door Jamb  
Face Fix

Interlock Profiles

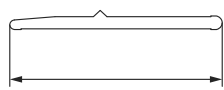

28.2

**DI3228**  
Flat Interlock



45

**DI3214**  
HD 3mm  
Offset Interlock

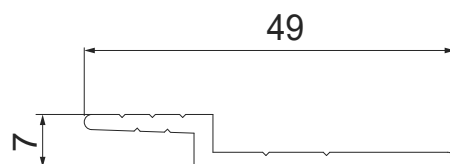

49

**DT3206**  
7mm Offset Interlock  
Extended

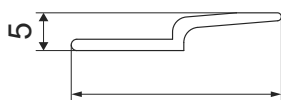

28

**DI3229**  
3mm  
Offset Interlock



45

**DI3215**  
Heavy Duty  
Flat Interlock

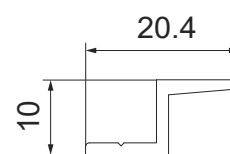

20.4

**SD626**  
10mm Offset Interlock  
For Arch. Door

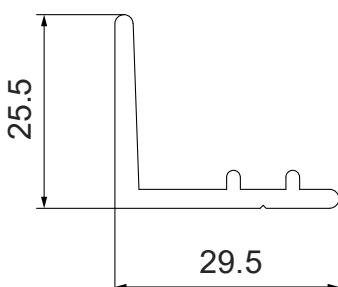

25.5

29.5

**DI3216**  
Heavy Duty  
Frame Interlock

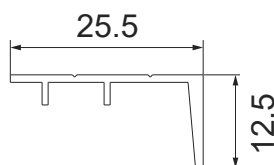

25.5

12.5

**DI3225**  
Frame Interlock  
(Female)

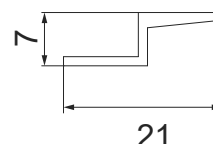

7

21

**DI3224**  
7mm  
Offset Interlock

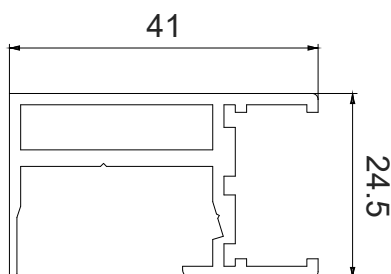

41

24.5

**DT3207**  
Corner Receiver

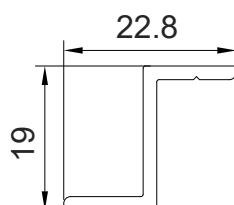

22.8

19

**SD620**  
20mm Offset Interlock  
For Arch. Door

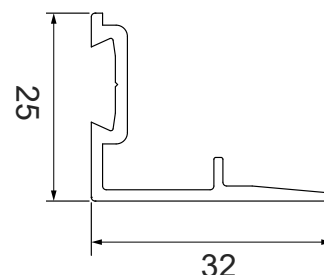

25

32

**SWD037**  
Frame Interlock  
For Patio Door

Hinged Security Door Frame Profiles

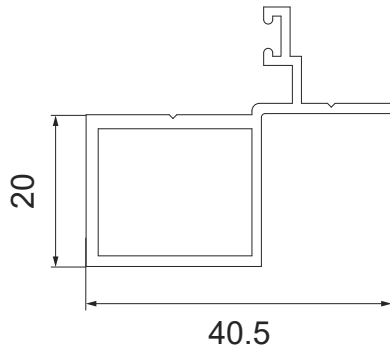

**DJ3250**  
Enclosed Jamb Adaptor Small

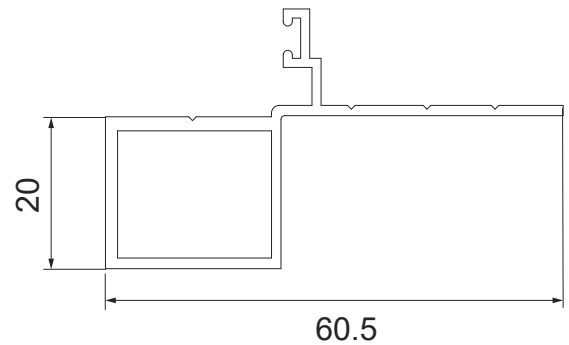

**DJ3260**  
Enclosed Jamb Adaptor

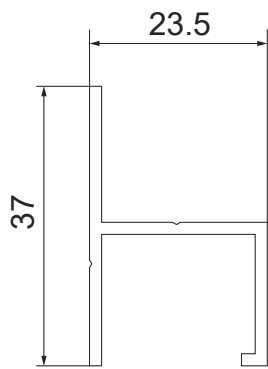

**DT3203**  
Top Track Adaptor

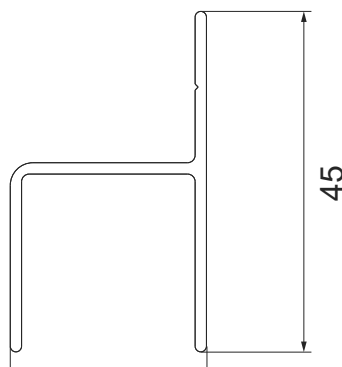

**DT3219**  
Security Top Track

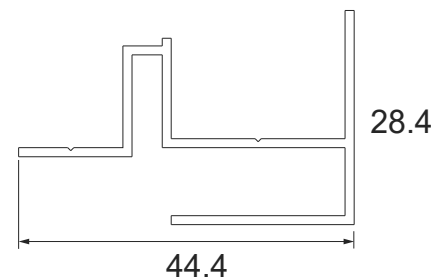

**DJ3271**  
J Jamb Adaptor

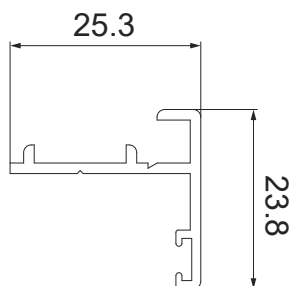

**DT3210**  
T Section Double Door  
w/ seal

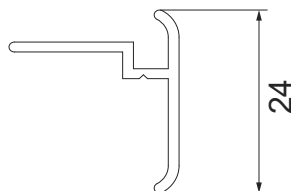

**DT3226**  
Light T Section  
Double Door w/ seal

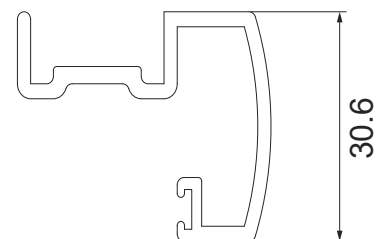

**DT3236**  
Double Door Cover  
Heavy Duty

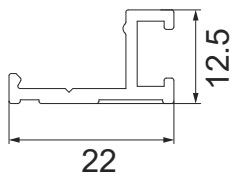

**JM2810**  
Plant on Door Stop

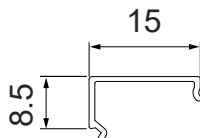

**1688**  
PVC Cover for JM2810

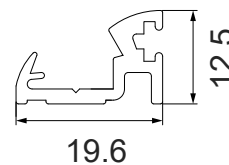

**TJ773**  
Plant on Door Stop

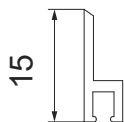

**DB3222**  
15mm Bug Strip Retainer

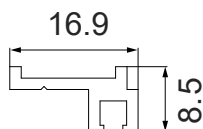

**DB3223**  
Underdoor Bug Strip Retainer

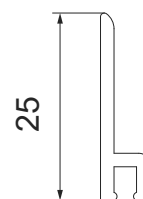

**DB3227**  
25mm Bug Strip Retainer

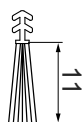

**2590**  
11mm Fringe Pile

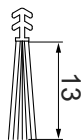

**2600**  
13mm Fringe Pile

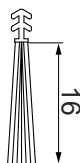

**2610**  
16mm Fringe Pile



**2620**  
28mm Fringe Pile

Additional Profiles

**TJ305**  
Frame Cover  
(Fits AU01016)

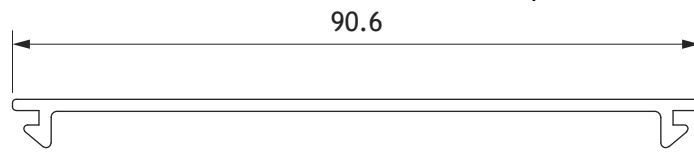

**AU01016**  
Build Out Frame

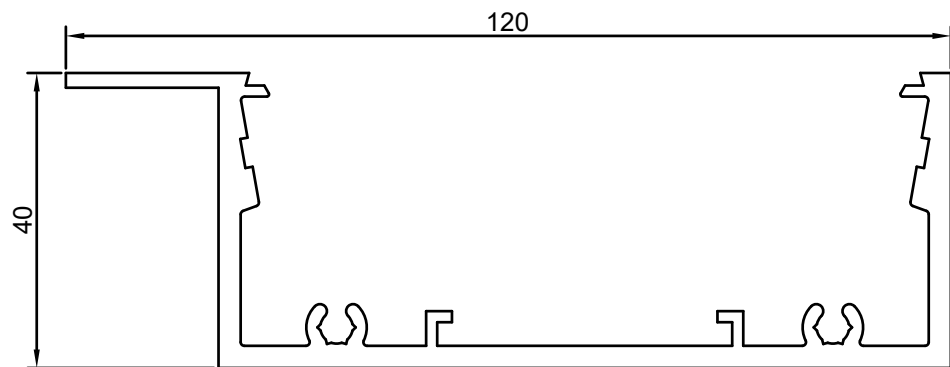

**JM2865**  
Frame Cover  
(Fits SD150)

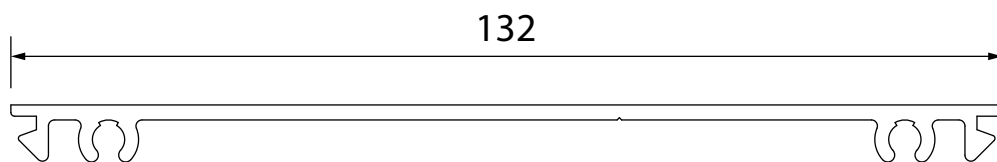

**SD150**  
Build Out Frame

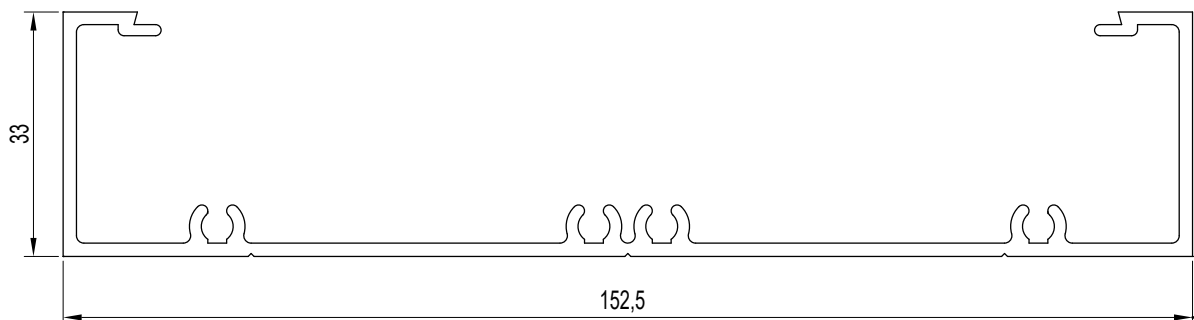

Screenfold Profiles/ Hardware

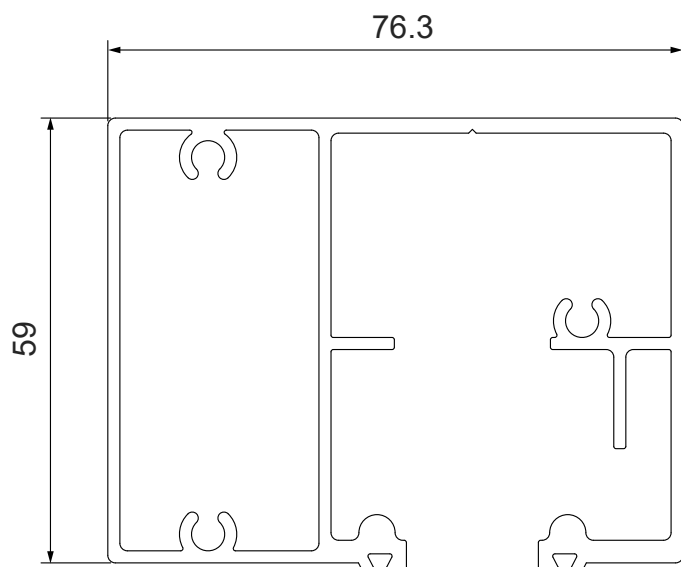

**TJ789**  
76mm Screenfold Head

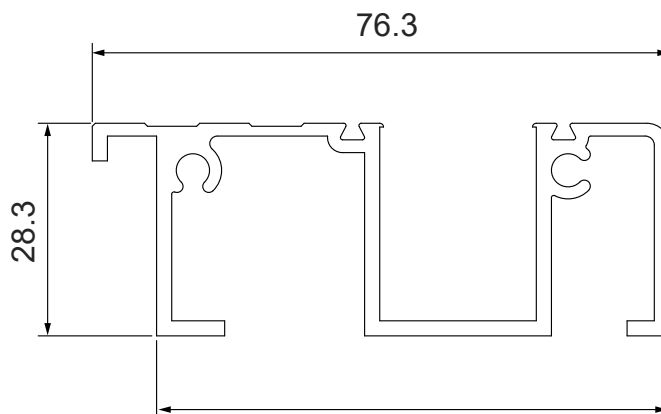

**TJ787**  
76mm Screenfold Sill

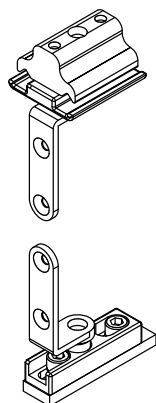

**3301**  
Pivot Assembly Set



**3302**  
Bottom Guide



**3303**  
Hanger

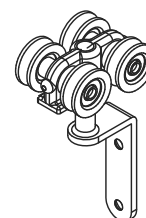

**3313**  
Intermediate Hanger

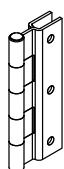

**3305**  
Hinge

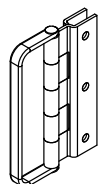

**3306**  
Handle Hinge



**3314**  
Multipoint Bolt  
140mm



**3315**  
Multifold Bolt  
450mm



**3316**  
Maya Bolt

Tools and Equipment

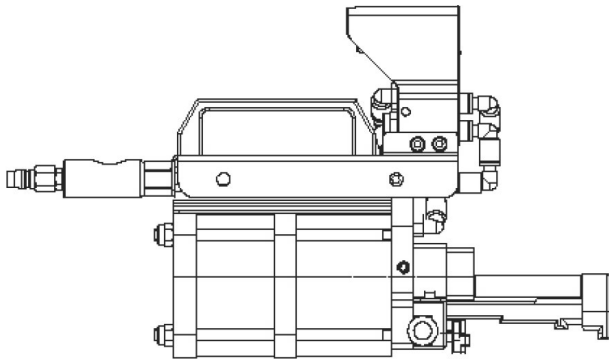

**2920**  
ScreenGuard Air Operated  
Insertion Tool

**Air Compressor:**  
Pressure: *Min 8-10 Bar (115-145 Psi)*  
Volume: *Min 50-100 L*

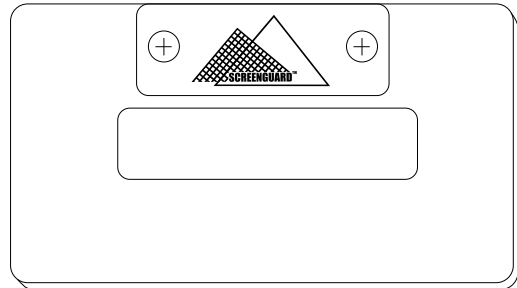

**2921**  
Wedge  
Insertion Block



**2914**  
Window Corner Crimper  
(Air Operated)



**2916-AB**  
Air Operated Stake Punch  
to Suit 2652 & 2659

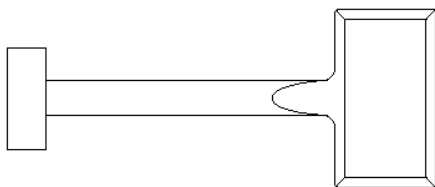

**2515**  
Manual Wedge Assembly  
Tool



-----  
ScreenGuard  
Powash 100ml

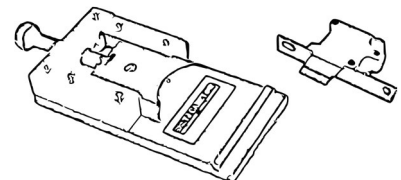

**2915**  
On Site Lock Punch Tool

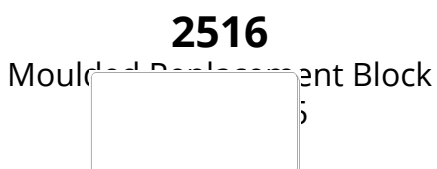

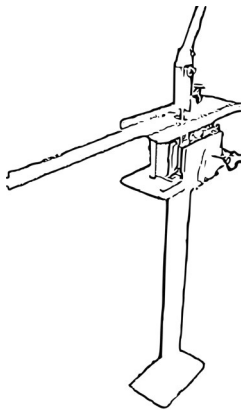

**2910**  
Security Door Punch  
With Stand

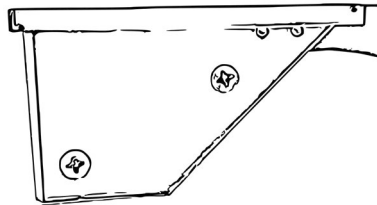

**2917**  
Drill Jig to Suit  
Nylon Corner Stake 2659

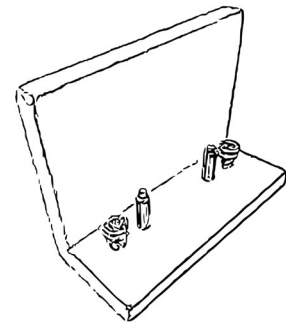

**2919**  
Drill Jig to Suit  
Security Roller



Penteforce Security Screw  
Driver Bit  
50 mm **4F-DB-PF050**  
150MM **4F-DB-PF150**



**4S-PFPH1825SD-G**  
Penteforce Security Screw  
(Self-Tapper, Galvanised,  
8G x 25mm)



**4S-FH1022SD-GAL**  
Flat Head ScREW  
(Self-Tapper, Galvanised,  
10G x 22mm)

Hinged Door Hardware

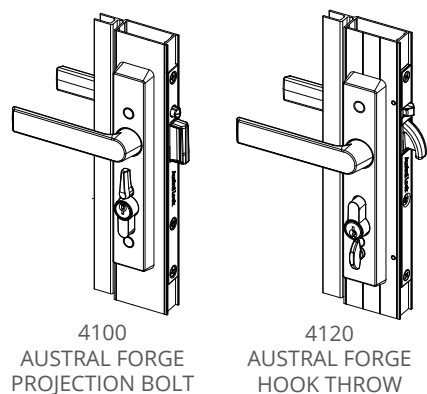

**AUSTRAL LOCKS**

2131	Ultimate XC Hinged Door Lock - No Cylinder (SJ200)
2131 - 3CH	Cable Ultimate 3 Point High Kit (SJ200)
2131 - CH / S	Cable Ultimate 3 Point Low Kit (SJ200)
2131 - 3CL	Cable Ultimate 3 Point Low Kit (SJ200)
2131 - 3CL/S	Cable Ultimate 3 Point Low Straight Kit (SJ200)
2156	Elegance Hinged Door Lock - No Cylinder
2158	Elegance PUSH2GO Hinged Door Lock
2156 - 3CH	Elegance 3 - Point Cable High Kit
2156 - 3CL	Elegance 3 - Point Cable Low Kit
2156 - 3C - ST150	Elegance 3 - Point Cable Kit Short Top Less 150mm
2157 - 3ADJ	Elegance Adjustable 3 - Point Rod Kit
2156 - EXT	Wide Striker Plate For Elegance
4100	Forge Lock Hinged Projection Bolt (Suits 2204/2205)
4120	Forge Lock Hinged Hook Bolt (Suits 2202/2203)

**LOCKWOOD LOCKS**

2105	8654 Hinged Sec Door Lock - No Cylinder
2105 - 3HS	8654 High - Sec 3 Point Lock Kit
2105 - 3ST	8654 Standard 3 Point Lock Kit
2105 - 3PK/PBT	8654 3 Point Lock Kit With Straight Bolts
2105 - EXT	8654 Extra Wide Strike

**YALE LOCKS**

2103	YALE Quattro Hinged Security Door Lock (No Cylinder) -BL(Black), WH(White), PR(Primrose)
2103-3ST	Yale Quattro 3-point Lock Kit

**SECURITY HINGES**

2400	Security Door Hinges
2420	Hinges Packer 1mm Aluminium
2401	Lockwood 316 Stainless Steel Security Door Hinge
2402	Lockwood 316 Stainless Steel Security Door Hinge with Safety Prong

**HINGE DOOR CLOSERS**

2300	Whitco Hinge Door Closer (18kg max.)
2303	Lockwood 403 Hinge Door Closer - (21kg max.)
2301	Austral Hinge Door Closer - (18kg max.)
2305	Doric Hinge Door Closer (18kg max.)
2372	Lockwood 404 Hydraulic Screen Door Closer (29kg max.)
2302	Austral Heavy Duty Door Closer (26kg max.)

Sliding Door Hardware

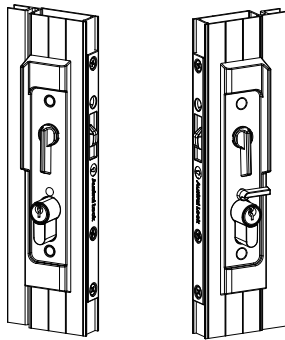

4150 Austral Forge



2151 Austral SD7

2153 Austral SD9

**AUSTRAL LOCKS**

2151	Austral SD7 Sliding Door - No Cylinder (SJ200)
2151 - 3CH	Austral Cable SD7 3 - Point High Kit (SJ200)
2153	Austral SD9 Horizon Sliding Door
4150	Forge Sliding Security Door Lock (Suits 2204/2205) -BL(Black), WH(White)

**LOCKWOOD LOCKS**

2155 - BL	Lockwood 8653 Sliding Door Lock-No Cylinder
2155 -3PT	Lockwood 8653 3 Point Lock Kit
2155 - STK	High Strength Strike to Suit 8653 Lock

**YALE LOCKS**

2154-BL	Yale Quattro Sliding Door Lock - No Cylinder (Black)
2154-3ST	Yale Quattro Sliding Door Lock - 3 Point Lock Kit

**SECURITY DOOR ROLLERS**

2450	Anthony Innovations: AUZ-fit Security Door Roller
2451	KWIKfit Standard & Offset Roller - 40kg

**SLIDING DOOR CLOSERS**

2360	"Easy Close" Sliding Door Closer
2380	"Inventco Water" Sliding Door Closer
2375	Anthony Innovations Soft Door Closer



2155 Lockwood 8653



2154 YALE QUATTRO

## Cylinders and Misc Hardware

### AUSTRAL - CYLINDERS

2204	Pin Cylinder - 60mm Key Alike (Suits SD7 & Elegance Lock)
2205	Pin Cylinder - 60mm Key Differ (Suits SD7 & Elegance Lock)
2202	Pin Cylinder - 60mm Key Alike (Suits Ultimate Lock)
2203	Pin Cylinder - 60mm Key Differ (Suits Ultimate Lock)

### LOCKWOOD - CYLINDERS

2224	Anti Drill 5 Pin Cylinder - 45mm - K/ALIKE
------	--

### WHITCO - CYLINDERS

2200-P	2 x 5 Pin Cylinder - 60mm K/Alike x 10
2201	2 x 5 Pin Cylinder - 60mm K/Differ x 10
2220	2 x 5 Pin Cylinder - 45mm K/Alike x 10
2223	2 x 5 Pin Cylinder - 45mm K/Differ x 10

### MISC.

2290	Whitco Keyed Sliding Push Lock - K/N 32381
2145	Sliding Push Lock, "CYL4" Cylinder
2298	Double Cylinder Deadbolt
2392	Sliding Door Outer Pool
2260 - BL	Whitco 2 Part Flush Bolt - Black
1050	Austral Double Flushbolt For Security Door
2862	Security Door Top Guide to Suit 23.5mm
2863	Security Door Top Guide To Suit 21.2mm
2685	Security Door Corner Gyde Nylon (Suit DF001/003/006, PTD001)
2686	10mm Guide Button For Served Track

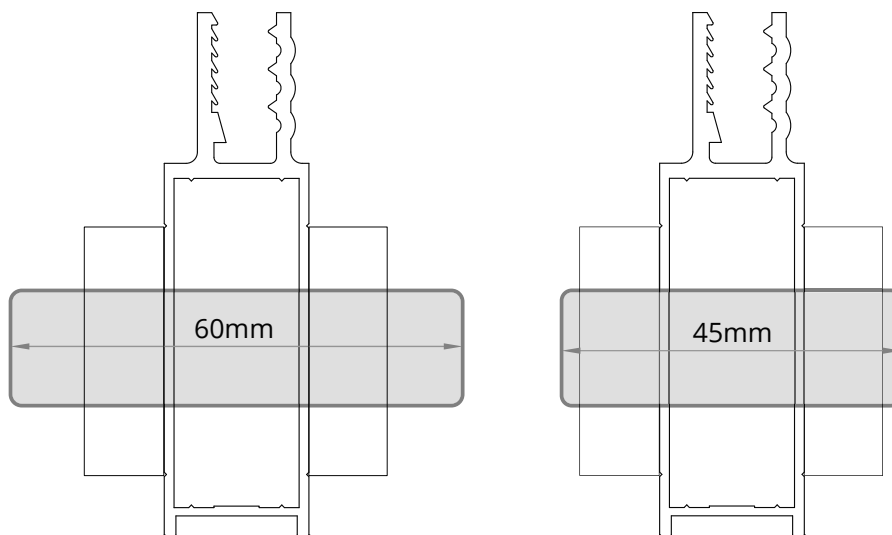

Test Results

Tested Standard	Test Size (W X H)	Product Description	Strand Thickness	Frame	Report No.	Result
-----------------	-------------------	---------------------	------------------	-------	------------	--------

CYCLONIC IMPACT TEST						
AS1170	1615 x 1108	ScreenGuard Extreme Fixed Screen (113mm Buildout)	1.2mm	Door	AZT0612.22	44m/s
AS1170	1110 x 1610	ScreenGuard Extreme Fixed Screen (165mm Buildout)	1.2mm	Door	AZT0101.23	44m/s
AS1170	1520 x 1020	ScreenGuard Extreme Fixed Screen (100mm Buildout)	1.2mm	Window	AZT0311.23	44m/s
AS1170	1460 x 904	ScreenGuard Extreme Fixed Screen (150mm Buildout)	1.2mm	Window	AZT0353.23	44m/s

FORCED ENTRY TEST						
AS5039.2023	860 x 2150	ScreenGuard Extreme Hinged Door	1.2mm	Hinged Door	AZT0446.24	Pass*
AS5039.2023	1312 x 2186	ScreenGuard Extreme Sliding Door	1.2mm	Sliding Door	AZT0444.24	Pass

\* AZT0446.24 Test Result:  
 5x Hits at 100J  
 5x Hits at 200J  
 Additional 19x Hits at 200J  
 (24 Hits at 200J Total)



A Z U M A

TESTED BY NEUTRAL THIRD PARTIES



Security Test Report: Fixed Window

LABORATORY TEST RESULTS:  
ScreenGuard Extreme Fixed Window 100mm Buildout

The following data was obtained from the results of the tests on the ScreenGuard Extreme Fixed Window with 100mm Buildout as performed in the Azuma Testing Laboratory (NATA Accredited).

Performance

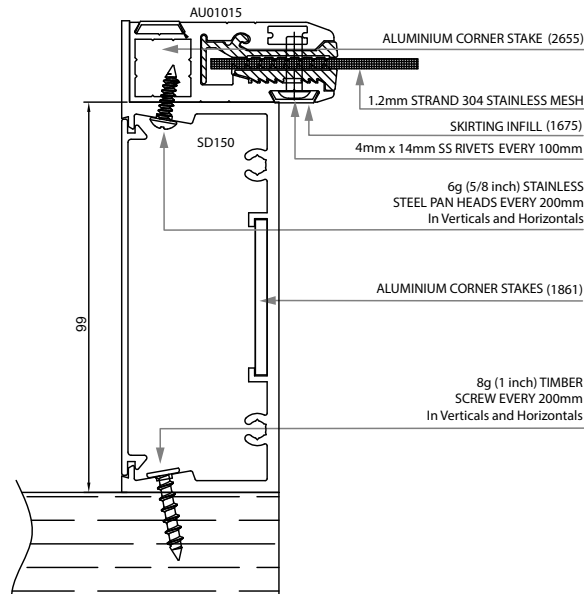

Test & Date	AZT0311.23 - [09/08/2023]
Test Size	1020mm(H) x 1520mm(W)
Type	Fixed Screen
Impact Velocity	44m/s
Load A	Pass
Load B	Pass

Security Test Report: Fixed Window

LABORATORY TEST RESULTS:  
ScreenGuard Extreme Fixed Window 150mm Buildout

The following data was obtained from the results of the tests on the ScreenGuard Extreme Fixed Window 150mm Buildout as performed in the Azuma Testing Laboratory (NATA Accredited).

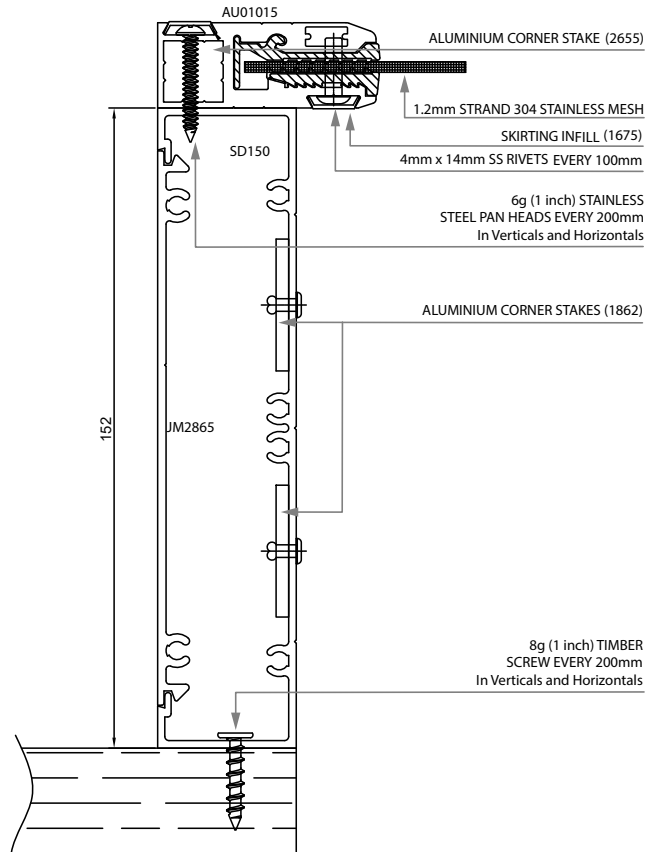

Test & Date	AZT0353.23 - [13/09/2023]
Test Size	904mm(H) x 1460mm(W)
Type	Fixed Screen
Impact Velocity	44m/s
Load A	Pass
Load B	Pass

Performance

Security Test Report: Fixed Window

LABORATORY TEST RESULTS:  
ScreenGuard Extreme Fixed Window 113mm Buildout

The following data was obtained from the results of the tests on the ScreenGuard Extreme Fixed Window 113mm Buildout as performed in the Azuma Testing Laboratory (NATA Accredited).

Performance

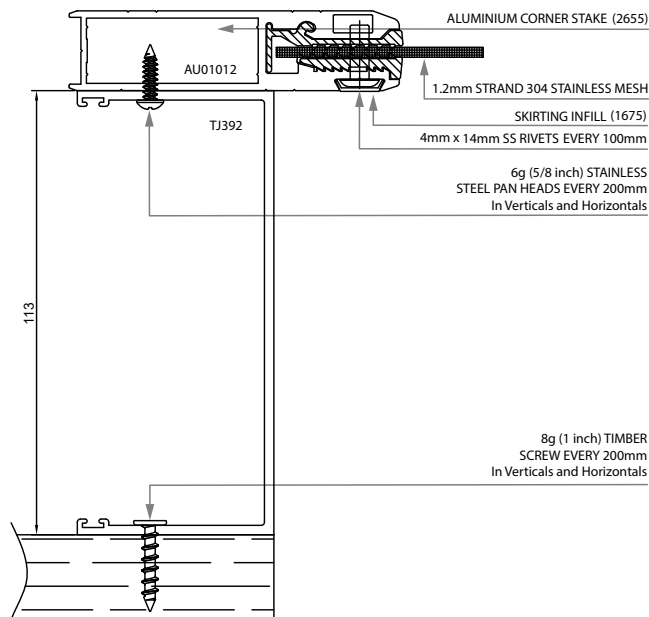

Test & Date	AZT0612.22 - [23/11/2022]
Test Size	1615mm(H) x 1108mm(W)
Type	Fixed Screen
Impact Velocity	44m/s
Load A	Pass
Load B	Pass

Security Test Report: Fixed Window

# LABORATORY TEST RESULTS: ScreenGuard Extreme Fixed Window 165mm Buildout

The following data was obtained from the results of the tests on the ScreenGuard Extreme Fixed Window 165mm Buildout as performed in the Azuma Testing Laboratory (NATA Accredited).

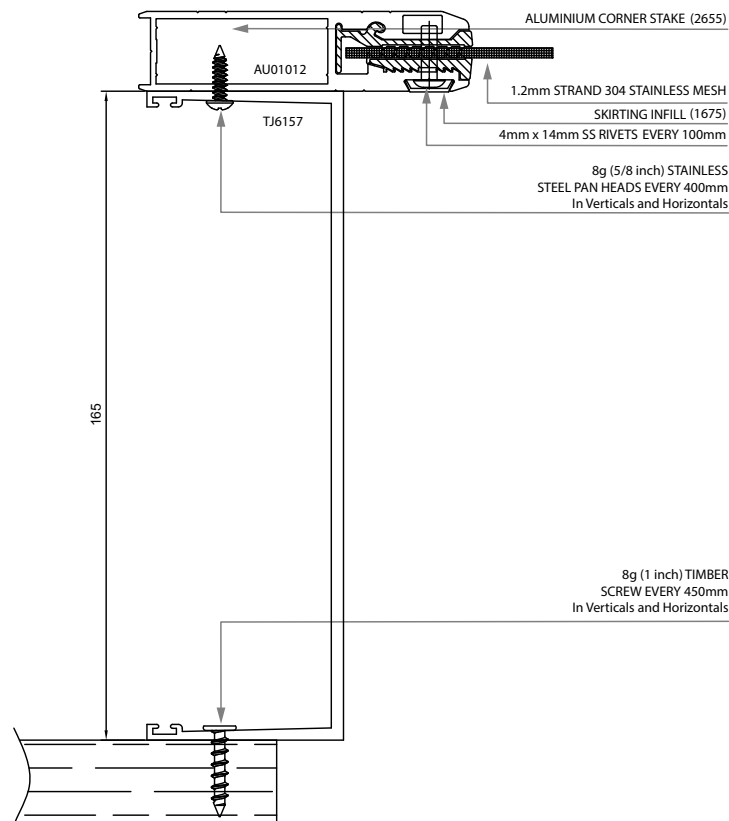

Performance

Test & Date	AZT0101.23 - [05/04/2023]
Test Size	1110mm(H) x 1610mm(W)
Type	Fixed Screen
Impact Velocity	44m/s
Load A	Pass
Load B	Pass

Security Test Report: Hinged

LABORATORY TEST RESULTS:  
ScreenGuard Extreme Security Sliding Door

The following data was obtained from the results of the tests on the ScreenGuard Extreme Security Hinged Door as performed in the Azuma Testing Laboratory (NATA Accredited).

**\* AZT0446.24 Test Result:**  
**Dynamic Impact Test:**  
**5x Hits at 100J**  
**5x Hits at 200J**  
**Additional 19x Hits at 200J**  
**(24 Hits at 200J Total)**

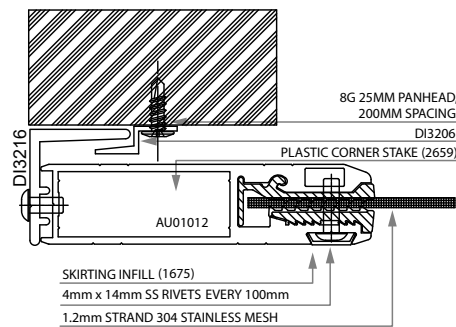

Performance

Test & Date	AZT0446.24 - [29/10/24]	
Test Size	1500mm(H) x 900mm(W)	
Hardware	N/A	
Dynamic Impact Test	100J	PASS
	200J*	PASS
Jemmy Test	PASS	
Pull Test	PASS	
Probe Test	PASS	
Shear Test	PASS	
Knife Shear Test	PASS	



Security Test Report: Sliding Door

LABORATORY TEST RESULTS:  
ScreenGuard Extreme Security Hinged Door

The following data was obtained from the results of the tests on the ScreenGuard Extreme Security Hinged Door as performed in the Azuma Testing Laboratory (NATA Accredited).

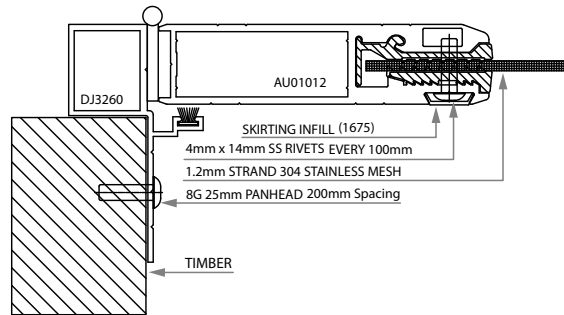

Performance

Test & Date	AZT0444.24 - [29/10/24]	
Test Size	1500mm(H) x 900mm(W)	
Hardware	N/A	
Dynamic Impact Test	100J	PASS
	200J	PASS
Jemmy Test	PASS	
Pull Test	PASS	
Probe Test	PASS	
Shear Test	PASS	
Knife Shear Test	PASS	

## Mesh Sizes

Code	Size	Strand Thickness	Material	Finish	Location
AU2-1224	1200X2400MM	1.2mm	304 STAINLESS	BLACK	Q W
AU2-1524	1500X2400MM	1.2mm	304 STAINLESS	BLACK	Q W
AU2-7524	750X2400MM	1.2mm	304 STAINLESS	BLACK	Q W
AU2-9024	900X2400MM	1.2MM	304 STAINLESS	BLACK	Q W

Fabrication

## Window and Door Mesh Deductions

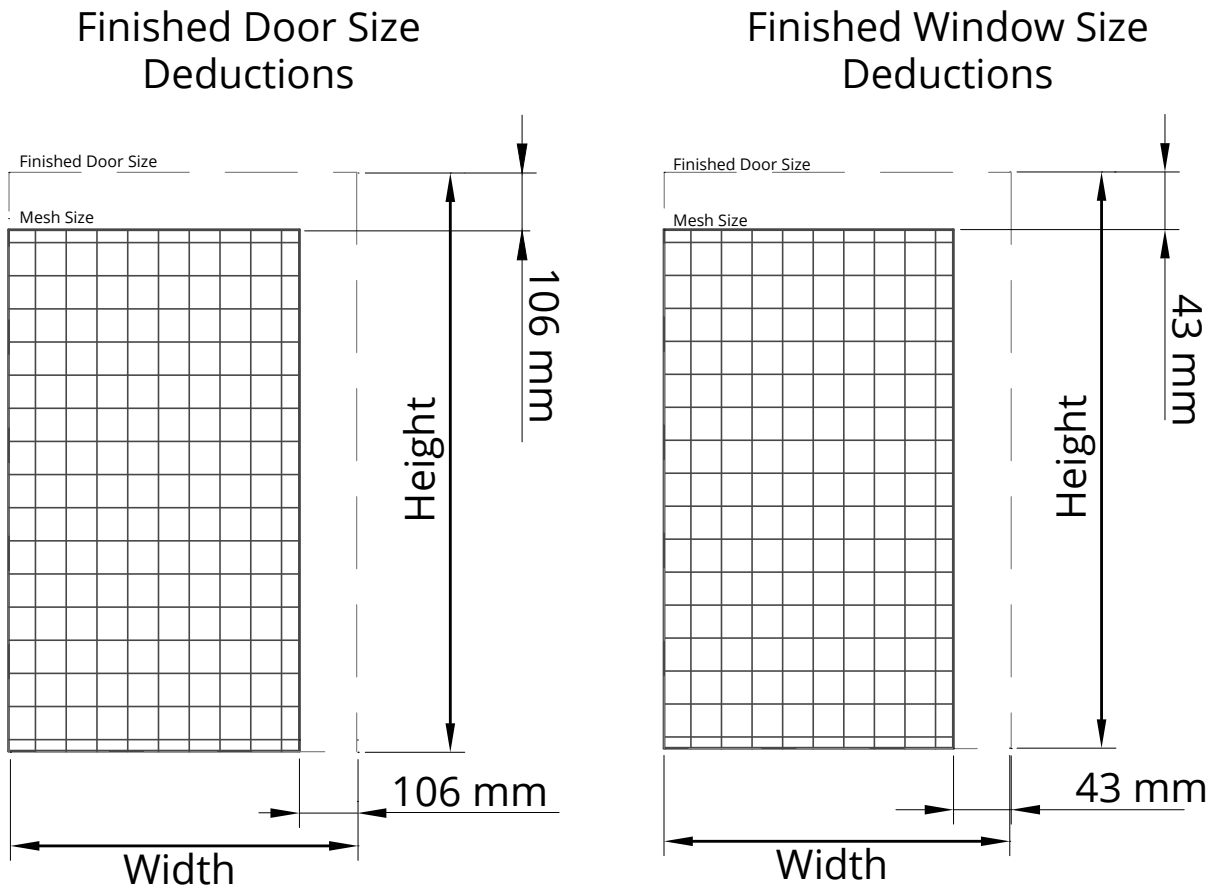

Rail Pre-Loading (Mesh Bow Reduction)

	SCRENGUARD HEIGHT	<2100MM	<2400MM	<3000MM
STEP 1	MESH DEDUCTION (H)	H - 110mm	H - 111mm	H - 114mm
	CLAMPING AMOUNT	4mm	5mm	8mm
	SCRENGUARD WIDTH	<900MM	1200MM	>1200MM
STEP 2	MESH DEDUCTION (H)		W - 106MM	
	CLAMPING AMOUNT		W + 4MM	

(STILES FLARE OUT AFTER STEP 1.  
HANDHELD AIR TOOL DRAGS STILES IN 2MM EACH SIDE)

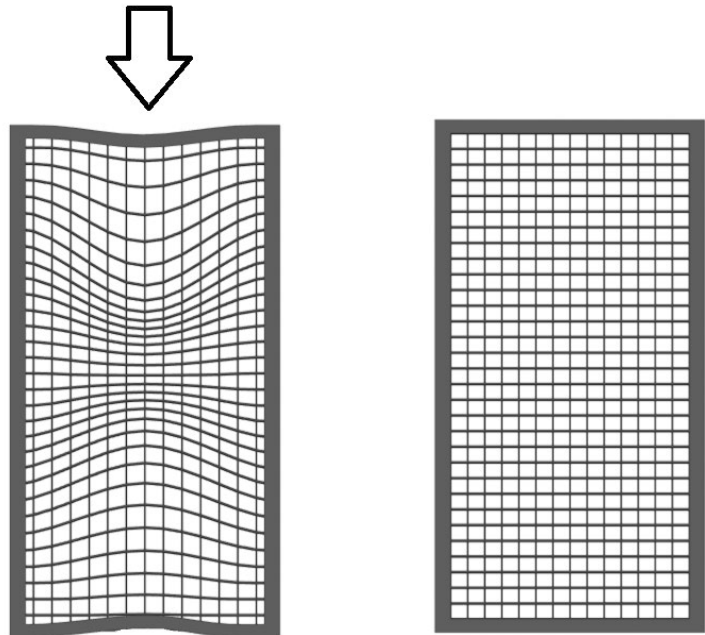

**Rail pre-tension pulls mesh taut then wedge stiles**

**Clamping  
Prior to wedge insertion**

- Screnguard Mesh may not be perfectly flat. In sliding and hinged applications, the mesh can be oriented to avoid any potential fouling, however, in the case of stacking doors, center screen must remain flat.
- Pre-clamping the Prior to wedge insertion allows the frame to straighten the mesh after releasing the clamp.
- It is recommended to pre-tension vertically rather than horizontally for better results. (increased tension)

Fabrication

Assembly

Fabrication

**Step 1**

**Preparing the Frame**

After mitreing window or door frame to required lengths, drill 3x drain holes to top and bottom rails

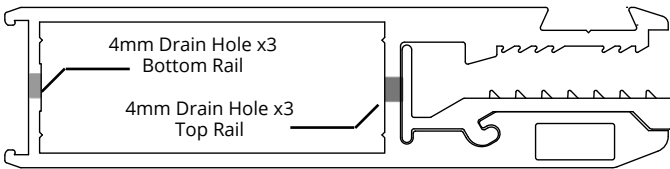

Tip: Apply Lanotec when installing the L seat to make the process easier and faster.

L seat is mitred in corners as per frame. (Ensure L seat is inserted correctly).

**Step 2**

**Inserting the Mesh**

Assemble the frame with corner stakes without fixings/ riveting with one side open for the mesh insertion.

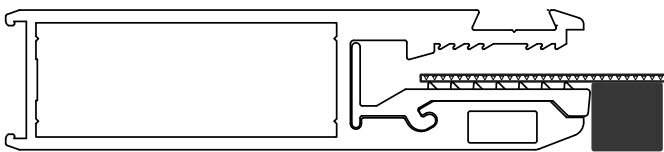

Insert Stainless Steel Mesh.

Sheet to be supported to prevent distortion and to help wedge insertion. 7mm thick high density foam

Tip: After stainless steel mesh has been cut to size, corner tips can be cut at 45 degrees. This will help with the insertion of the mesh.



Ensure the mesh is supported with matting throughout the wedge process to prevent sagging as proper tensioning won't be possible after the wedge insertion. Use 7mm medium- to high-density foam is used to prevent compression under the weight. EVA75 foam is recommended.

**Step 3**

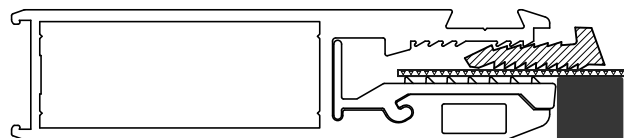

Tap in wedge using our manual tool, automatic air tool or pneumatic hand tool.

Make sure the the frames are clamped as the wedges are being inserted to prevent mesh from bowing. See Page 33



Fabrication

Tip 1: After the first wedge has been inserted, check and measure your door/window widths (top, center, bottom and diagonals).

Tip 2: Keep your wedge in its original condition, store on a flat surface in a dry cool area.

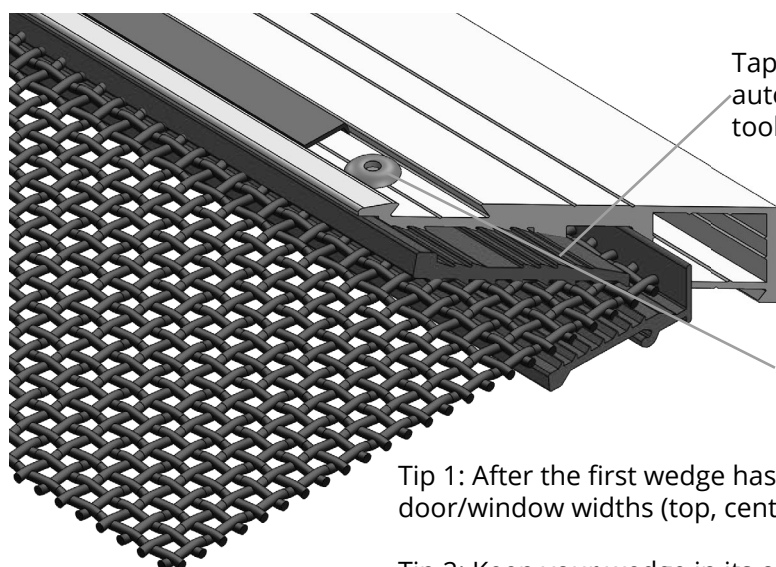

Tap in wedge using our manual tool, automatic air tool or pneumatic hand tool. Refer to diagrams (2) and (3).

Tap in wedge using our manual tool, automatic air tool or pneumatic hand tool. Refer to diagrams (2) and (3).

Use 4mm SS rivets at every 100mm to secure the mesh to the frame. Use the cover strip to conceal the rivets.

Tip 1: After the first wedge has been inserted, check and measure your door/window widths (top, center, bottom and diagonals).

Tip 2: Keep your wedge in its original condition, store on a flat surface in a dry cool area.

# Assembly - Build Out Frame

Fabrication

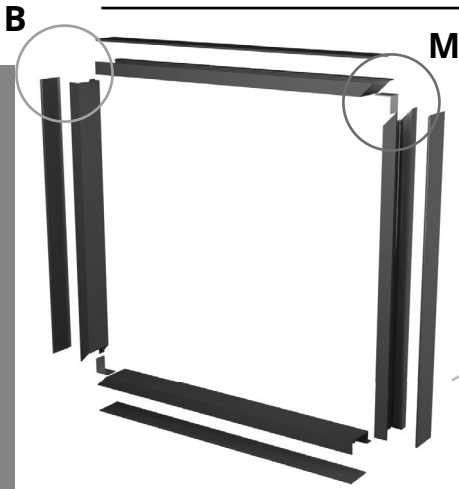

Build out frame should cut to the required lengths and assembled using either mitre joints using corner stakes, or butt joints.

Snap-in fillers are used to hide fixings once installed.

## Options

## Assembly

When using mitre joints, use a combination of corner stakes and screws to align and fix the corners.

For butt joints, use the screw flutes to align and fix the sections.

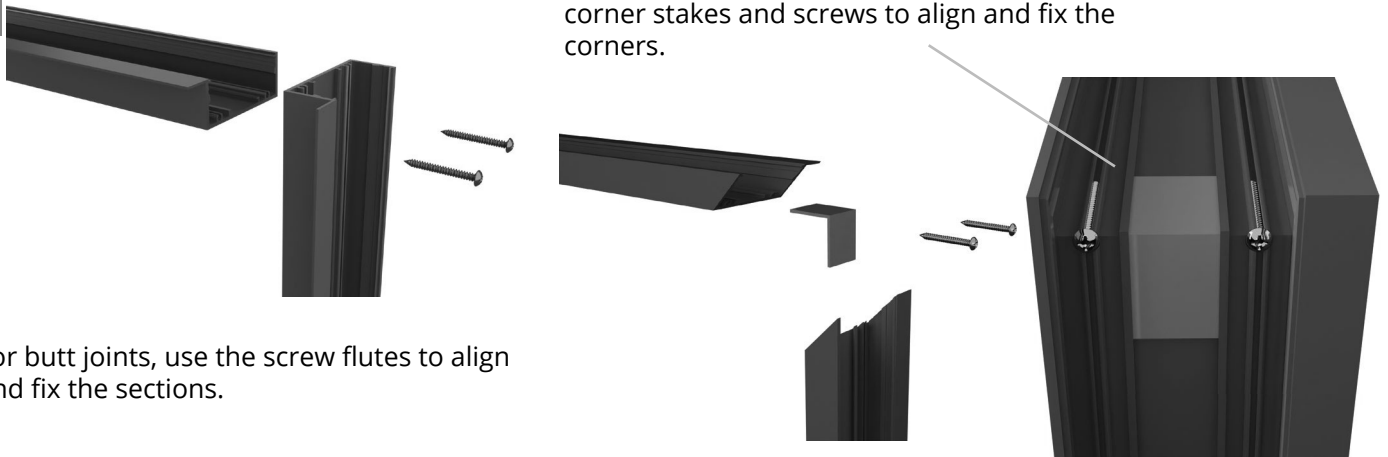

## Mounting

Insert the mesh grille and fix to the frame by driving screws into the alignment groove on the inside of the profile.

The frame can now be fixed to the wall, using the similar alignment groove of the opposite side. Fillers can now be inserted.

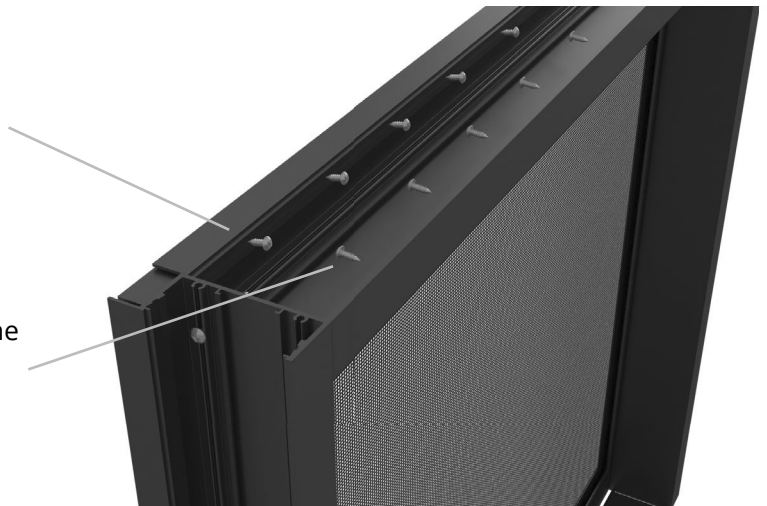

## Fabricator's Instructions

### Stainless Mesh Deductions

Door Mesh = Door size less 106mm on width and height.

Window Mesh = Window size less 43mm on width and height.

### Assembly

- 1.1 After mitring window or door frame to required lengths, select the frame piece that will be the bottom section and drill 3 drainage holes approximately 3-4mm in diameter across internal seating section of door or window frame.
- 1.2 Once frame and mesh is cut to size, lay frame flat on table with rubber L seat inserted ready. L seat is to be mitred in corners as per frame. (Face side down). Refer to Step 1 of Assembly)
- 1.3 Assembly 2 or 3 sides of frame together with corner stakes without riveting and slip mesh into frame section on top of the L rubber seating. Refer to Step 2 of Assembly.
- 2.1 Place 9mm thick medium to high density foam pvc matting under stainless mesh sheet but not under any portion of the frame. (This will avoid any bellying of mesh).  
PVC foam matting should be used in a few places to provide adequate support to the whole mesh.
- 2.2 Complete the frame - square up door or grille and rivet/screw corners as per security industry standards
- 3.1 Measure the top and bottom frame rails with a wedge. Score wedge on 1 side with Stanley knife and snap off at score. Tap in wedge using a solid pvc or similar block, into the opposing sides. Finally measure remaining 2 lengths with wedge, score and snap these lengths to complete door or window.  
Refer to Step 3 of Assembly.
- 3.2 Rivet every 100mm around the frame into pre-punched holes.
- 3.3 Insert cover strip to conceal fixings

### **IMPORTANT:**

Ensure matting is supporting mesh in the middle during whole wedge process. Along with matting support the wedge process tensions in the mesh - if mesh sags without the correct support it will not tension later. It is also important that the support matting be 9mm and of a medium to high density as to support the mesh without compressing under the weight. For best density we recommend "EVA 75" foam.

Sliding Door Head and Sill Options

Fabrication

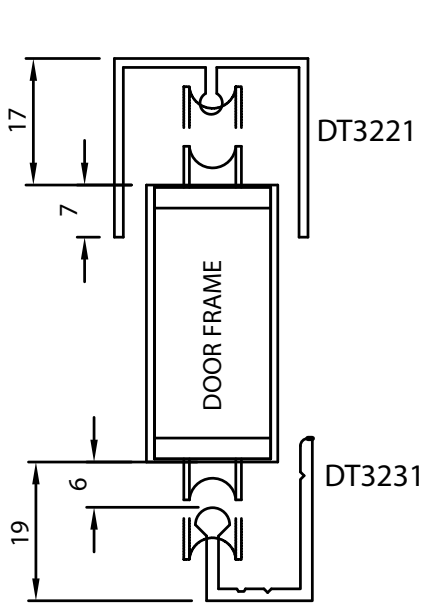

PANEL HEIGHT = H - 36

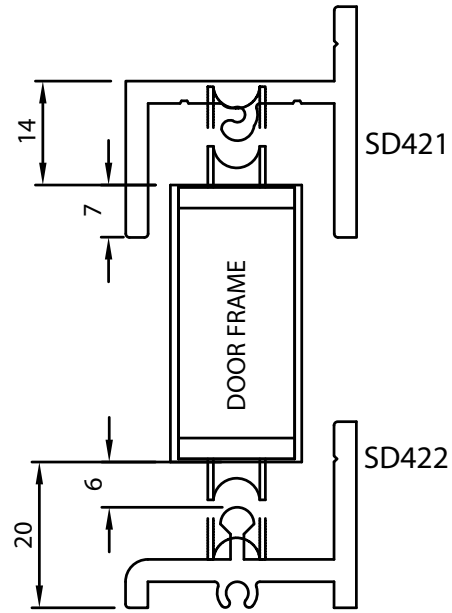

PANEL HEIGHT = H - 34

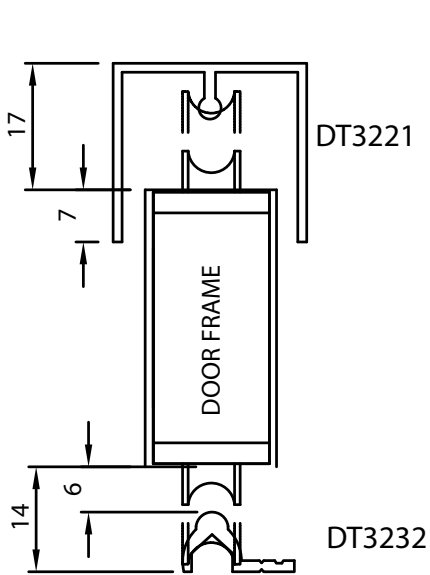

PANEL HEIGHT = H - 31

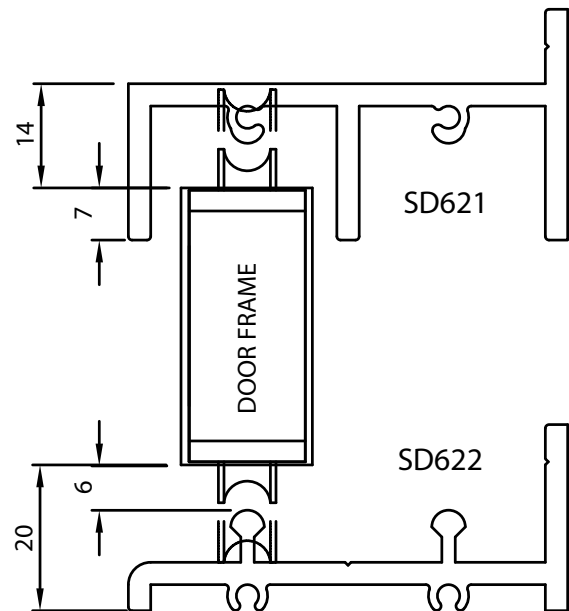

PANEL HEIGHT = H - 34

Sliding Door Jamb Options

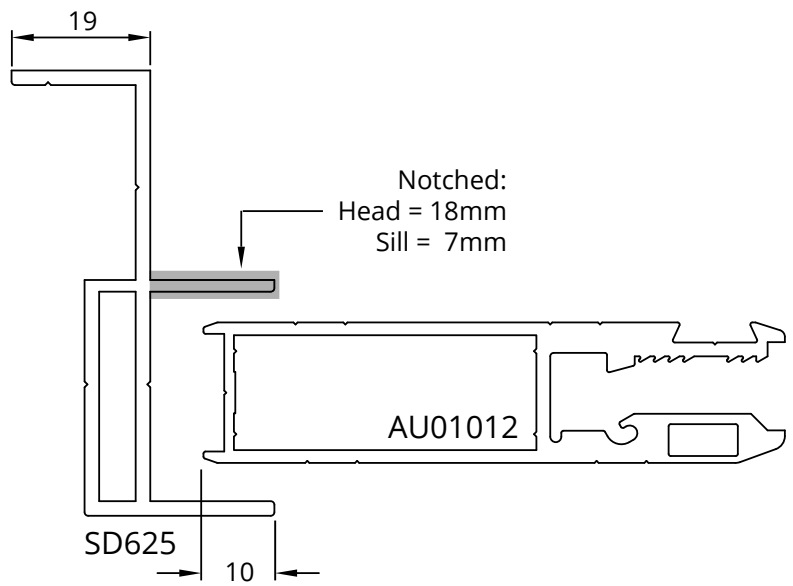
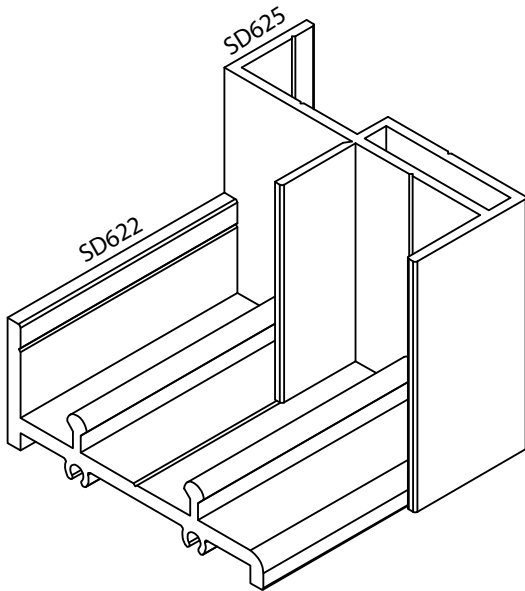
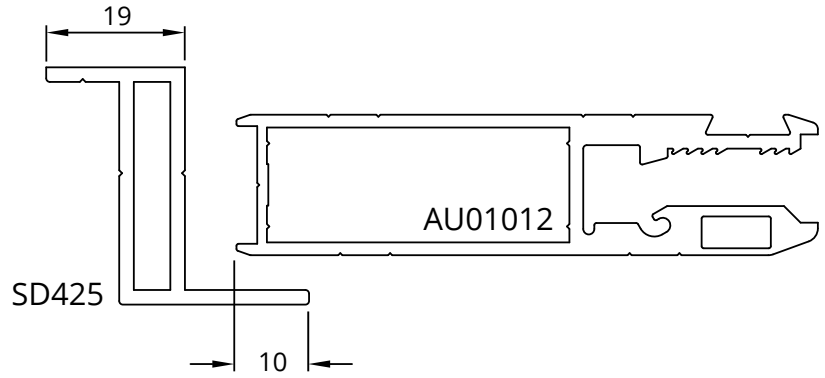
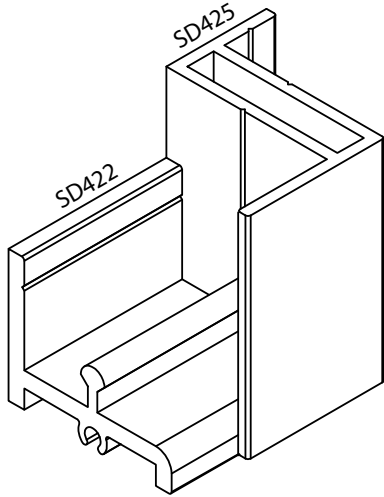

Sliding Door Interlock Options

**CityView Architectural Door**

**CityView Patio Door**

Fabrication

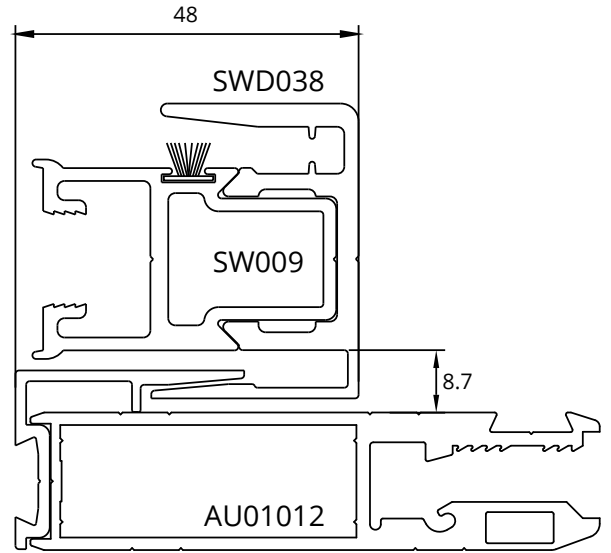
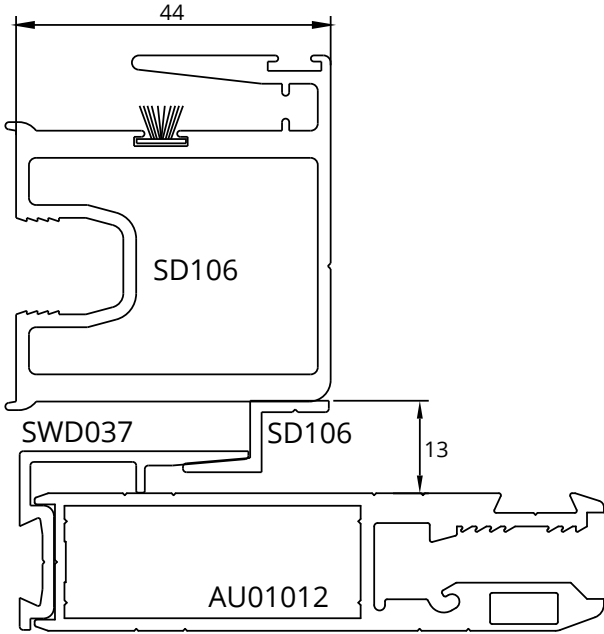

**Klassic View Sliding/Stacker**

**ScreenGuard Extreme Interlocking**

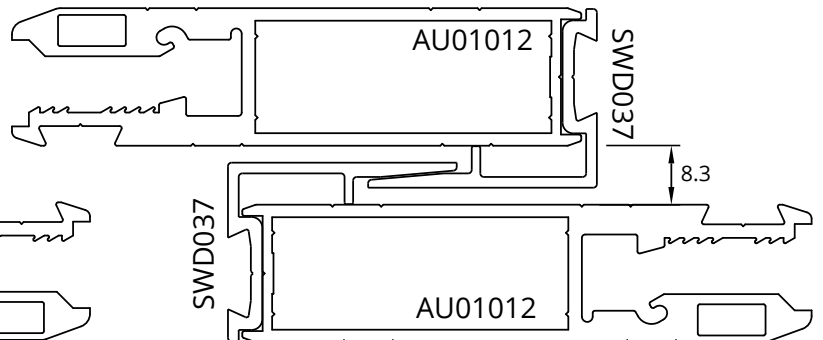
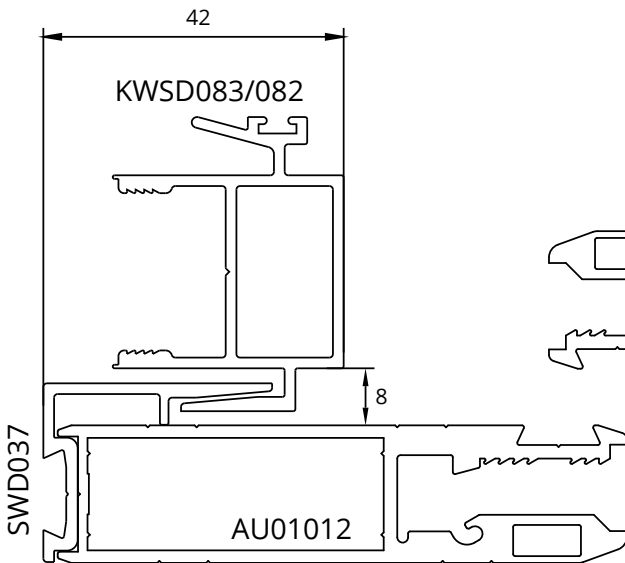

Hinged Door Options

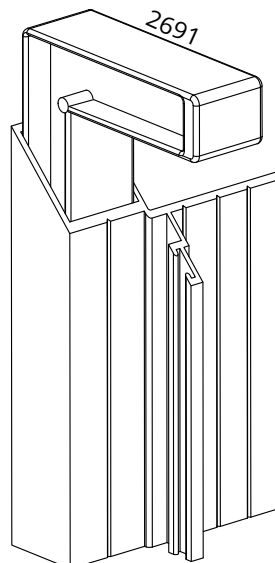
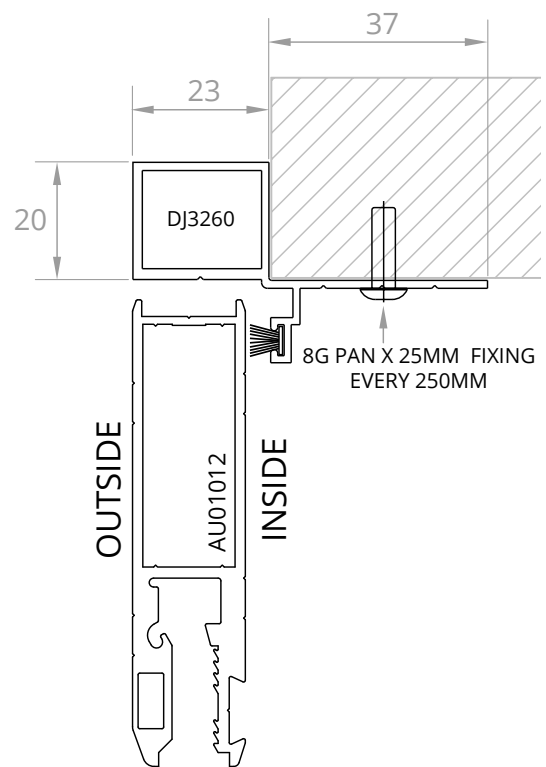
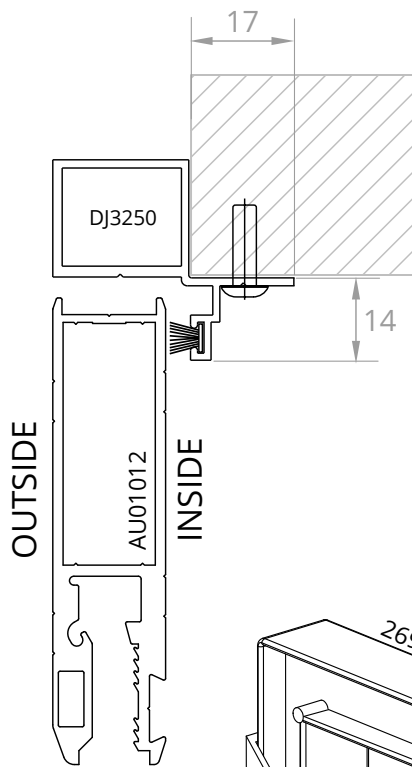
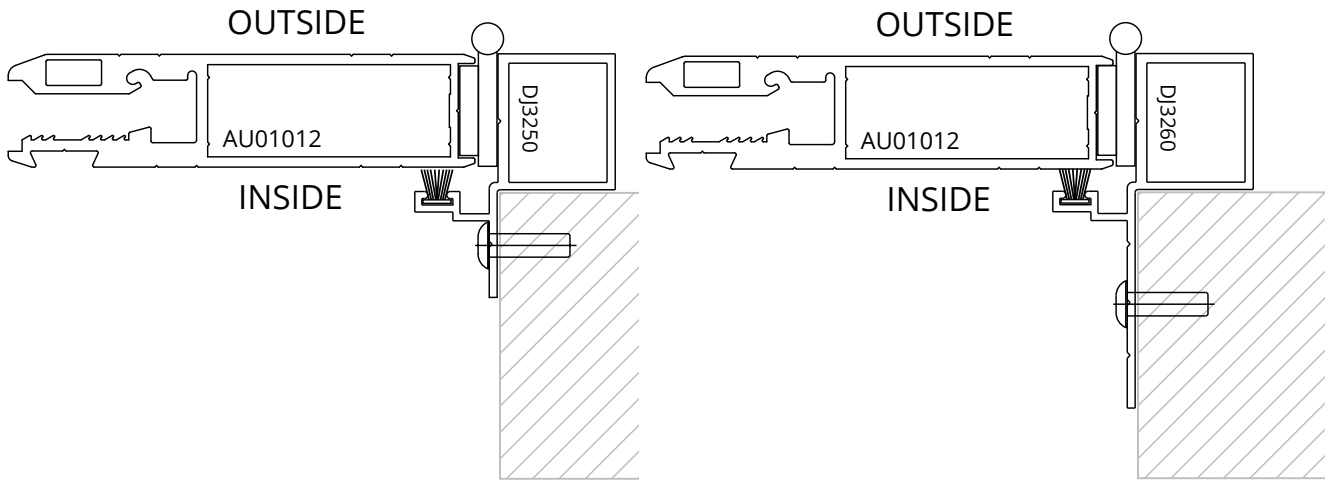

HEAD = OPENING + 40MM  
45 MITRED BOTH ENDS

JAMB = OPENING + 20MM  
45 MITRED BOTH ENDS

Fabrication

# Double Hinge Door Cover Options

NOTE: 5mm between striker plate and lock face plate.

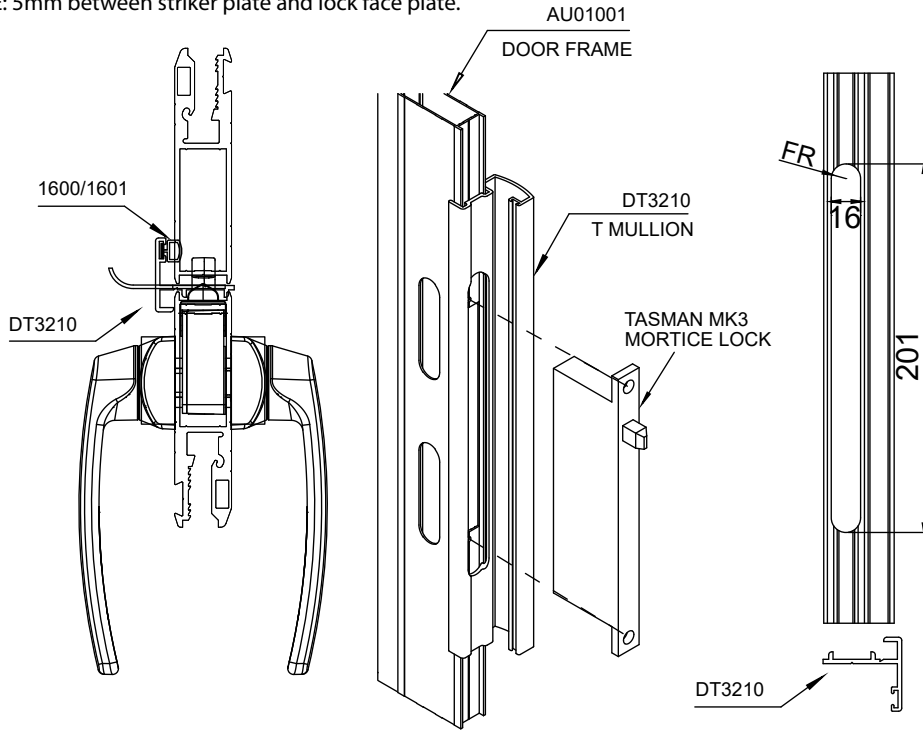

OUTWARD OPENING SCREENS

INWARD OPENING SCREENS

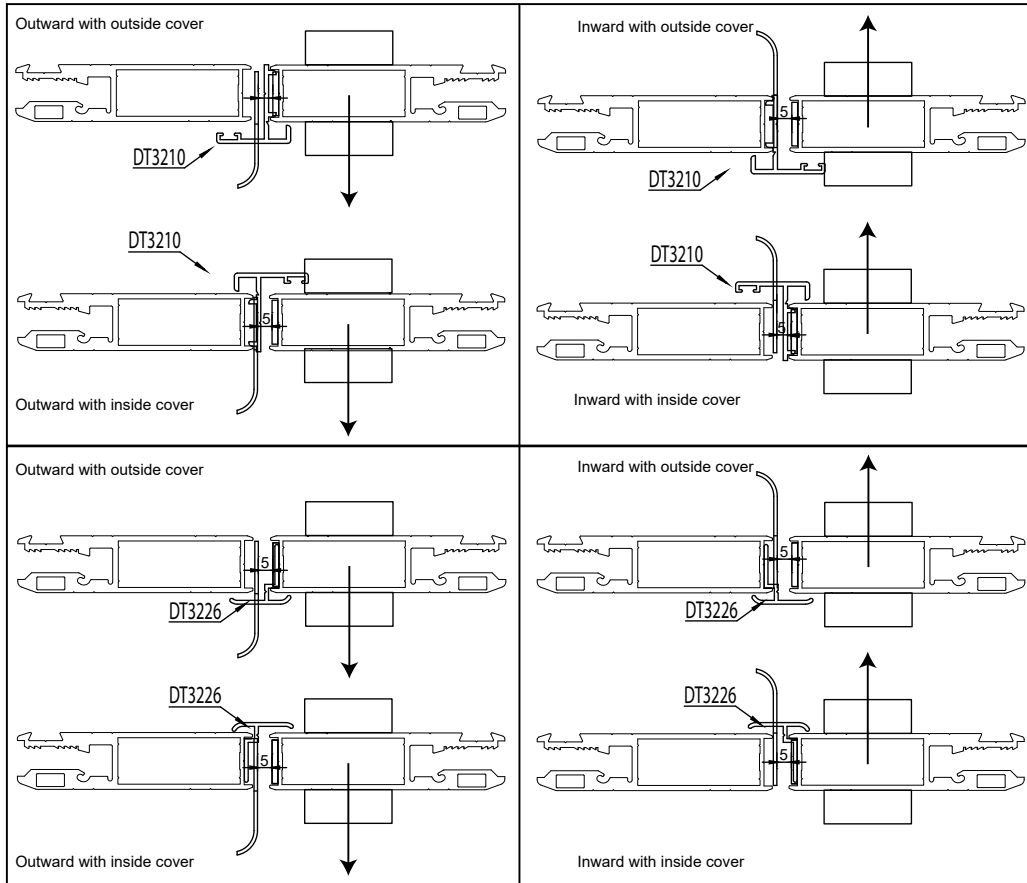

Fabrication

# Additional Machining Details

LEFT: Triple lock cutout and centre lock body cutout. Vertical positioning dependent on lock choice.

BELOW: Standard lock handle cutout (machine both faces of stile). Vertical placement central with lock body cutout.

64

160

172

137

19

84

64

NOTE: To avoid handle fouling with main door handle, screen door handle should offset. Refer to lock options for high, low and standard kits. Refer to instructions included with lock choice for vertical placement.

2659 Nylon Corner Stake hole locations.

100.5

48.5

Ø3

Ø3

2450 Roller adjustment hole location and cutout location.

125 for nylon two hole corner stake

91.5 for metal corner stake

46

23

39

Ø8

Fabrication

Austral Elegance (2156) / Austral Forge (4300)



3PT Lock Installation  
Instruction Video

Fabrication

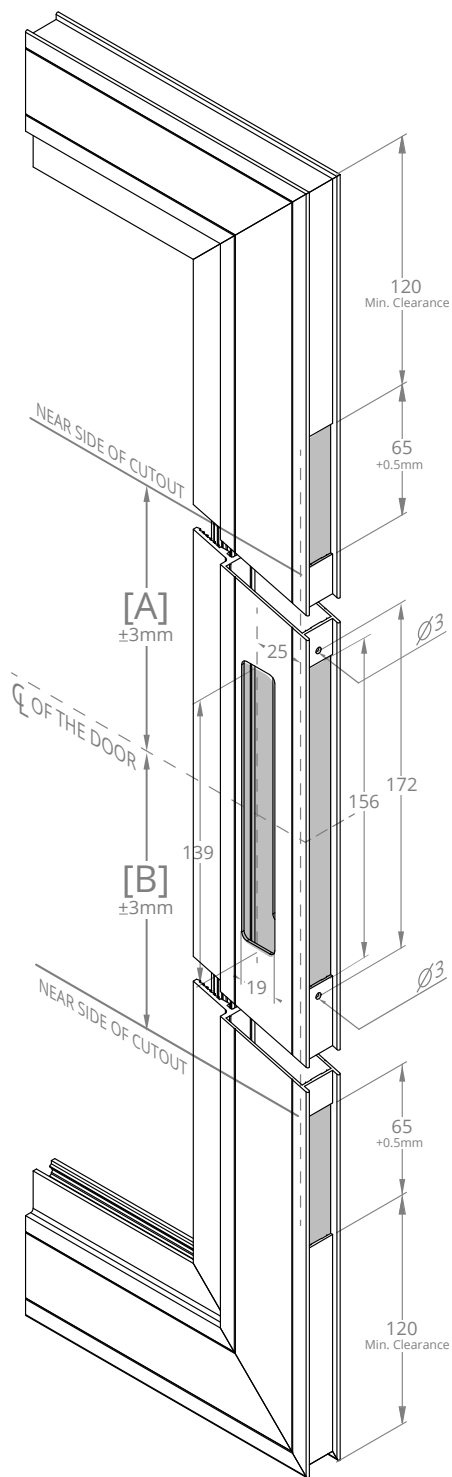

HARDWARE	CODE	[A]	[B]
HIGH KIT	2156-3CH	826mm	682mm
LOW PIVOT KIT	2156-3CL	682mm	826mm
ADJUSTABLE ROD	2157-3ADJ	110mm-980mm (ONE SIDE)	

Austral Ultimate (2131) / Austral Forge (4100)

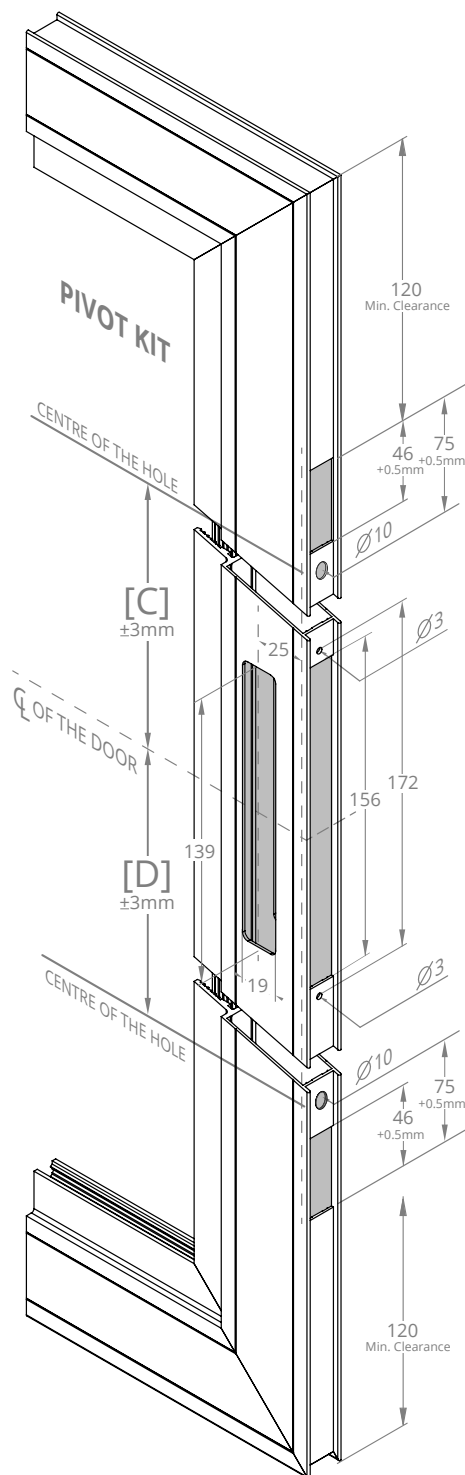
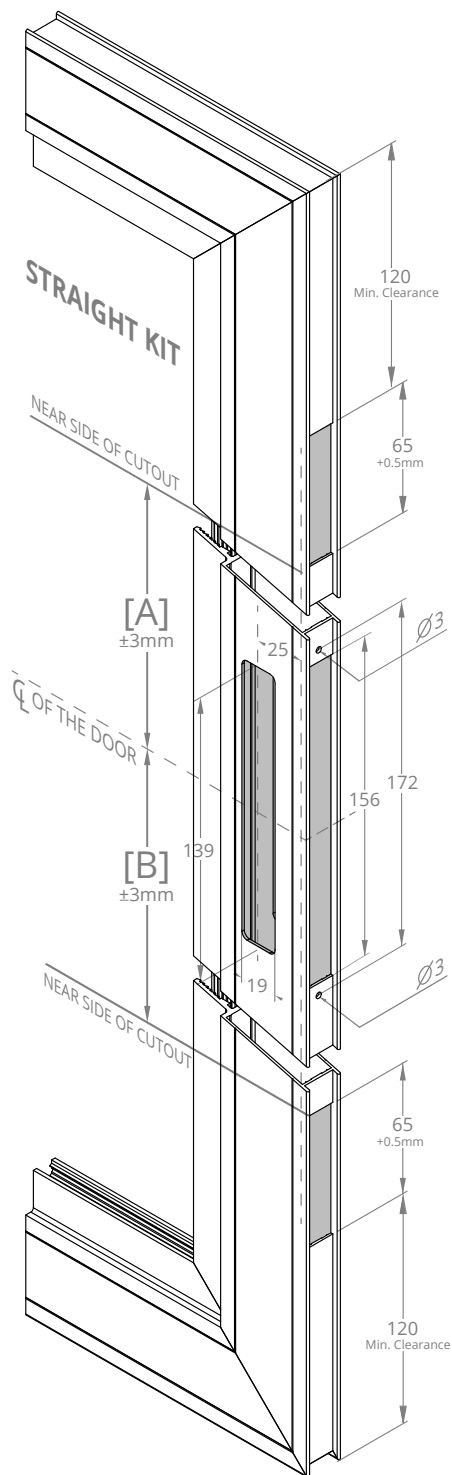

Fabrication

HARDWARE	CODE	[A]	[B]	[C]	[D]T
HIGH PIVOT KIT	2131-3CH	-	-	610mm	790mm
HIGH STRAIGHT KIT	2131-CH/S	682mm	826mm	-	-
LOW PIVOT KIT	2131-3CL	-	-	766mm	634mm
LOW STRAIGHT KIT	2131-CL/S	682mm	826mm	-	-



Lockwood 8654 Hinged Door Lock (2105)

Fabrication

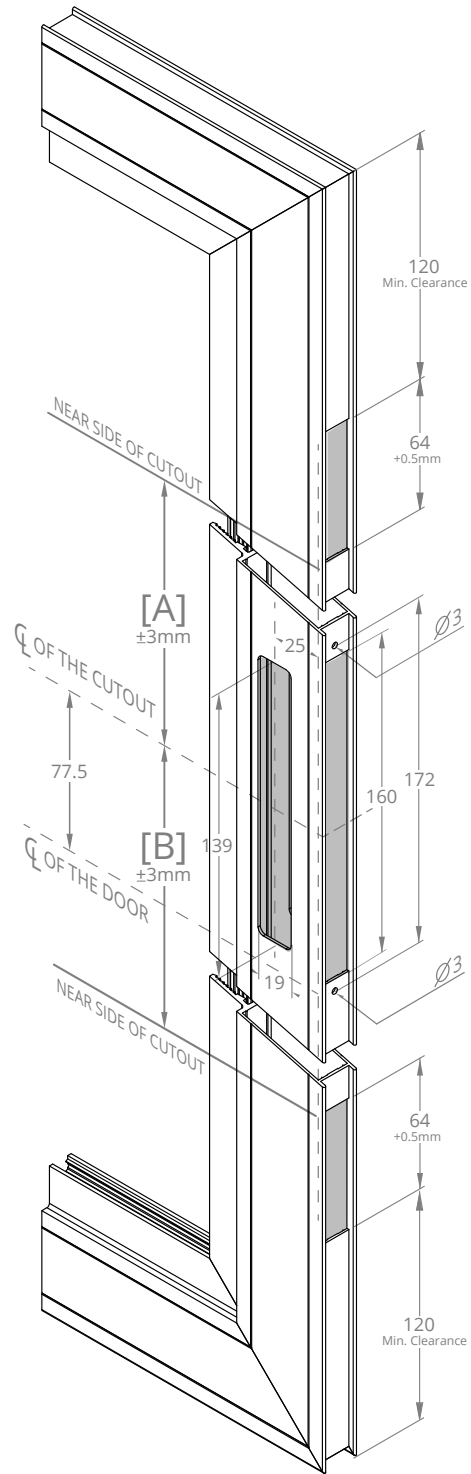
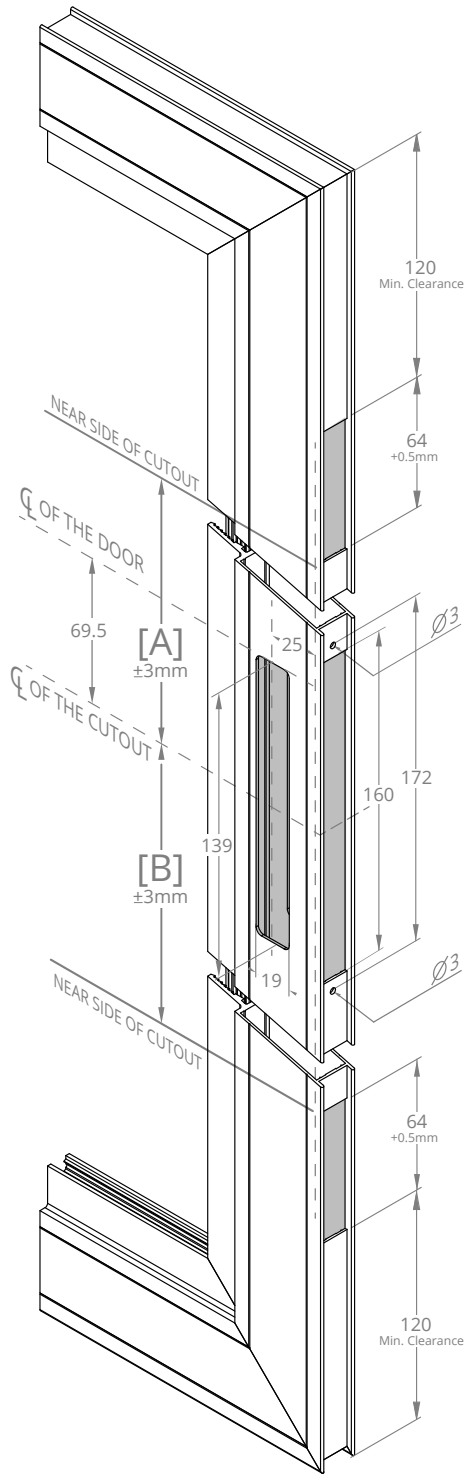

HARDWARE	CODE	[A]	[B]
HIGH KIT	2105-3HS	825mm	682mm
STANDARD KIT	2105-3ST	682mm	829mm
PROJECTION BOLT	2105-3PK/PBT		



Yale Quattro Hinged/Sliding Door Lock (2103 / 2154)

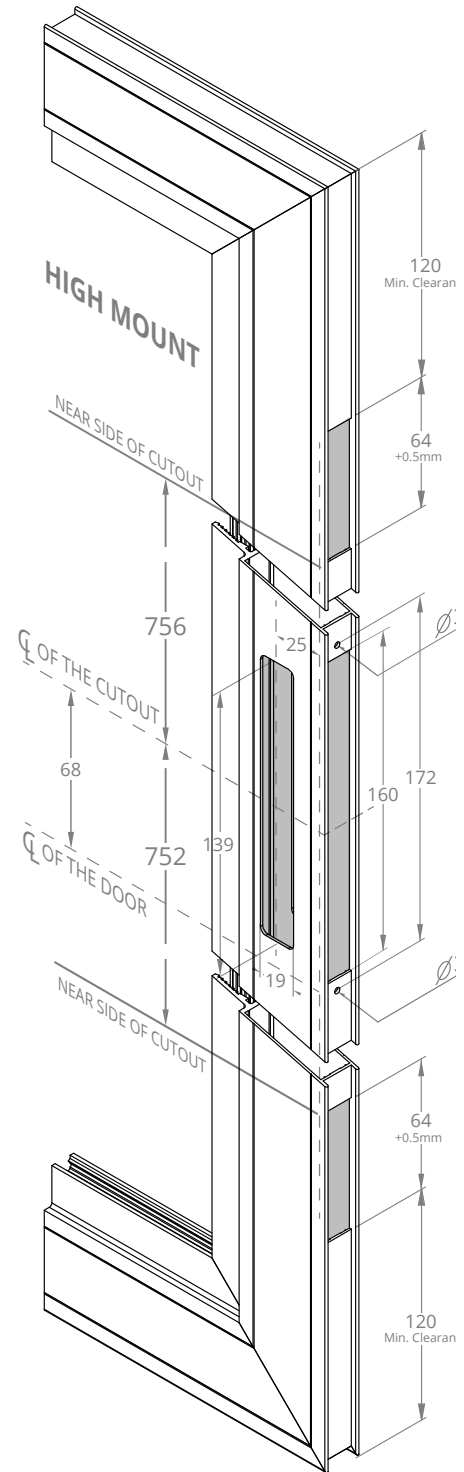
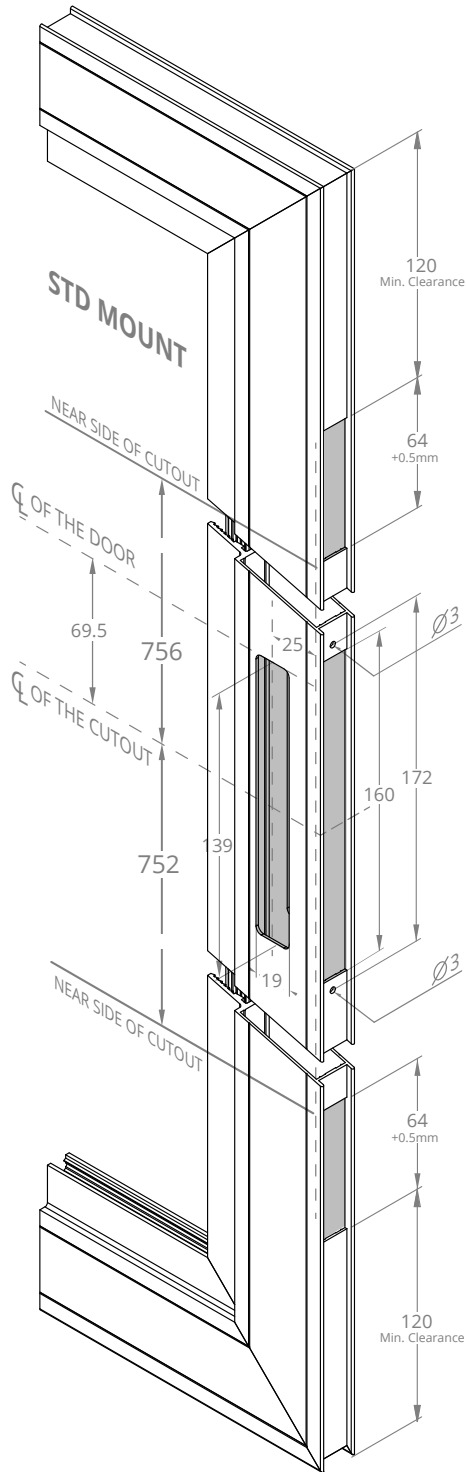

**HARDWARE**

**CODE**

**[A]**

**[B]**

HINGED DOOR

2103-3ST

756mm

752mm

SLIDING DOOR

2156-3ST

756mm

752mm



Fabrication

Lockwod 8653 Sliding Door Lock (2155)

Fabrication

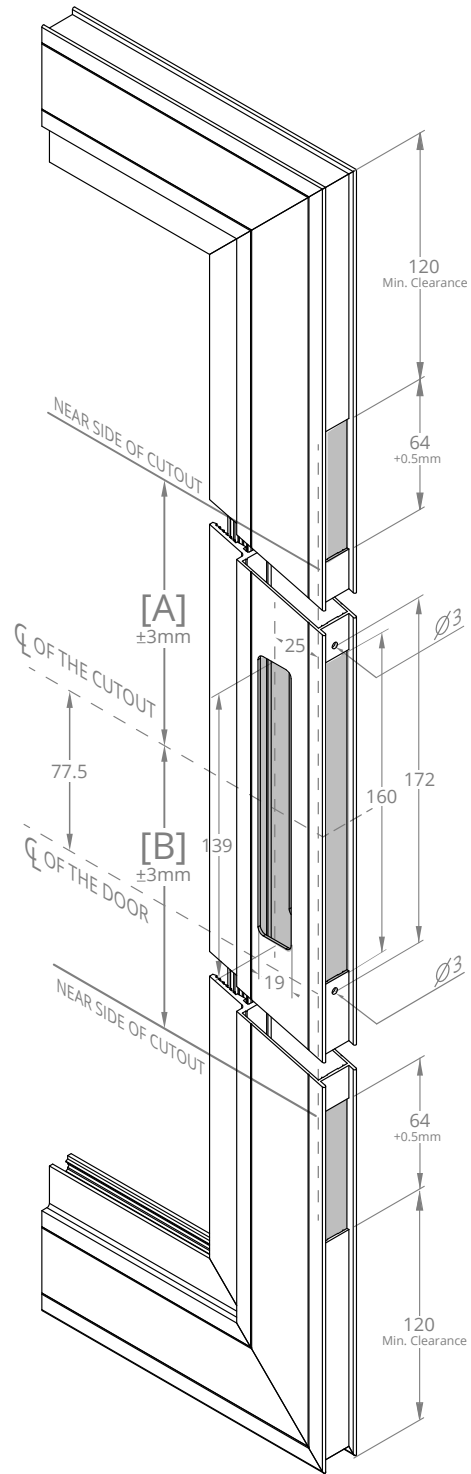
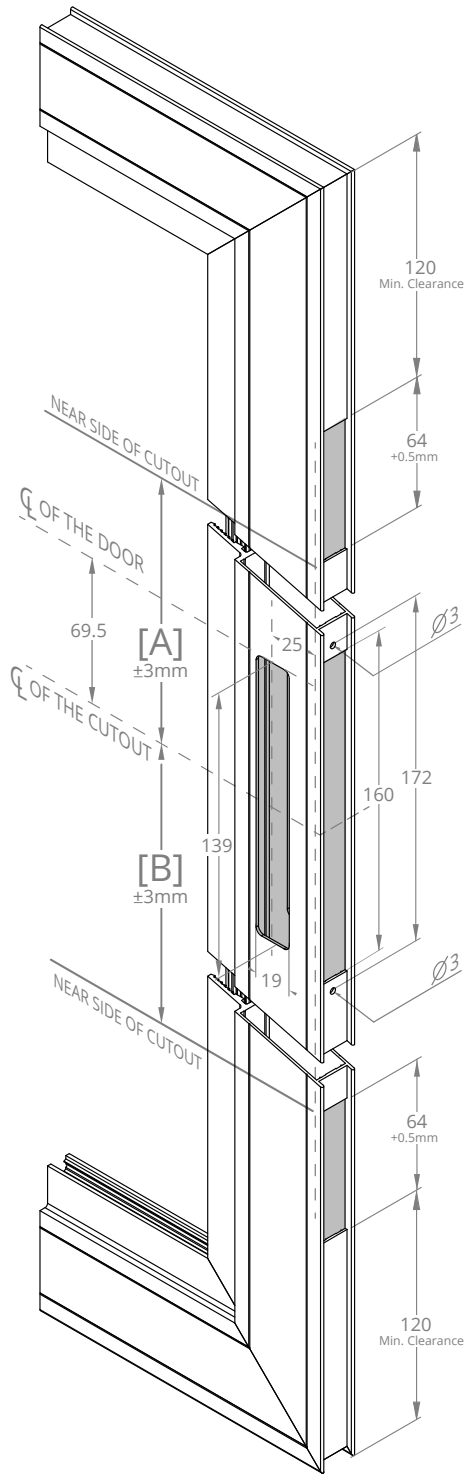

**HARDWARE**

**CODE**

**[A]**

**[B]**

STANDARD KIT

2155-3ST

756mm

752mm

SNIB ONLY

2155-SO

756mm

752mm



Austral SD7 Sliding Door Lock (2151)



3PT Lock Installation  
Instruction Video

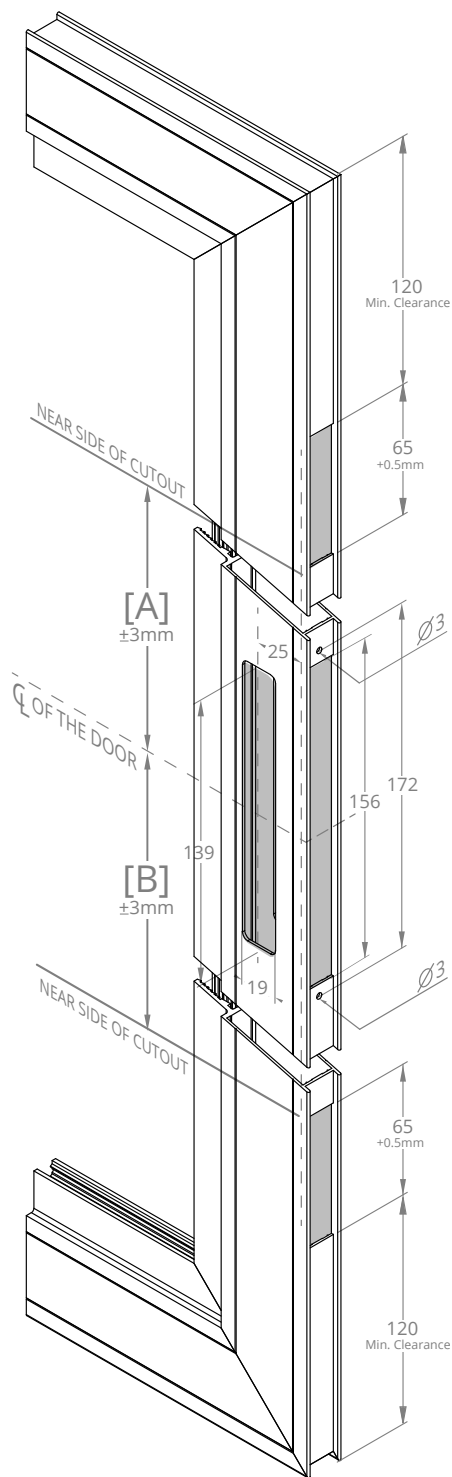

HARDWARE	CODE	[A]	[B]
HIGH CABLE KIT	2151-3CH	546mm	961mm
ADJUSTABLE ROD KIT	2151-3ADJ	ANY	
SD9 LOCK	2153		

Fabrication

KWIKfit Switch Offset Roller (2451)

Fabrication

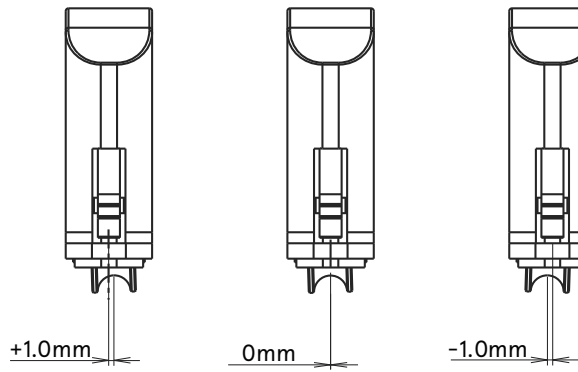

Supplied in zero offset wheel position

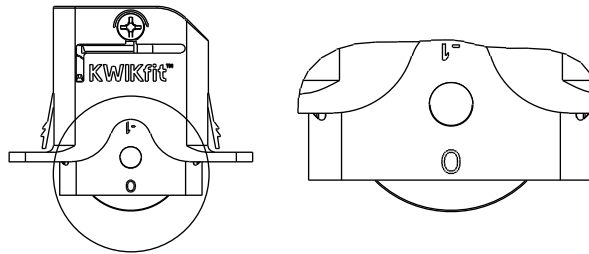

To achieve a -1mm offset follow below:

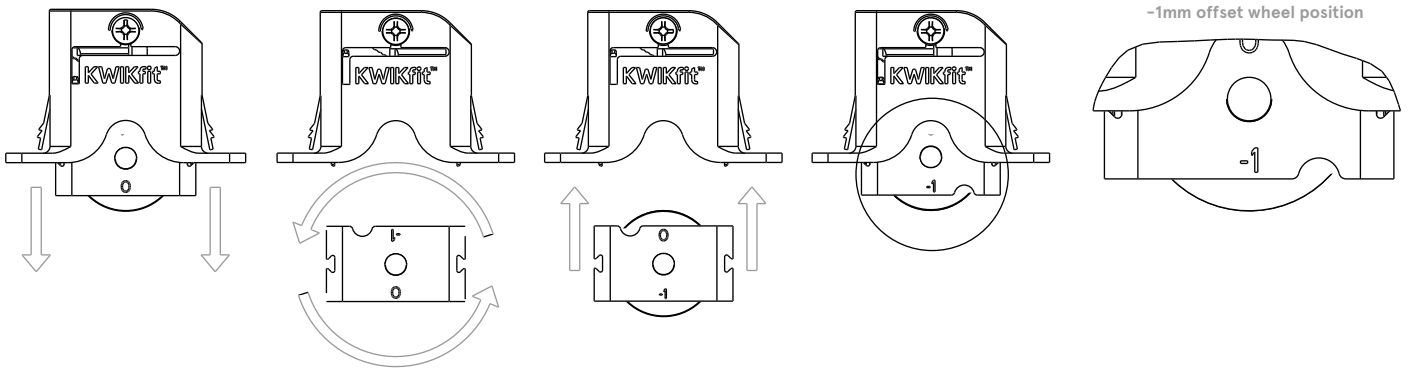

To achieve a +1mm offset follow below:

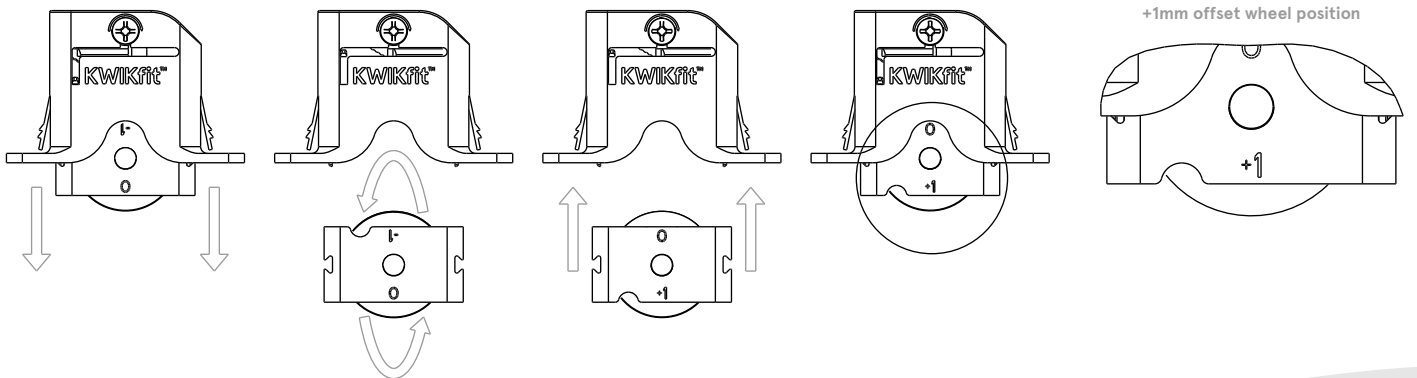

Barrier Multifolding Doors

General Configuration

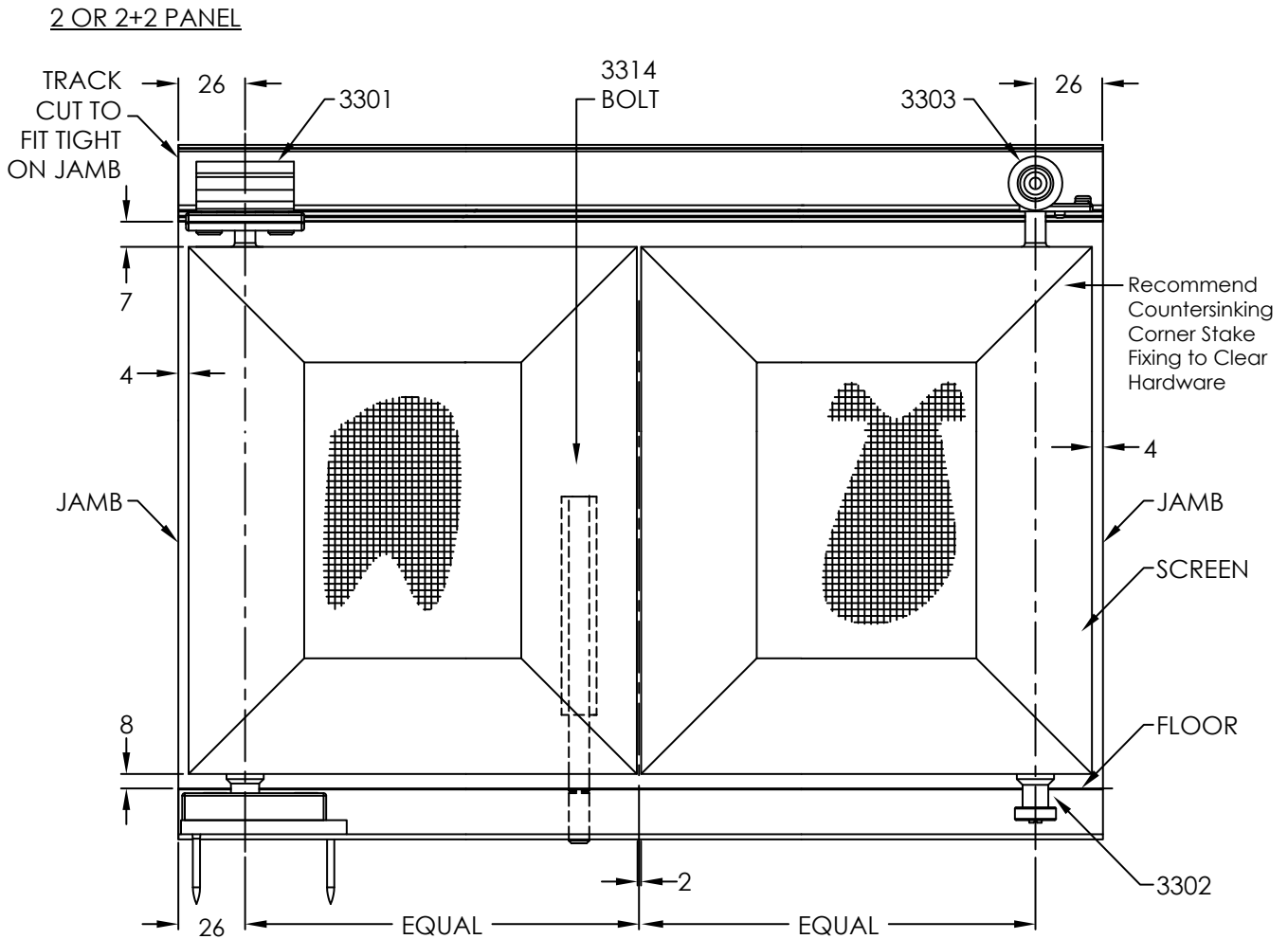

Fabrication

Size Deductions

Recommended maximum panel weight: 25kg

Recommended maximum panel width: 900mm

Height Deduction	
Above Ground Track	Screenfold Frame Size - 101 = Panel Size
In Ground Track	Screenfold Frame Size - 73 = Panel Size

Width Deduction	
2 Panel	(Screenfold Frame Size - 80)/2 mm
3 Panel	(Screenfold Frame Size - 82)/3 mm
4 Panel	(Screenfold Frame Size - 84)/4 mm
5 Panel	(Screenfold Frame Size - 86)/5 mm
6 Panel	(Screenfold Frame Size - 88)/6 mm

Head & Sill Diagrams

Fabrication

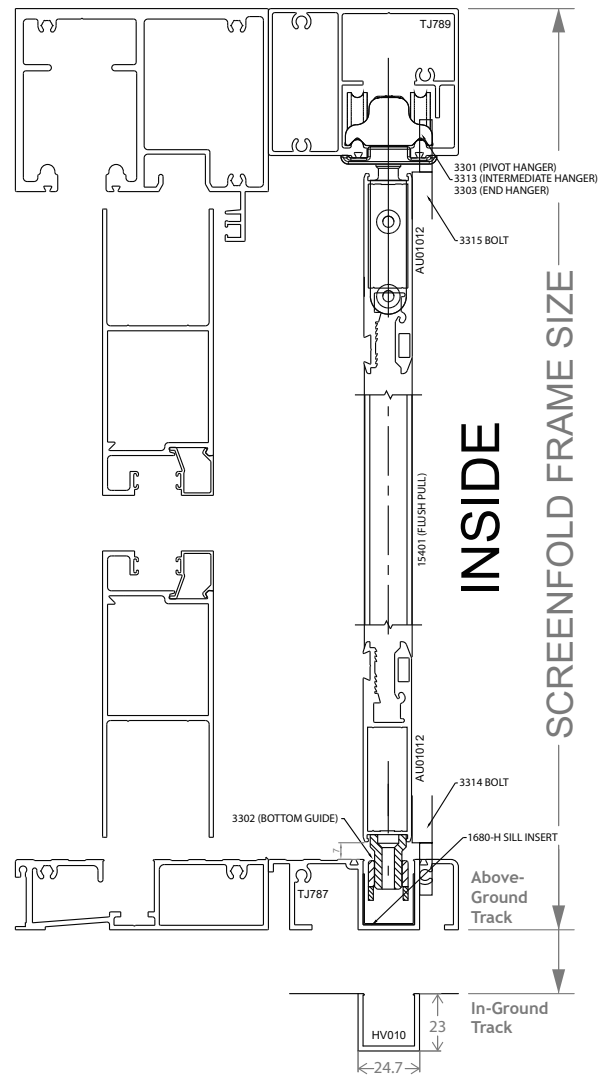
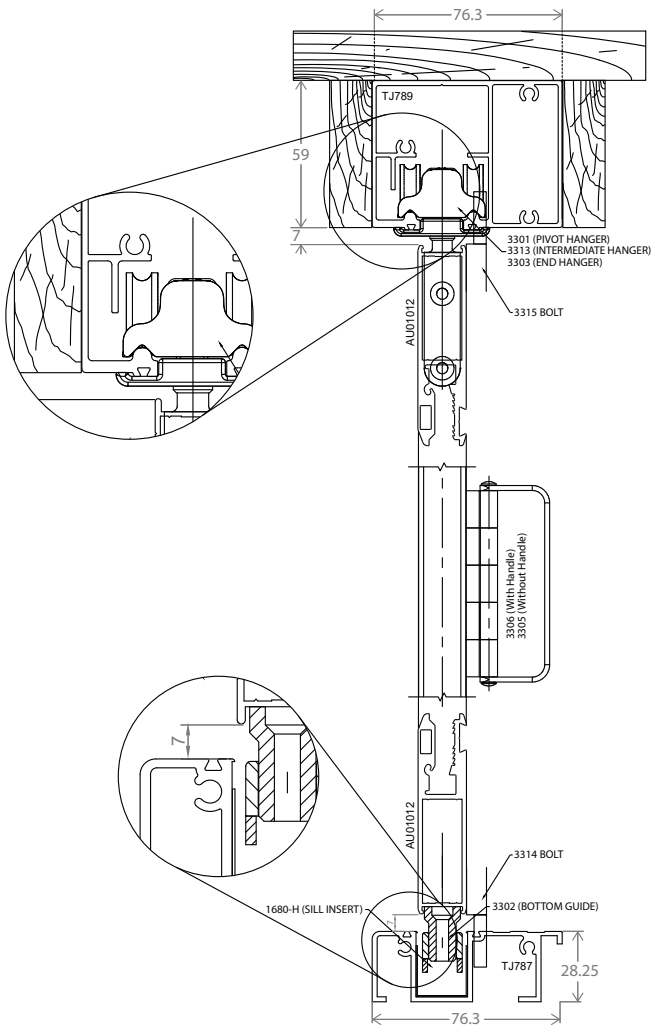

Can be flush with ground using HV010.  
Back lip of TJ787 can wrap over subsill front leg.

### Outward Screening Hardware

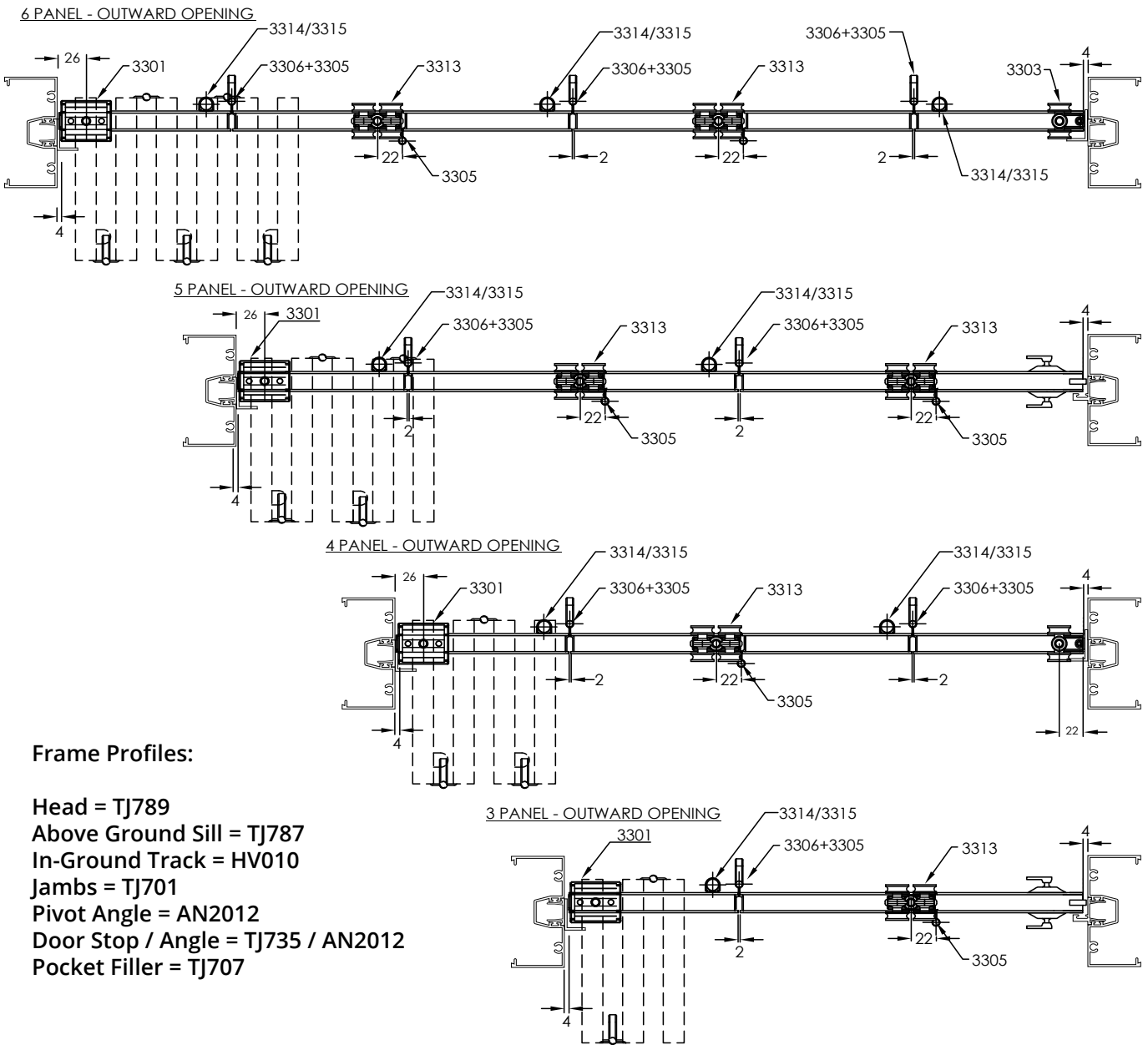

**Frame Profiles:**

- Head = TJ789
- Above Ground Sill = TJ787
- In-Ground Track = HV010
- Jambs = TJ701
- Pivot Angle = AN2012
- Door Stop / Angle = TJ735 / AN2012
- Pocket Filler = TJ707

Outward Screening Hardware													
Hardware Item	2 Panel Pivot	2+1 Panel Pivot	3 Panel Pivot	3+1 Panel Pivot	2+2 Panel	4 Panel Pivot	4+1 Panel Pivot	3+2 Panel Pivot	5 Panel Pivot	5+1 Panel Pivot	4+2 Panel Pivot	3+3 Panel Pivot	6 Panel Pivot
3301 Pivot Set	1	2	1	2	2	1	2	2	1	2	2	2	1
3305 Hinge	2	2	5	5	4	7	7	7	10	10	9	10	12
3306 Hinge (Handle)	1	1	1	1	2	2	2	2	2	2	3	2	3
3302 Bottom Guide	1	1	1	1	2	2	2	2	2	2	3	2	3
3303 End Hanger	1	1	-	-	2	1	1	1	-	-	2	-	1
3313 Intermediate Roller	-	-	1	1	-	1	1	1	2	2	1	2	2
3314 Latch (Bottom)	1	1	1	2	2	2	2	2	2	2	3	3	3
3315 Latch (Top)	1	1	1	2	2	2	2	2	2	2	3	3	3
1680-H PVC Channel	1	1	1	1	1	1	1	1	1	1	1	1	1

For Larger Configurations, Contact Darley For A Customised QTY.

### Inward Screening Hardware

Fabrication

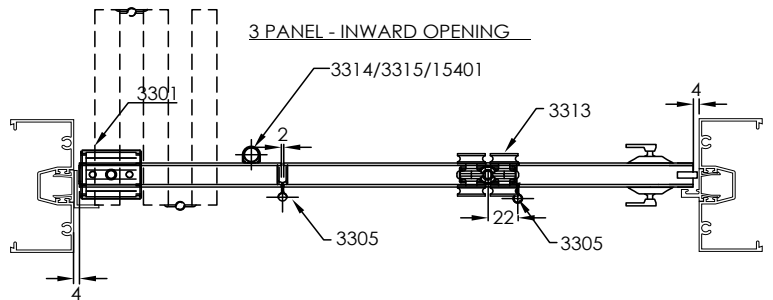
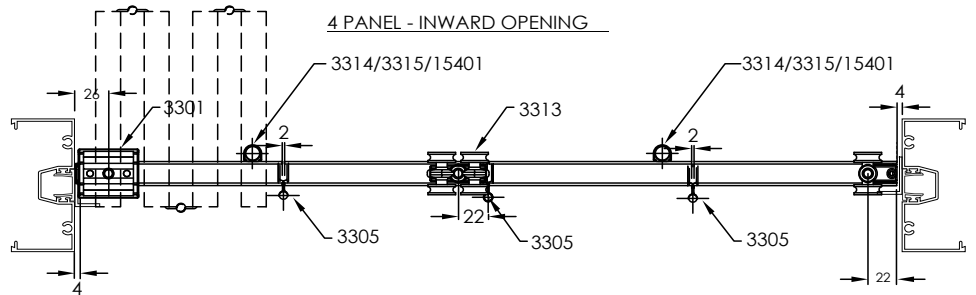
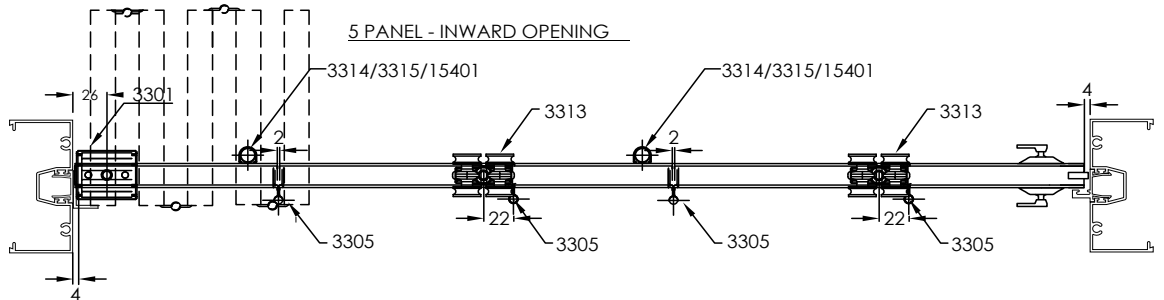
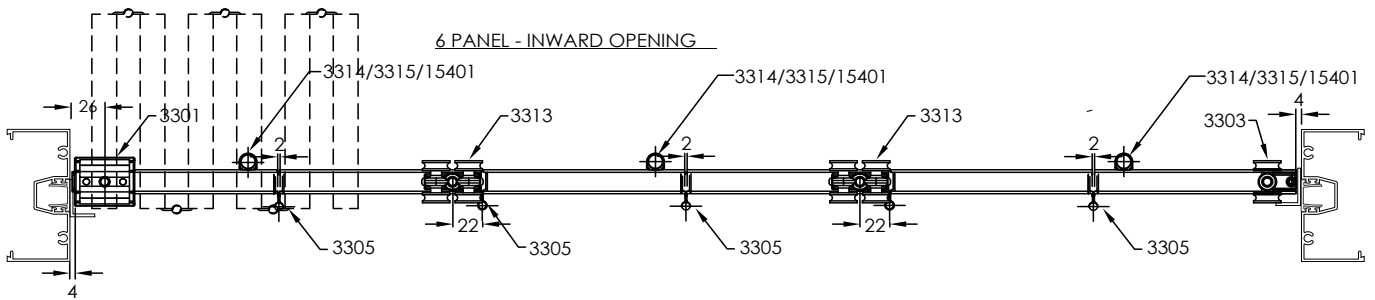

**Frame Profiles:**

- Head = TJ789
- Above Ground Sill = TJ787
- In-Ground Track = HV010
- Jambs = TJ701
- Pivot Angle = AN2012
- Door Stop / Angle = TJ735 / AN2012
- Pocket Filler = TJ707

Inward Screening Hardware													
Hardware Item	2 Panel Pivot	2+1 Panel Pivot	3 Panel Pivot	3+1 Panel Pivot	2+2 Panel	4 Panel Pivot	4+1 Panel Pivot	3+2 Panel Pivot	5 Panel Pivot	5+1 Panel Pivot	4+2 Panel Pivot	3+3 Panel Pivot	6 Panel Pivot
3301 Pivot Set	1	2	1	2	2	1	2	2	1	2	2	2	1
3305 Hinge	3	3	6	6	6	9	9	9	12	12	12	12	15
15401 Flush Pull	1	1	1	1	2	2	2	2	2	2	3	2	3
3302 Bottom Guide	1	1	1	1	2	2	2	2	2	2	3	2	3
3303 End Hanger	1	1	-	-	2	1	1	1	-	-	2	-	1
3313 Intermediate Roller	-	-	1	1	-	1	1	1	2	2	1	2	2
3314 Latch (Bottom)	1	1	1	2	2	2	2	2	2	2	3	3	3
3315 Latch (Top)	1	1	1	2	2	2	2	2	2	2	3	3	3
1680-H PVC Channel	1	1	1	1	1	1	1	1	1	1	1	1	1

For Larger Configurations, Contact Darley For A Customised QTY.

### Roller Access Machining Details

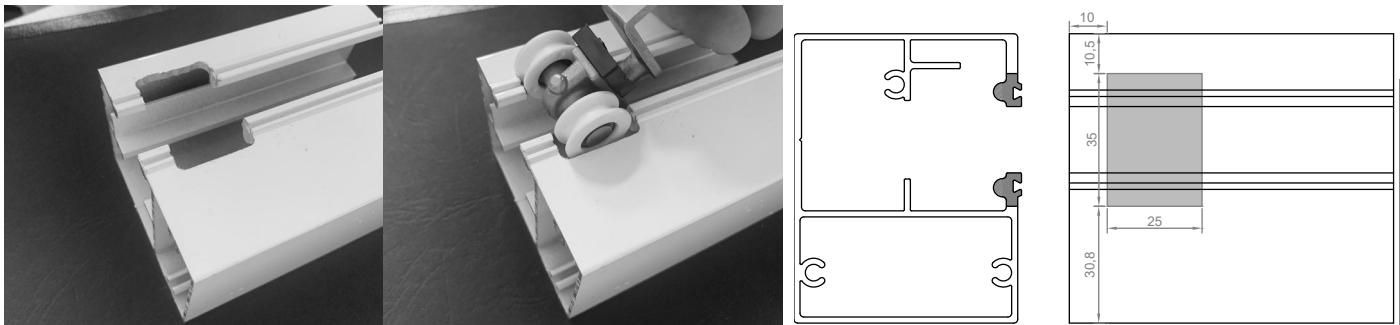

### 3314/3315 Bolt Machining Details

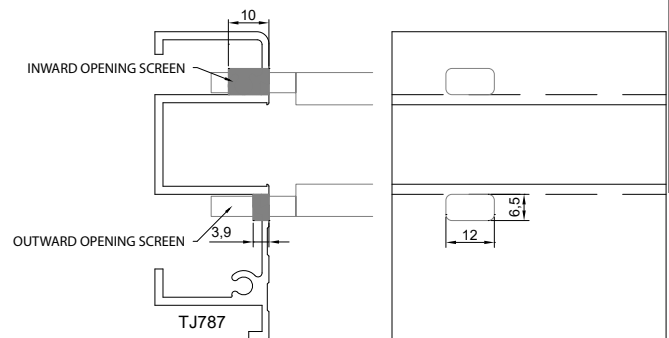
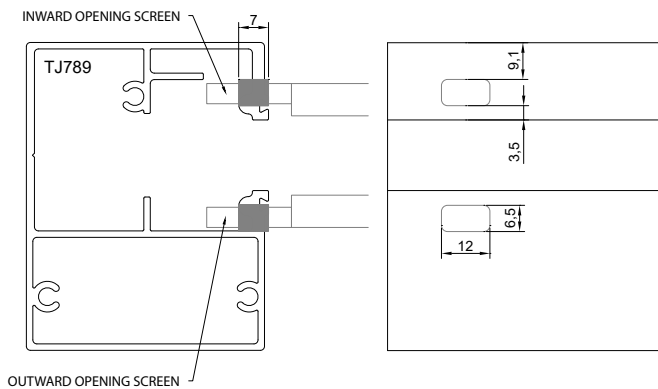

### Flush Pull (15401) Machining Details

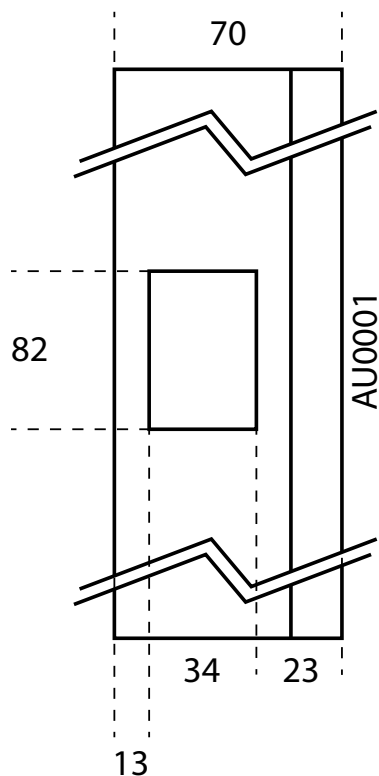

### 20x12 Angle (AN2012) Machining Details

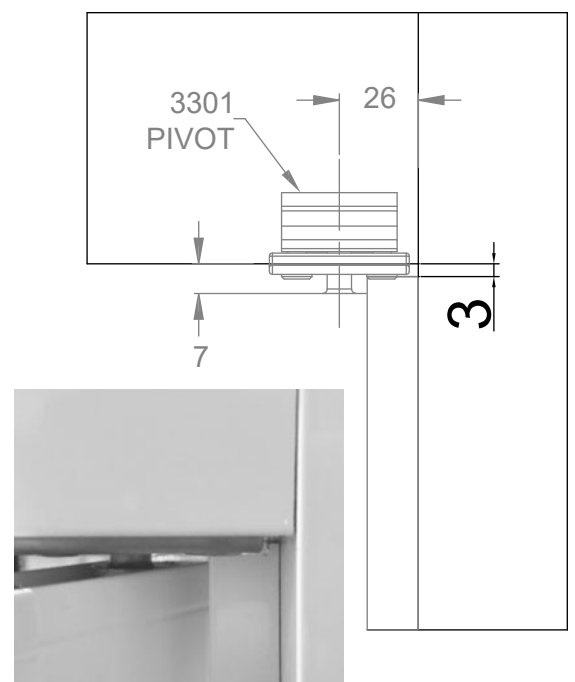

Pivot side angle AN2012 must stop 3mm short from head to clear pivot.

Fabrication

**Additional Tips**

1. If using reinforced nylon stakes, the bottom hole can double up as a fixing for both the roller brackets and the corner stake, helping to pull in the mitre joint.
2. To adjust panel tilt and alignment, unscrew top and bottom bracket which will allow access to wind up or down.
3. The black section of the roller should always face pivot side (acts as a stopper rather than damaging the wheel).
4. Preadjust the pivot appoximately ~5mm prior to attaching.
5. Bottom pivot should be mounted with the "open" side towards jamb.
6. AN2012 always used as pivot stop. TJ735 used on other jamb if last panel is hinged, otherwise use AN2012.
7. Consider your fixings - TJ705 frame flat filler is available to clip into jambs if necessary.

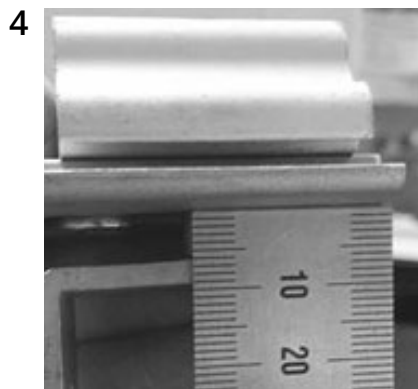

Ensure the mesh is supported with matting throughout the wedge process to prevent sagging as proper tensioning won't be possible after the wedge insertion. Use 7mm medium- to high-density foam is used to prevent compression under the weight. EVA75 foam is recommended.

## 2914 Tool Setup Details

### What you get:

Each kit contains the Corner Press, Multi Thickness Packers, Support Brackets and screws to complete the installation.

The unit is designed to be installed into the corner of your assembly bench.

### Specifications:

The machine is designed to crimp the corners of Security Window Frames to the Aluminium Corner Stakes.

Frame Thickness Range: 8 - 11 mm.

Important - The corner stake thickness should be a tight fit  
- maximum 1mm clearance.

The operating pressure is a minimum of 7 bar.

### Operating Instructions:

Attach thickness spacers under the anvil as needed:

- 11 mm frame: No spacers.
- 9 mm frame: Use 2 mm spacers.
- 8 mm frame: Use 3 mm spacers.

Insert the window frame corner with fitted corner stakes into the press.

Verify proper alignment of all parts.

Press the green button to activate the press.

Release the button and remove the frame (gently tap if it sticks).

Repeat for each corner

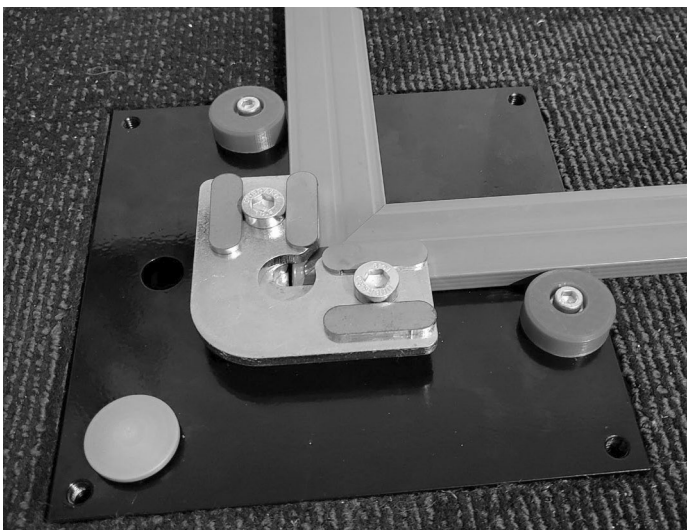

**1. Hole preparation**

Mark out a 192 x 192mm square on the left hand front corner.  
 Cut the hole through the bench top and carpet top.  
 Fit the support plates under the corners of the hole using the screw supplied.

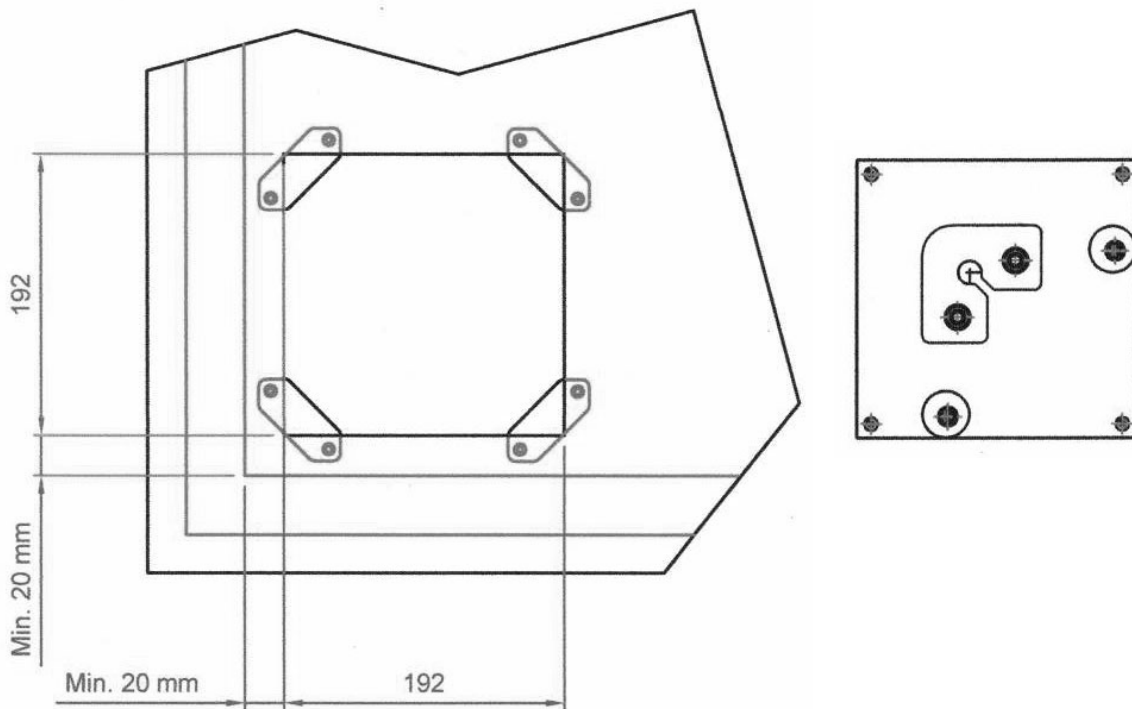

**1. Assembly of the Corner Press**

Place the press into the prepared hole.  
 Adjust the jacking screws to level the press with the bench surface.

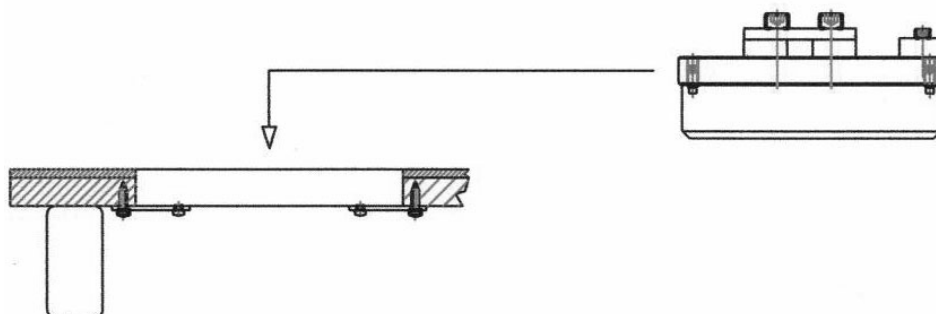

Fabrication

2914 Window Corner Crimper Details

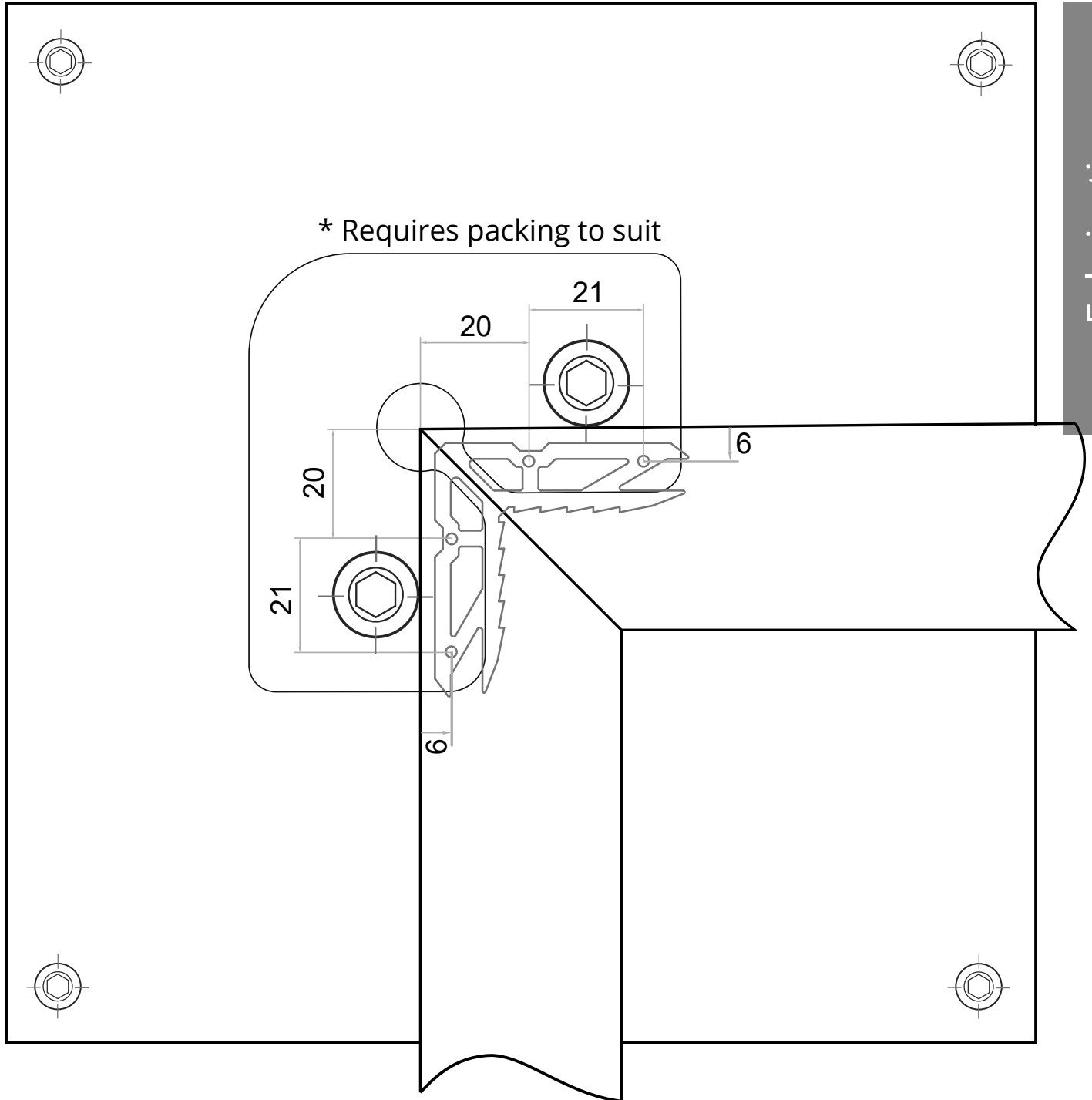

Fabrication

## 2916 Corner Stake Punch



### What You Get:

Each kit contains the portable Hole Punch, Foot Valve and the necessary tube and fittings. The operating pressure is a minimum of 7 bar.

### Installation Instructions

1. Place the corner press onto the bench or wall location.
2. Connect the tubing between the press and the foot valve.
3. Connect the air supply to the foot valve.

### Operating Instructions:

1. Slide the mitred end of the door section into the press - fully in against the stop.
2. Press the foot pedal to crimp the corner.
3. Release the foot pedal and remove the frame.

Follow the above procedure for each frame end

2910 Security Door Lock and Wheel Punch

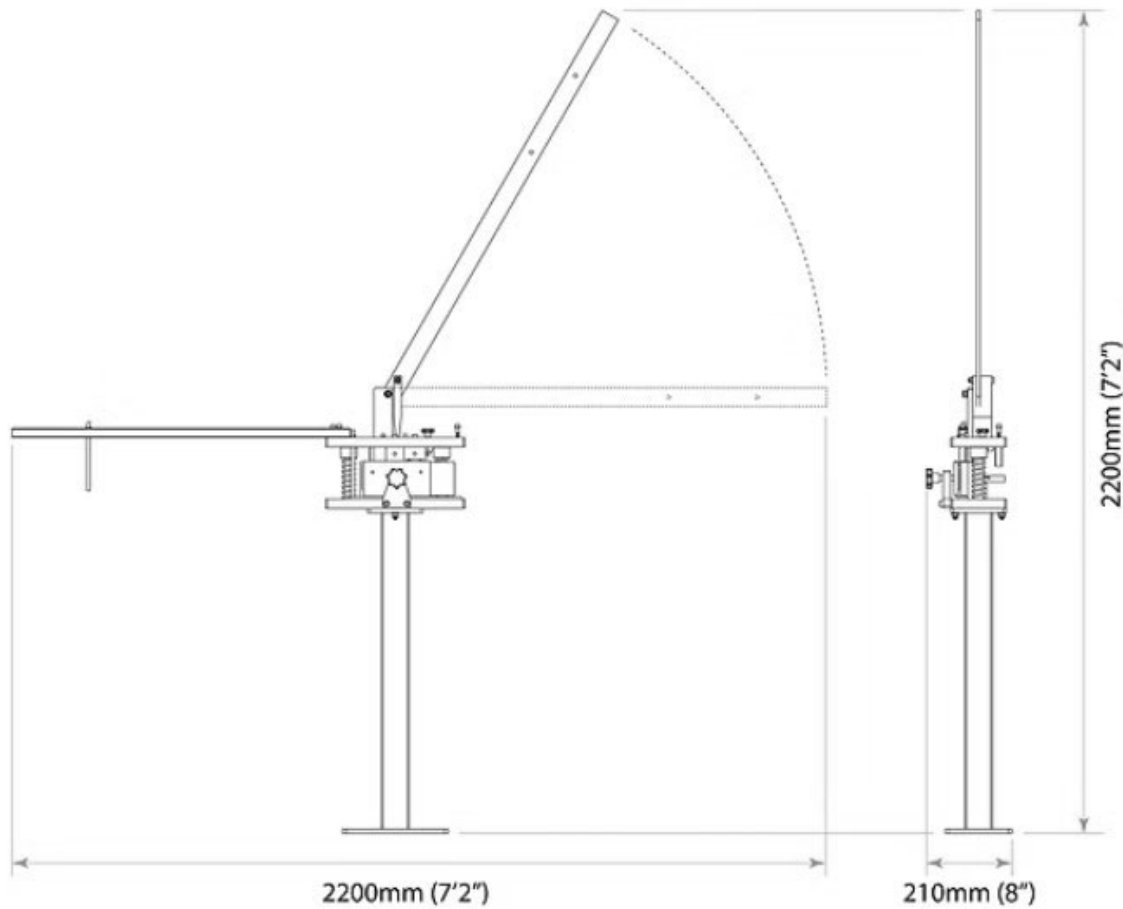

Fabrication

**PRODUCT SPECIFICATIONS**

- Operating Length: 2200mm\*
- Operating Width: 210mm
- Operating Height: 2200mm
- Weight: 50kg

This system installs security door locks into aluminium door frames. It creates mortise channels for common lock sizes, with two punches: one for the lock body and one for the escutcheon plates. The outrigger allows channels for three-point locks, and it can also make 46 mm cut-outs for sliding door roller wheels.

2915 Security Door Lock Site Tool

Fabrication

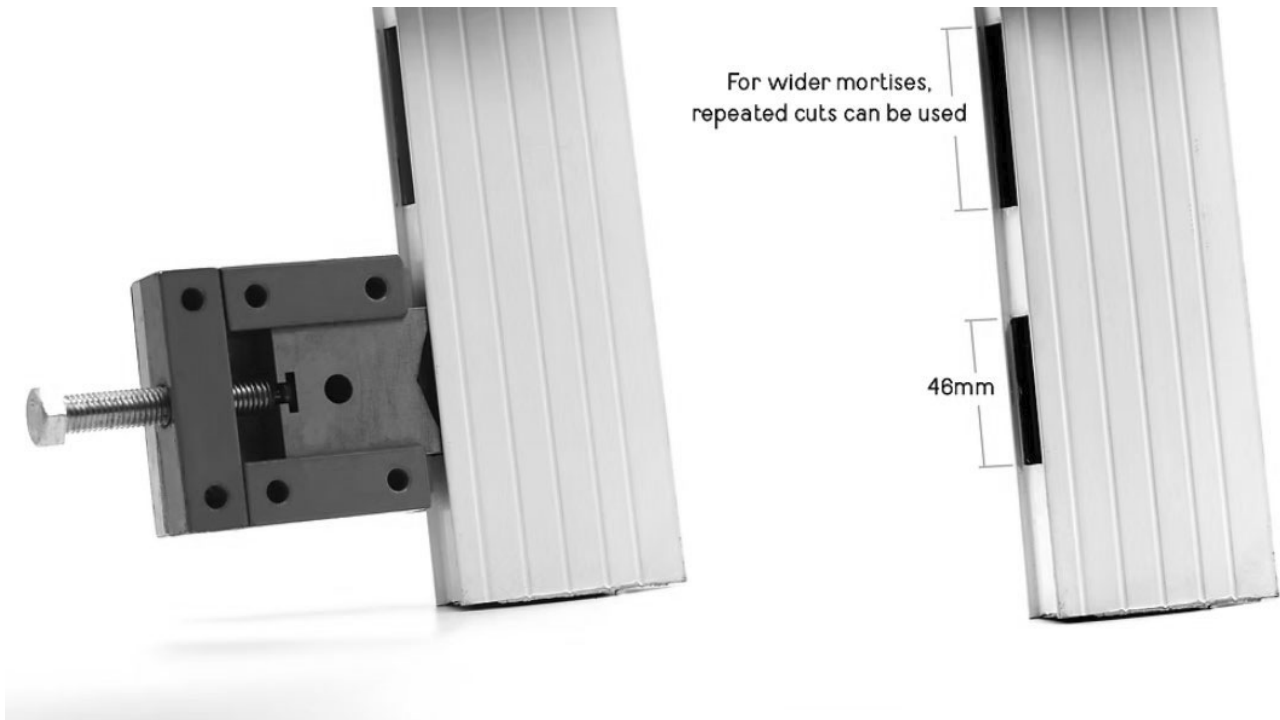

**PRODUCT SPECIFICATIONS**

Dimensions:

Length Fully Extended: 220mm

Length Fully Compressed: 170mm

Width: 80mm

Height: 34mm

Throat Capacity: 65mm

Stroke: 49mm

Weight: 1.25kg

The compact site tool allows installation of security door locks into existing door frames without the need to remove the door. The tool is mounted onto the door frame in the required position, and a 46mm sized mortise is created. Depending on the size of the door lock, the process is repeated along the slot until the desired size is achieved.

The hardened A2 steel punch is driven by an 18mm hex bolt, can be applied via an impact wrench or any standard spanner.



### 5.3 Profiles working



To avoid mistakes in the workings where there are adjustable stops, it is necessary to execute a preliminary working to check the correct position of the stops with the accessory which is used. Comall will be not responsible for possible modifications on the existing profiles or for the introduction of new profiles in the same system.

Fabrication

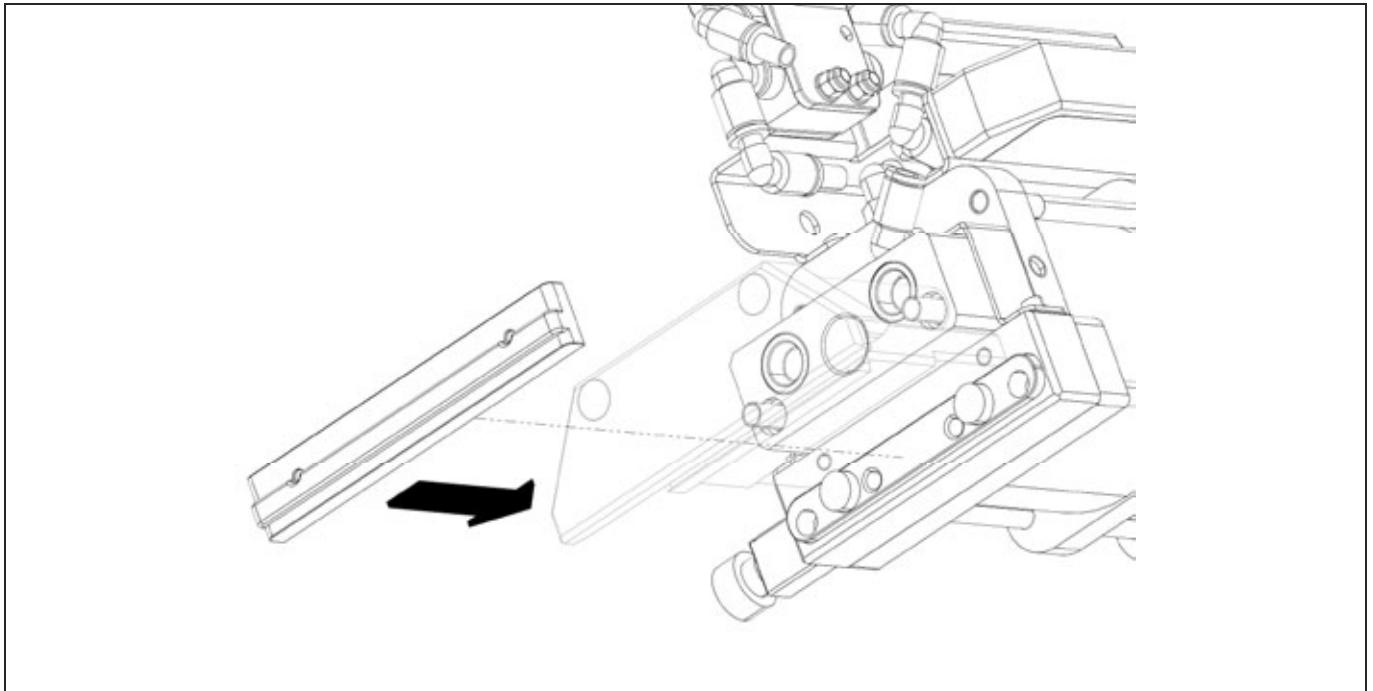

\* Clamp either side of the lock cutout to prevent distortion.

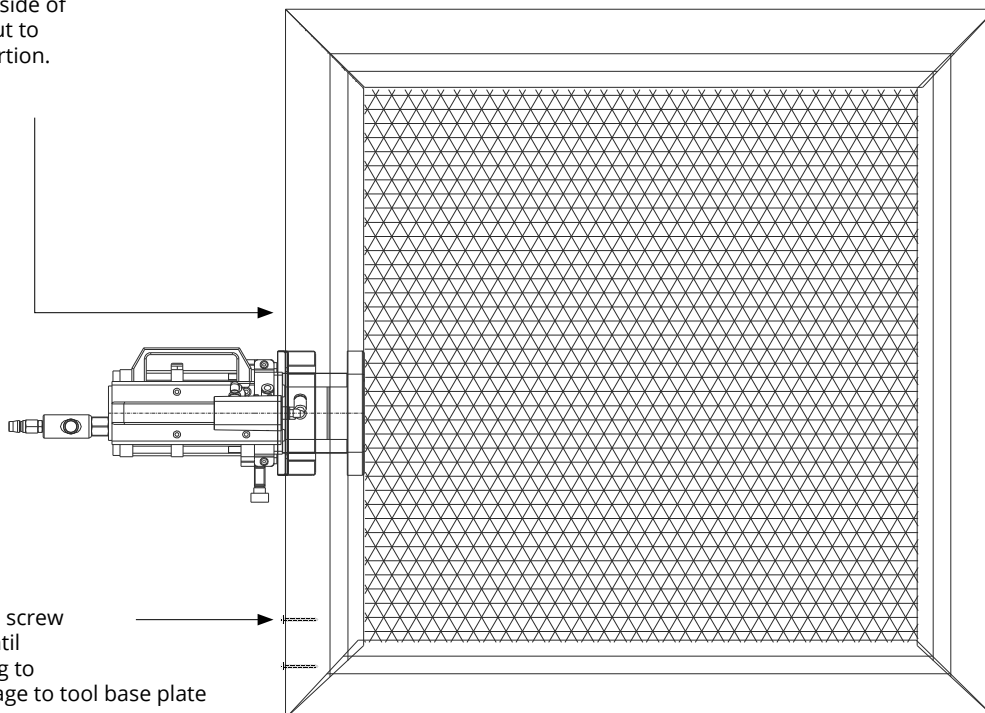

\* Leave second screw corner out until after clamping to prevent damage to tool base plate

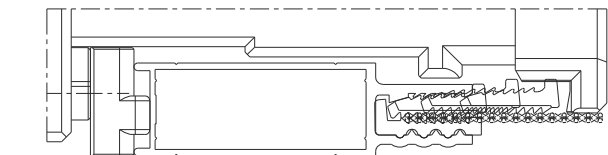
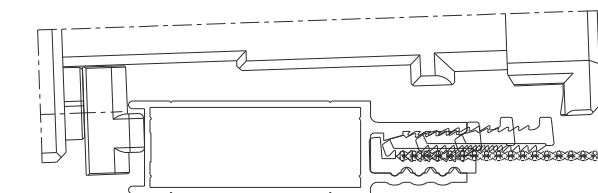
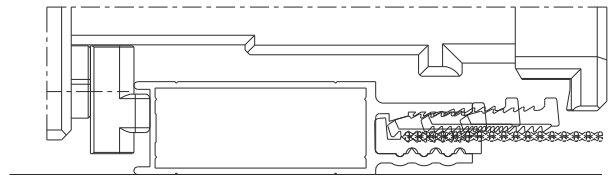
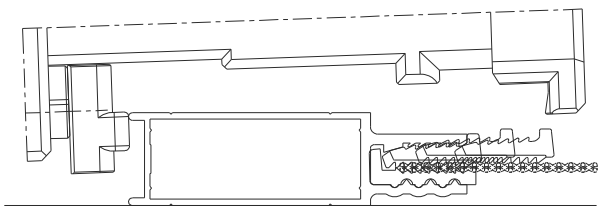
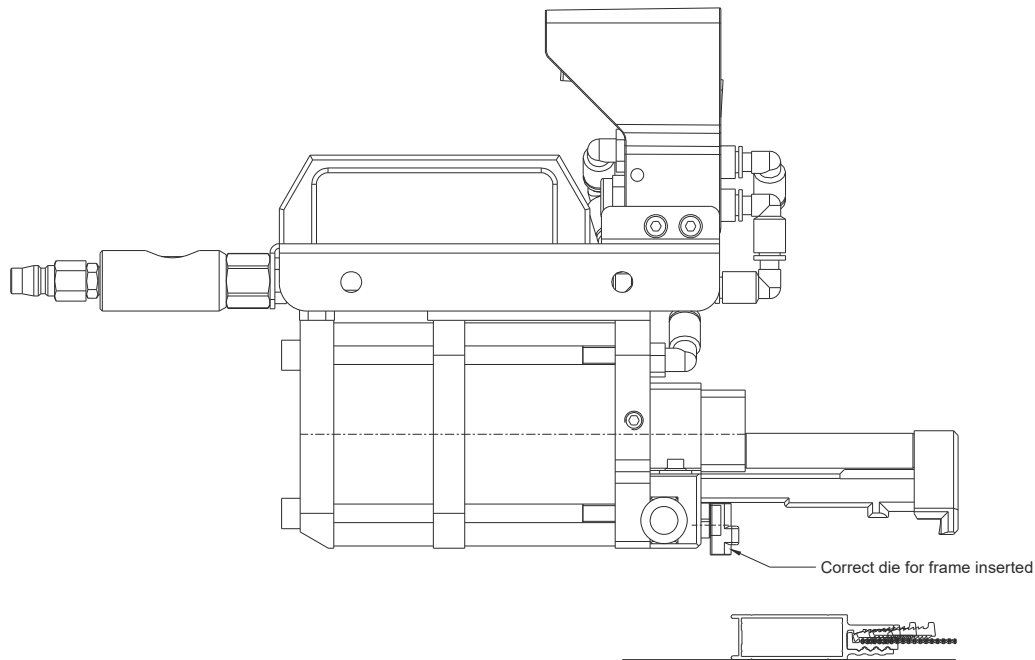

PHASE 1:

- Mount the profile support according to the profile to be worked.
- Set the frame on a plane surface, with the wedges upward.
- Insert the punching machine from above on the frame.
- Pull the knob toward the outside.

## 6.1 General maintenance

Fabrication

Lubricate dies and punches with oil spray or similar approximately every 25 machining operations (lubricate once a week anyway if the punching machine is not being used).		
Interval	Action	Personnel
Daily	Remove all machining residue from dies, work and contact surfaces (if necessary use a compressed air gun). <b>NEVER USE HANDS OR FINGERS</b>	Operator
Every week	Drain condensation from the air supply filter unit (if present).	Operator
Every week	Check the punches/knives and dies for wear and possible replacement.	Qualified personnel
Every month	Check and if necessary top up the oil tank on the filter unit (if present).	Operator
Every month	Clean out the compressed air intake filter (if present).	Operator

	The maintenance operations described below must be carried out by qualified personnel.
--	--

### 6.1.1 Tools and dies replacement

General rules to be followed when changing tools and dies.

Make sure there are no profiles or machining residue left in the insertion recesses before proceeding to change parts .

Move the machine to its end of travel in order to insert the tool into the die and disconnect the air supply, make sure the cylinder does not have enough energy to move it self, pushing the operating device (pedal and/or valve). Change the used components being careful to divide equally the backlash/play between the tool and die, check the condition of all the nuts and bolts and if necessary change any that require it.

Caution before to put in function again the machine, assure that:

all parts substituted and/or the tools used to carry out maintenance must have been removed from the insertion machine

any safety guards removed or open have been correctly replaced and fixed.

Switch on the air supply again, check for any leaks in the punching machine pneumatic circuit and carry out few empty cycles.

Repeat the empty cycle test using profile offcuts to check the calibrations.

### 6.1.2 Problems, causes and remedies

Problem	Cause	Remedy	Personnel
Insertion tool shows a lack of power	Valve and/or pedal damaged	Replace	Qualified
	Pneumatic cylinder seal worn	Replace worn seal.	Qualified
	Worn punches and dies	Replace worn parts and those that cannot be re-sharpened	Qualified (unless indicated otherwise in the chapter on spare parts)
	Insufficient or lack of air pressure	Check the air supply	Qualified

### 7.1 Mechanical spare parts

Station 1				
	Spare part list			
	Pos.	Code	Description	Q.ty
	1	MVX68336	Support	1
	2	MVX68337	Support	1
	3	MVX68094	Spring presser	1
4	MVX68333	Profile guide	1	

Fabrication

# STAINLESS STEEL SECURITY MESH SYSTEM

Protect your family and your view



## SCREENGUARD Stainless Steel Mesh Security System Warranty

Darley Aluminium Pty Ltd ACN 076 364 657 ("Darley") warrants to the purchaser ("Customer") of ScreenGuard components and products ("Products") from a Darley approved Screenguard door fabricator that the products purchased will be free from defects in material for a period of 10 years from the date of purchase ("Warranty Period"). This warranty is not transferable.

Darley's obligation under this Warranty, and subject to approval of the claim by Darley or their duly appointed representatives, is limited to repair or replace the component(s) deemed to be defective. If a replacement part is supplied, the Warranty Period remains based on the original date of purchase of the product by the Customer.

To make a warranty claim under this Warranty, the Customer must;

1. Inform Darley as soon as the warranty claim arises by contacting the security door fabricator that supplied and installed the Products ("Security Door Fabricator") within 30 days after the defect in the Product becomes apparent to explain the circumstances of your claim and to arrange a service call.
2. Provide the Security Door Fabricator / Darley with proof of purchase of the Product. The original sales receipt is your best proof of purchase.
3. The Security Door Fabricator / Darley will make its own evaluation of the fault stated by the Customer before any warranty claim is accepted and the Customer must provide reasonable opportunity for the Security Door Fabricator / Darley to inspect the Product after a warranty claim is made.

The application of this Warranty is subject to the following conditions;

1. The customer being registered with the Security Door Fabricator by completing and returning the detachable portion of this document supplied at the time of the installation;
2. The product being operated in accordance with the operating instructions;
3. The product being maintained in accordance with Darley`s preventative care and maintenance guide. Proof of maintenance and service must be demonstrated and provided on request.
4. The product must be fabricated and installed in accordance with the ScreenGuard Fabrication manual.

In addition to the above, this Warranty does not cover;

1. Extra charges such as travel and after hours call outs;
2. Fair wear and tear;
3. The correction of any non-Product fault or problem;
4. Any alteration to the Product in any way;
5. Damage or problems or unsatisfactory performance caused by non compliance by the Customer with Darley`s preventative care and maintenance guide or inappropriate cleaning of the Product;
6. Damage or problems or unsatisfactory performance caused by the use of an accessory, component or Product not supplied by Darley;
7. Damage or problems or unsatisfactory performance caused by storm, fire, flood, hail, atmospheric fall out, vandalism, misuse, negligence, Acts of God, earthquake, war, vermin, foreign matter entering the Product (e.g. dirt, sand, salt, moisture) or any other outside agency;
8. Damage caused by person other than Security Door Fabricator / Darley personnel while assessing the Product of any reason;
9. Any accessory item including any locks, handles, rollers, hinges and door closers supplied with the Product as these would be subject to warranty by the relevant manufacturer and supplier;
10. To the extent permissible by law, any incident or consequential damage (whether structural or otherwise) or failure due to accidental damage, impact, misuse, or negligence of any third party.

To the extent permitted by law, all costs of disposal, re-installation, cartage, freight, kilometre expenses, travel and insurance associated with this Warranty are to be paid by the claimant including all costs of Security Door Fabricator /Darley in attending to the assessment of the warranty claim where the defect is not covered by this Warranty.

SCREENGUARD.COM.AU

### SYDNEY HEAD OFFICE

8 Tyrone Pl, Erskine Park NSW 2759  
T: (02) 8887 2888

F: (02) 9834 3244

E: sales@darleyaluminium.com.au

### MELBOURNE

10 Bridge Rd, Keysborough VIC 3173  
T: (03) 9238 3888

F: (03) 9768 7288

E: salesvic@darleyaluminium.com.au

### BRISBANE

29 Access Ave, Yatala QLD 4207  
T: (07) 3287 1888

F: (07) 3287 2088

E: salesqld@darleyaluminium.com.au

### PERTH

36 Armstrong Rd, Hope Valley WA 6165  
T: (08) 9437 2999

F: (08) 9437 1024

E: saleswa@darleyaluminium.com.au

# STAINLESS STEEL SECURITY MESH SYSTEM

Protect your family and your view



The following statement applies if the supply of the Products to Customer sale as defined in the Australian Consumer Law. In this statement, 'Our' means Darley, 'goods' means; products' and 'you' means 'Customer';

*Our goods come with guarantees that cannot be excluded under the Australian Consumer Law. You are entitled to a replacement to refunds for a major failure and for compensation for any other foreseeable loss or damage. You are also entitled to have goods repaired or replaced if the goods fail to be of acceptable quality and the failure does not amount to a major failure.*

To the extent permitted by law, all other warranties whether implied or otherwise, not set out in these warranty terms and conditions are excluded and Darley is not liable in contract, tort (including without limitation, negligence or breach of statutory duty) or otherwise to compensate you for;

1. Any increased costs or expenses;
2. Any loss or profit, revenue, business, contracts or anticipated savings;
3. Any loss of expense resulting from a claim by a third party;
4. Any special, indirect or consequential loss or damage of any nature whatsoever caused by the Company's failure in complying with any obligations.

The benefits given to you in this Warranty are in addition to other rights and remedies under law in relation to the Products to which this Warranty applies.

This Warranty is not applicable outside Australia.

## Care & Maintenance Recommendations

Central within the ScreenGuard Security System is woven high tensile 316 grade stainless steel mesh and architectural aluminium framing. The woven design of the mesh in particular can attract impurities, salt and other contaminated particularly in corrosive and heavy industrial areas.

The ScreenGuard Security System will require regular maintenance to enhance its pristine appearance and prolong product life. Dependent upon the proximity from coastal beachfront, tidal waters and heavy industrial areas will determine the cleaning frequency.

PowaWash is a biodegradable. Environmentally friendly, tired and proven washing formula. Mix three caps of Powawash with every litre of water. It is recommended to use a soft bristled brush or non-abrasive cloth with Powawash or warm potable water and neutral detergent, then rinse with potable water. Abrasive cleaners and harsh detergents are not recommended as these can scratch or damage the surface area.

**Failure to comply with this cleaning schedule will void the ScreenGuard Extreme 10 year Warranty.**

ENVIRONMENT	DEFINITION	FREQUENCY
Mild	15km from coastal / rural / suburban areas	Every 6 months
Moderate	10km from coastal / high traffic areas	Every 3 months
Severe / Coastal	5km from coastal / marine / heavy industrial areas	Every 2 weeks



## ScreenGuard PowaWash Concentrate

Mix 3 caps (25mls) per litre of water. It is recommended to use a soft bristled brush or non-abrasive cloth with Powawash or warm potable water and neutral detergent, then rinse with potable water. Abrasive cleaners and harsh detergents are not recommended as these can scratch or damage the surface area. Powawash is non-toxic, biodegradable and environmentally friendly.

## ScreenGuard Product Registration

To register your ScreenGuard product, please go to *Product Registration* section of the ScreenGuard website: <https://screenguard.com.au/>

SCREENGUARD.COM.AU

### SYDNEY HEAD OFFICE

8 Tyrone Pl, Erskine Park NSW 2759  
T: (02) 8887 2888

F: (02) 9834 3244

E: sales@darleyaluminium.com.au

### MELBOURNE

10 Bridge Rd, Keysborough VIC 3173  
T: (03) 9238 3888

F: (03) 9768 7288

E: salesvic@darleyaluminium.com.au

### BRISBANE

29 Access Ave, Yatala QLD 4207  
T: (07) 3287 1888

F: (07) 3287 2088

E: salesqld@darleyaluminium.com.au

### PERTH

36 Armstrong Rd, Hope Valley WA 6165  
T: (08) 9437 2999

F: (08) 9437 1024

E: saleswa@darleyaluminium.com.au



## Release Notes

Darley Aluminium  
SCRENGUARD SECURITY SYSTEM

### 1. Technical Manual Release Notes

This page is intended to record all changes to the **SCRENGUARD SECURITY EXTREME SYSTEM** technical manual pages.

Changes or additions to this manual will be itemised with a brief description and date when the amendments were made. It is important that a copy of the page be issued with the update and inserted as the first page in the customers technical manual.

ISSUE	DATE	DESCRIPTION OF CHANGE	REFER TO SECTION
1.0	May 2026	Mesh Thickness adjusted to Strand Thickness	Page 19, 26

