

50mm Hook Awning System



SLS - 4000 Pa
ULS - 5000 Pa



Air - 0.85L
Water - 800 Pa



Acoustic - Rw 41
6/10/10.5mm Laminate



Fire Rating
Tested - BAL 40



Single glazed
U VALUE 5.81 to 6.77
SHGC 0.24 to 0.49
TVW 0.1 to 0.46

Double glazed
U VALUE 4.24 to 4.96
SHGC 0.14 to 0.45
TVW 0.17 to 0.43

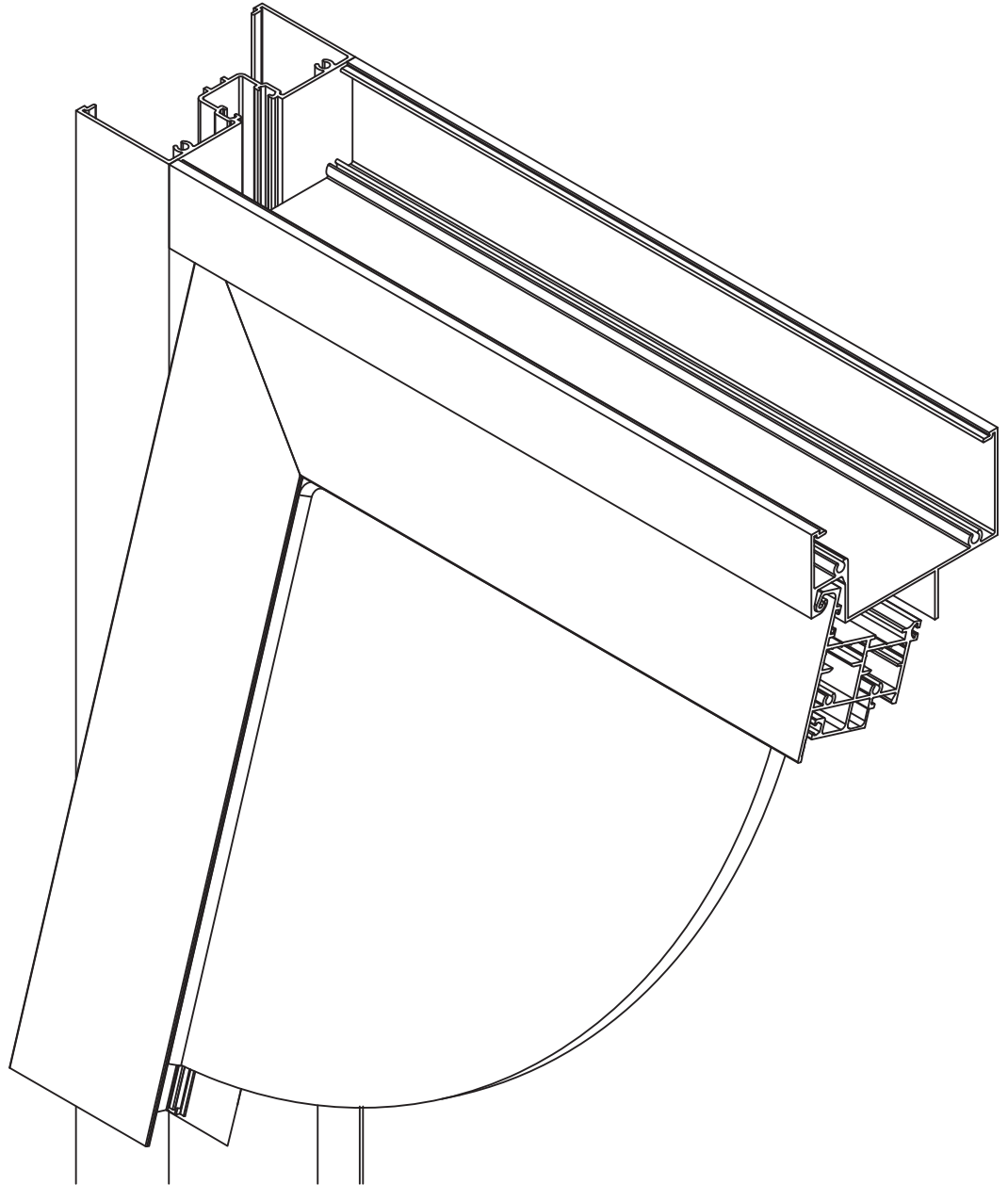

53mm
76mm
100mm
150mm
165mm
200mm
250mm

DEC 2025 | Version 1.1



U-Value 3.1 - 6.2
Max 30mm

Subsill & Sump
Draining

Transom
Draining



Disclaimer

Darley Aluminium strives to ensure the technical details contained in this manual are complete and correct. Occasionally, some errors or outdated information may require rectification - Darley Aluminium takes no responsibility for any loss or damage as a result of these errors. If you are unsure of any information provided within this manual, please contact your nearest Darley Aluminium office.

Engineering, manufacture and installation of frames must meet requirements of AS2047 (Windows in Buildings).

Glazing selected must meet requirements of AS 1288 (Glass in Buildings).

Size limitations are governed by design intent, glass selection, and local wind load requirements as per AS/NZS 1170.2 (Wind Actions) or AS 4055 (Wind Loads for Housing). An Engineer should be consulted to ensure selected framing and installation meets the requirements as set out by the relevant Australian Standards.

Any reference to an Australian Standard within this manual is based on the interpretations of Darley Aluminium. Code Compliance responsibility remains with the user of this manual. Misuse or misinterpretation of the information in this manual or of the Australian Standards remains the responsibility of the user of this manual.

Engineering, manufacture and installation must meet requirements of AS 2047, AS3959, WERS and Acoustic requirements. Glazing selected must meet requirements of AS 1288. Size limitations are governed by design intent, glass selection, and local wind load requirements as per AS/NZS 1170.2 or AS 4055.

N.B.- For frames, designs, and configurations outside the tested scope, an engineer or suitably qualified person should be consulted.

Copyright

This technical manual and the information within remains the property of Darley Aluminium. The manual must not be reproduced, copied or loaned without prior agreements with Darley Aluminium.

Contents

Introduction	5
Welcome	5
Overview.....	5
Design Features.....	5
Performance Summary	5
System Requirements.....	5
1:1 Section Profiles	6
Hardware	17
Performance	23
Performance Summary	23
Configuration Performance	24
Test Results	25
Acoustic Test Report	35
BAL Compliance	37
Glazing	38
Glass & Rubber Combinations	38
Energy Ratings	39
Fabrication	42
General Configuration	43
Hardware Options.....	61
Electric Chainwinder Box.....	75
ROTO Locking Options.....	76
Hardware Accessories	77
Awning Hardware.....	78
Component Assembly	80
Machining	83
Cutting Formula.....	83
Striker Placement.....	95
100mm Subframe Details	96
150mm Subframe Details	104
Tooling	112
Appendix	115
Maintenance & Warranty	115
Release Notes	117

Welcome

Overview

Darley's Universal Awning Window System is the ideal choice for modern architectural requirements, meeting current design trends as well as high performance specifications. The system is ideally suited for shopping centres, offices, show rooms, high-rise and commercial buildings. Framing options include 100/101.6/150mm Front and Centre Glazed combinations, with a range of stop options to suit, while sash options include hook, chainwinder, cams or multipoint. Glazing ranging from 6mm to 30mm can be installed with various beads to suit. All Darley framing systems are available in powder coat and anodise finishes, or mill finish. (Refer to Darley Aluminium Product Catalogue for further information.)

Design Features

- Accepts glass thickness from 6mm to 30mm.
- Compatible with other Darley Aluminium Commercial and Residential Systems
- Self-draining transom
- Non-recessed or recessed sash-stops available
- Hook, chainwinders, cams and multipoint hardware available
- Range of heavy duty mullion options for tall framing and high wind areas
- Max Sash Weight = 70kg
- Tested and Approved by an independent NATA accredited laboratory
 - AS2047
 - AS4284 (Water Gusting)

Performance Summary

Performance Summary							
Sash Size	SLS	ULS	Water	Air Infiltration	Acoustic	BAL	Glass
3490 x 1850mm Ratings Listed	4000pa	5000pa	2300	0.85L/s m ²	41 Rw	Bal40	Max 30mm

System Requirements

- Engineering, manufacture and installation of frames must meet requirements of:
 - AS2047-2048 (Windows and External Glazed Doors in Buildings)
- Glazing selected must meet requirements of AS1288 (Glass in Buildings - Selection and Installation)

Sash Profiles

Scale 1:1

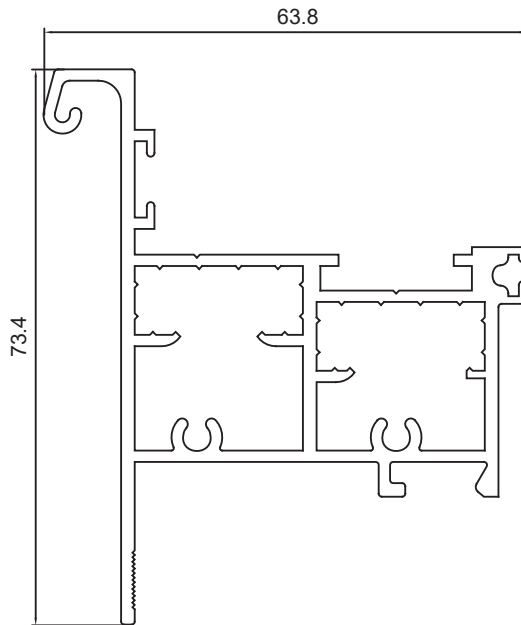
**TJ747**

Awning Sash

$$I_{xx} = 140.1 \times 10^3 \text{ mm}^4$$

$$I_{yy} = 189.7 \times 10^3 \text{ mm}^4$$

A.P. = 369 mm

P.P. = 278 mm

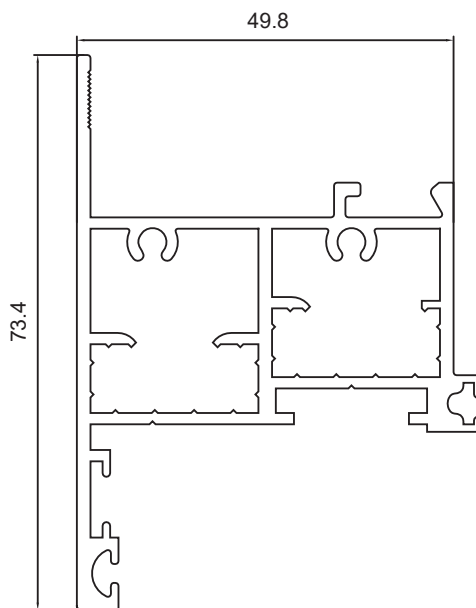
**TJ742**

Awning Sash

$$I_{xx} = 122 \times 10^3 \text{ mm}^4$$

$$I_{yy} = 170.4 \times 10^3 \text{ mm}^4$$

A.P. = 345 mm

P.P. = 254 mm

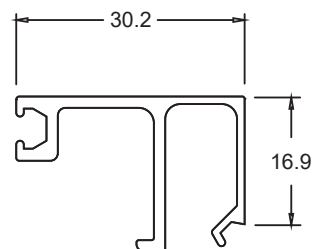
**TJ714**

6-12mm Sash Bead

A.P. = 167 mm

P.P. = 100 mm

Mainframe Profiles

Scale 1:1

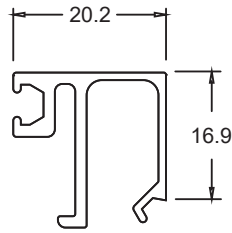

TJ716

16-22mm Sash Bead

A.P. = 147 mm
P.P. = 100 mm

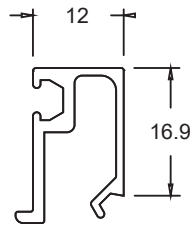

TJ717

24-30mm Sash Bead

A.P. = 118 mm
P.P. = 100 mm

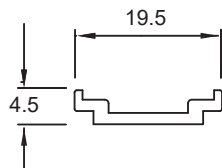

CGM001

Stay Packer

A.P. = 100 mm
P.P. = - mm

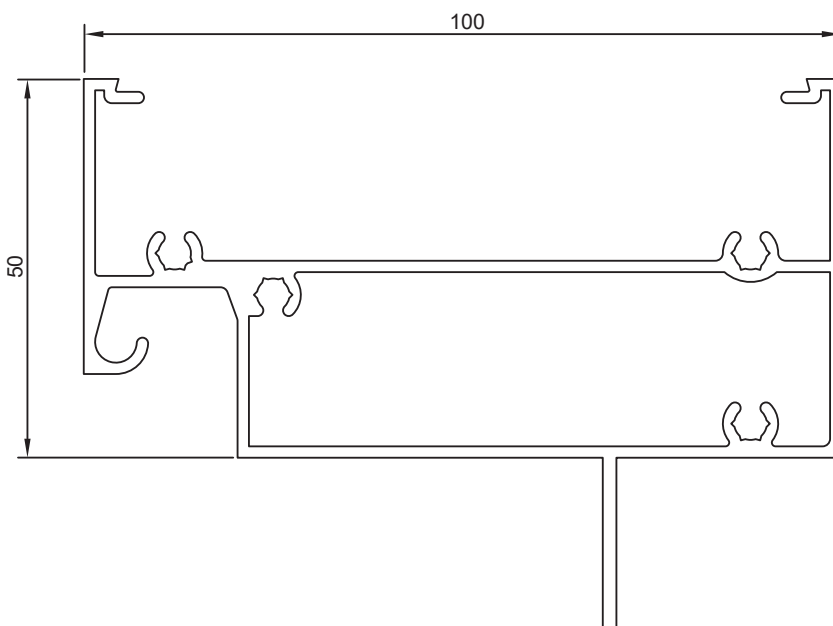

CSG728

Awning Head/
Transom/ Sill

$I_{xx} = 146.3 \times 10^3 \text{ mm}^4$
 $I_{yy} = 733.5 \times 10^3 \text{ mm}^4$

A.P. = 494 mm
P.P. = 236 mm

Mainframe Profiles

Scale 1:1

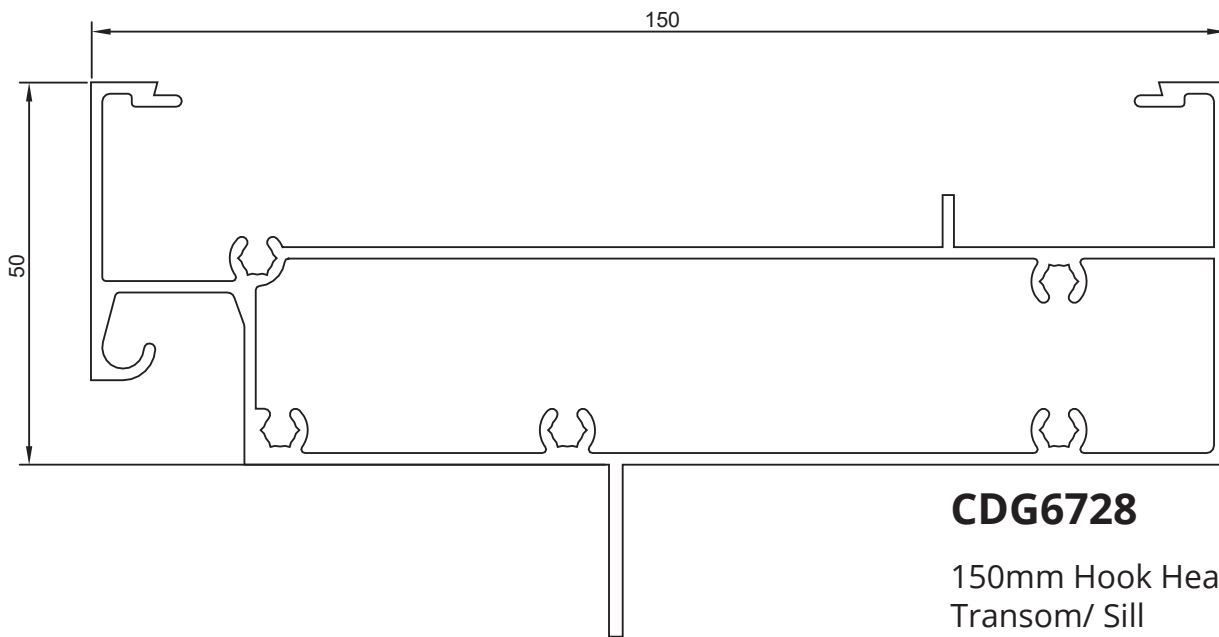
**CDG6728**

150mm Hook Head/
Transom/ Sill

$$I_{xx} = 197.2 \times 10^3 \text{ mm}^4$$

$$I_{yy} = 1936.9 \times 10^3 \text{ mm}^4$$

A.P. = 606 mm
P.P. = 295 mm

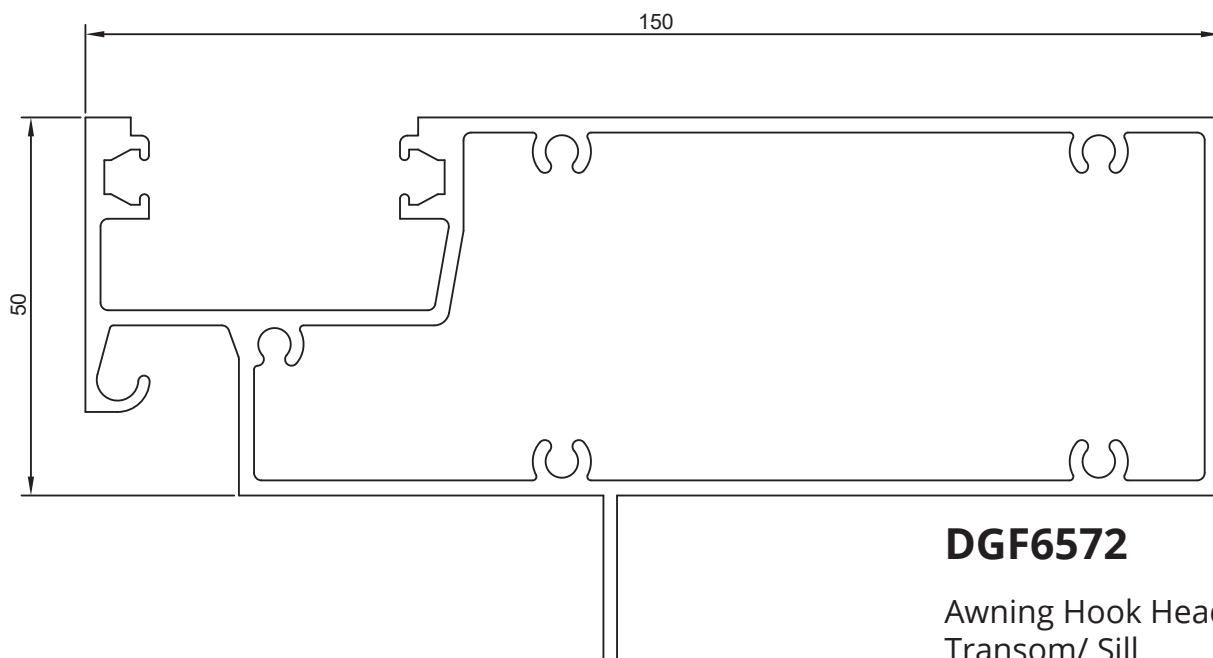
**DGF6572**

Awning Hook Head/
Transom/ Sill

$$I_{xx} = 437.2 \times 10^3 \text{ mm}^4$$

$$I_{yy} = 2541.9 \times 10^3 \text{ mm}^4$$

A.P. = 582 mm
P.P. = 390 mm

Mainframe Profiles

Scale 1:1

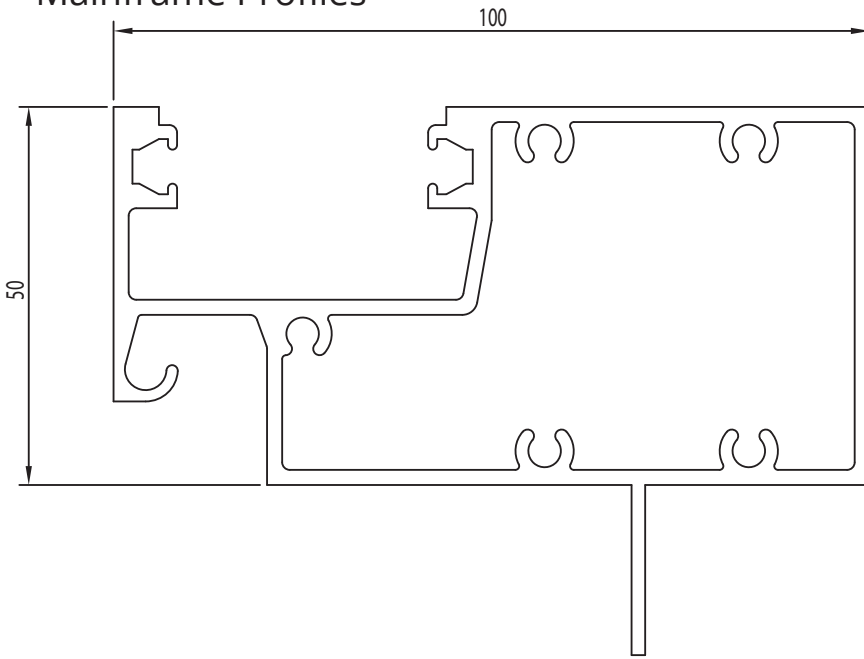

DGF4573

Awning Head/
Transom/ Sill

$$I_{xx} = 321.7 \times 10^3 \text{ mm}^4$$

$$I_{yy} = 906.2 \times 10^3 \text{ mm}^4$$

A.P. = 482 mm

P.P. = 289 mm

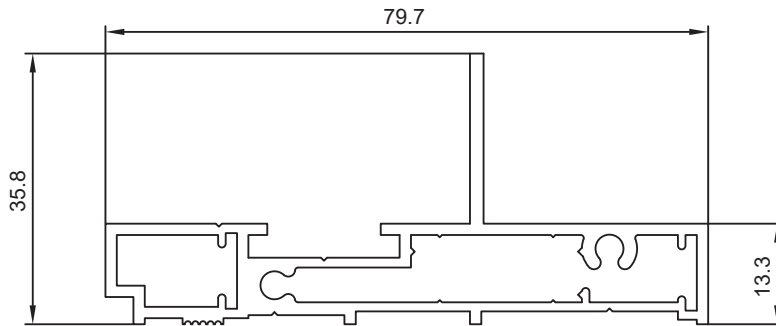

TJ748

Awning Recessed Stop

$$I_{xx} = 19.6 \times 10^3 \text{ mm}^4$$

$$I_{yy} = 205.8 \times 10^3 \text{ mm}^4$$

A.P. = 264 mm

P.P. = 174 mm

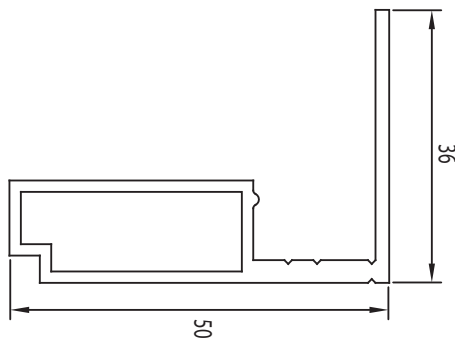

TJ749

Awning Sash Stop

$$I_{xx} = 19.1 \times 10^3 \text{ mm}^4$$

$$I_{yy} = 68.9 \times 10^3 \text{ mm}^4$$

A.P. = 194 mm

P.P. = 194 mm

Mainframe Profiles

Scale 1:1

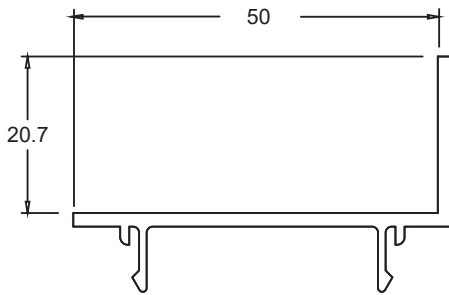
**DGF4519**

Awning Stop

$$I_{xx} = 6.10 \times 10^3 \text{ mm}^4$$

$$I_{yy} = 16.84 \times 10^3 \text{ mm}^4$$

A.P. = 187 mm
P.P. = 100 mm

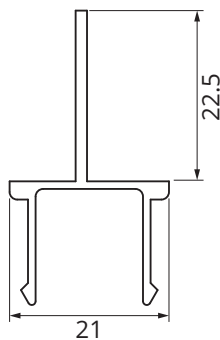
**CSG715**

50mm Awning Stop

$$I_{xx} = 4.7 \times 10^3 \text{ mm}^4$$

$$I_{yy} = 16.5 \times 10^3 \text{ mm}^4$$

A.P. = 145 mm
P.P. = - mm

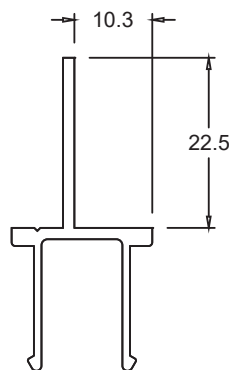
**TJ715**

Awning Stop

$$I_{xx} = 1.85 \times 10^3 \text{ mm}^4$$

$$I_{yy} = 7.10 \times 10^3 \text{ mm}^4$$

A.P. = 208 mm
P.P. = 100 mm

Mainframe Profiles

Scale 1:1

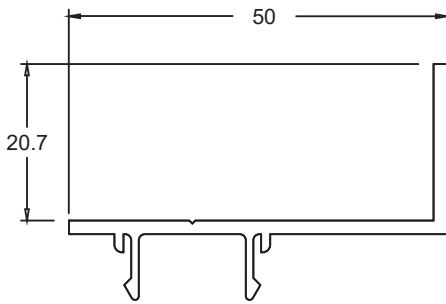

FGS419

Awning Stop

$$I_{xx} = 8.23 \times 10^3 \text{ mm}^4$$

$$I_{yy} = 18.67 \times 10^3 \text{ mm}^4$$

A.P. = 160 mm
P.P. = 100 mm

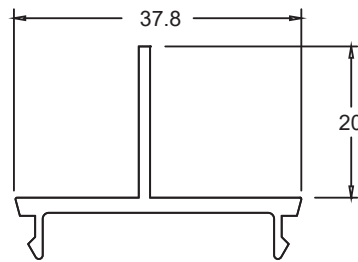

CDG4319

Awning Stop

$$I_{xx} = 4.10 \times 10^3 \text{ mm}^4$$

$$I_{yy} = 19.22 \times 10^3 \text{ mm}^4$$

A.P. = 143 mm
P.P. = 100 mm

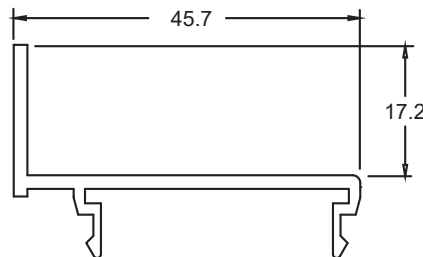

CDG6519

Awning Stop

$$I_{xx} = - \times 10^3 \text{ mm}^4$$

$$I_{yy} = - \times 10^3 \text{ mm}^4$$

A.P. = 175 mm
P.P. = 100 mm

Mainframe Profiles

Scale 1:1

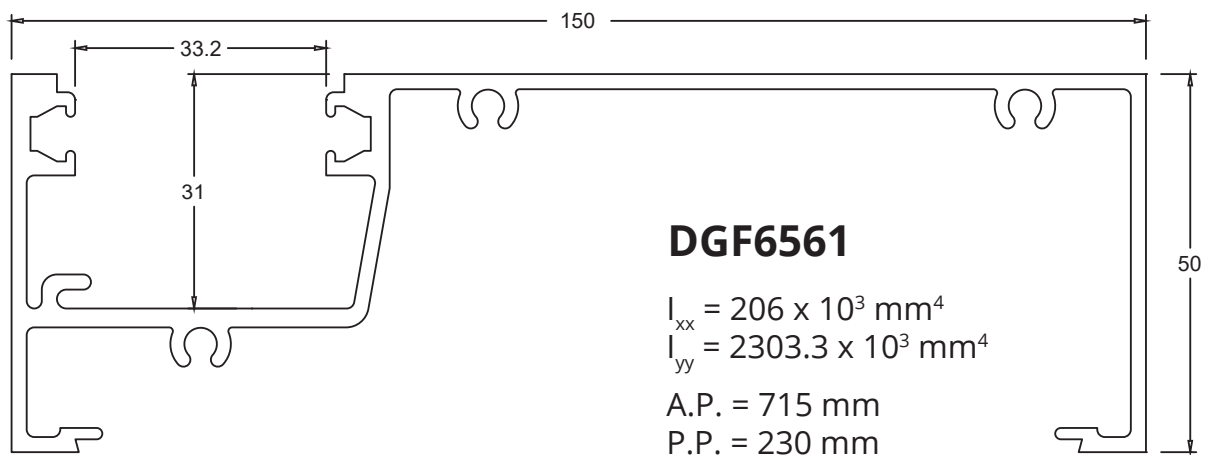
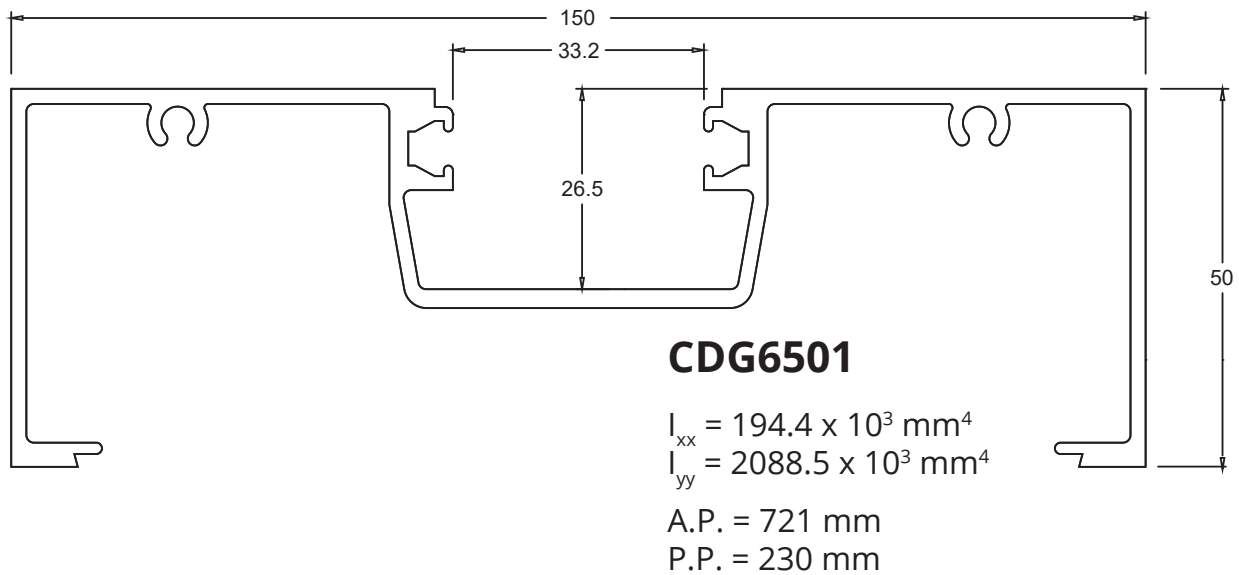
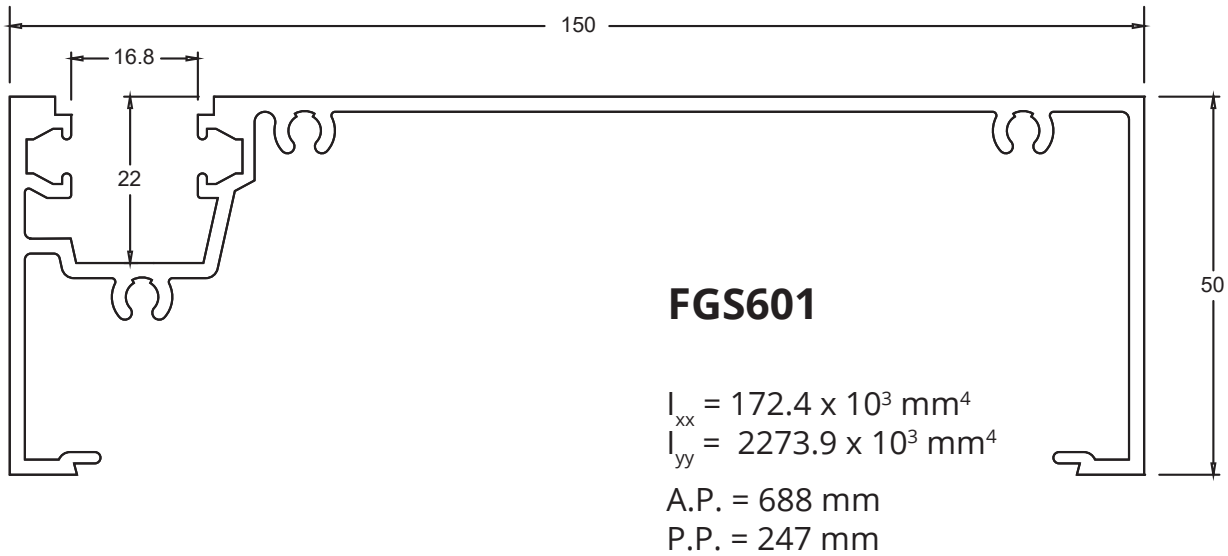

Mainframe Profiles

Scale 1:1

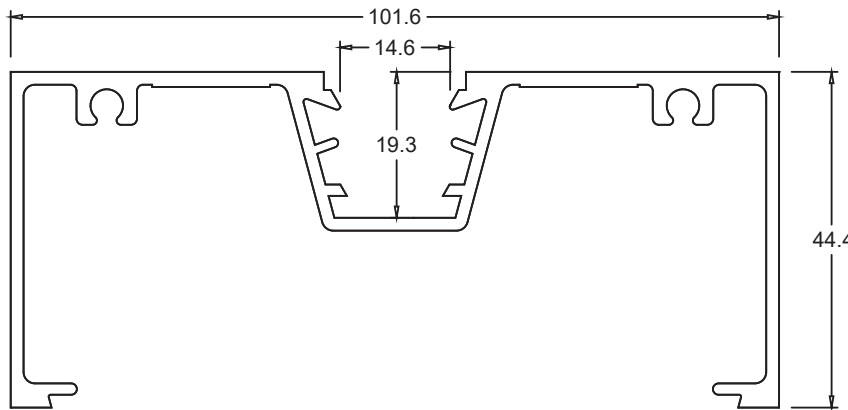

TJ301

Standard Main Frame

$I_{xx} = 98.29 \times 10^3 \text{ mm}^4$
 $I_{yy} = 677.94 \times 10^3 \text{ mm}^4$
 A.P. = 541 mm
 P.P. = - mm

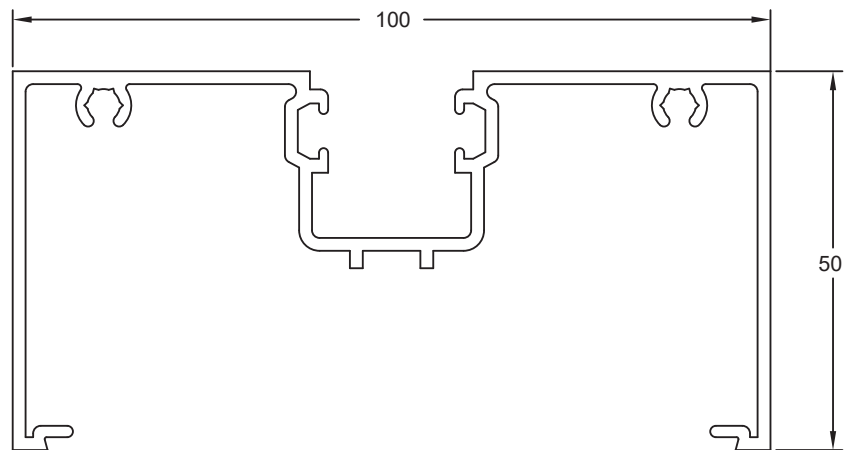

CSG301

Standard Mainframe

$I_{xx} = 117 \times 10^3 \text{ mm}^4$
 $I_{yy} = 658.8 \times 10^3 \text{ mm}^4$
 A.P. = 594 mm
 P.P. = 188 mm

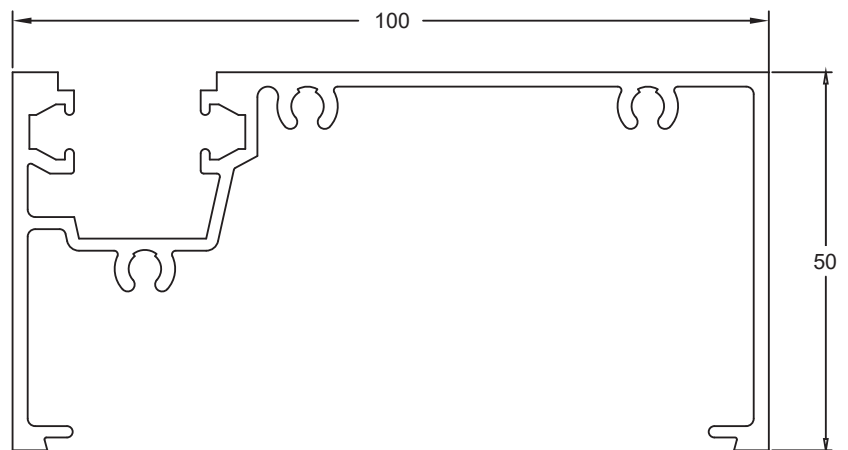

FGS401

$I_{xx} = 148.8 \times 10^3 \text{ mm}^4$
 $I_{yy} = 835.4 \times 10^3 \text{ mm}^4$
 A.P. = 589 mm
 P.P. = 198 mm

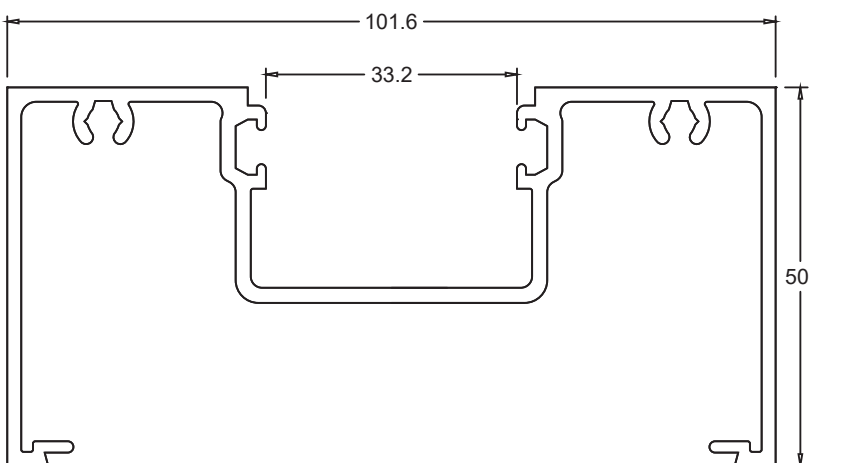

CDG4301

$I_{xx} = 148.8 \times 10^3 \text{ mm}^4$
 $I_{yy} = 880.4 \times 10^3 \text{ mm}^4$
 A.P. = 611 mm
 P.P. = 174 mm

Mainframe Profiles

Scale 1:1

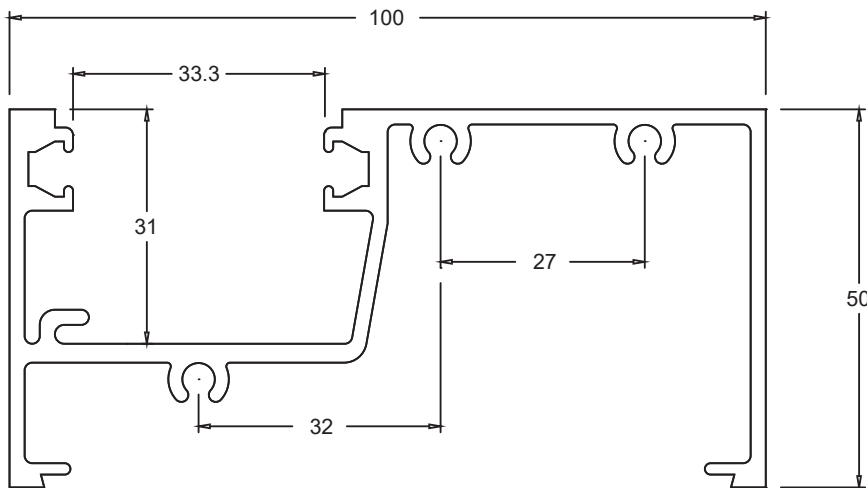
**DGF4501**

$$I_{xx} = 160.2 \times 10^3 \text{ mm}^4$$

$$I_{yy} = 852.9 \times 10^3 \text{ mm}^4$$

$$\text{A.P.} = 595 \text{ mm}$$

$$\text{P.P.} = 171 \text{ mm}$$

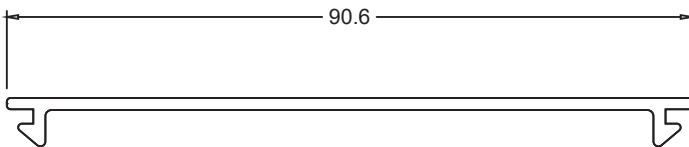
**TJ305**

Frame Filler For 100mm
Frame

$$\text{A.P.} = 206 \text{ mm}$$

$$\text{P.P.} = 100 \text{ mm}$$

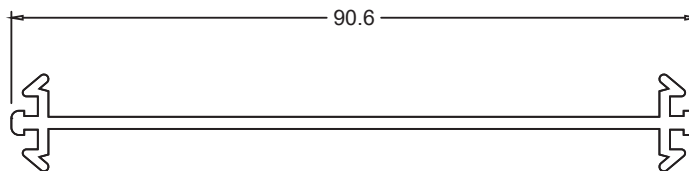
**TJ385**

Back To Back Adaptor
For 100mm Frame

$$\text{A.P.} = 247 \text{ mm}$$

$$\text{P.P.} = - \text{ mm}$$

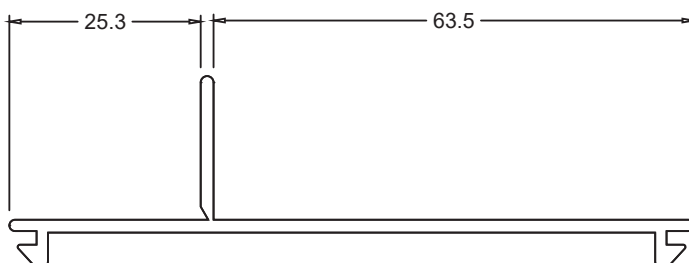
**TJ342**

Frame Reveal Adaptor
For 100mm Frame

$$\text{A.P.} = 244 \text{ mm}$$

$$\text{P.P.} = 130 \text{ mm}$$

Additional Profiles

Scale 1:1

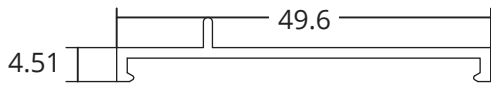

TJ732

Electric Chainwinder Cover

A.P. = 124 mm
P.P. = 100 mm

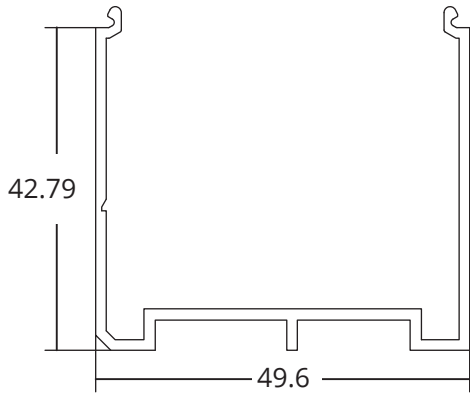

TJ731

Electric Chainwinder Base

A.P. = 309 mm
P.P. = 150 mm

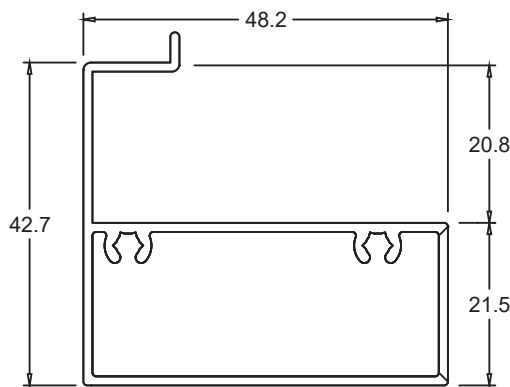

TJ734

Chain Winder Adaptor

$I_{xx} = 38.36 \times 10^3 \text{ mm}^4$
 $I_{yy} = 70.02 \times 10^3 \text{ mm}^4$

A.P. = 211 mm
P.P. = 211 mm

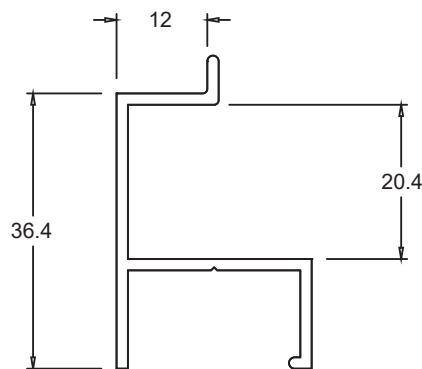

TJ737

Chain Winder Adaptor

$I_{xx} = 25.95 \times 10^3 \text{ mm}^4$
 $I_{yy} = 14.71 \times 10^3 \text{ mm}^4$

A.P. = 208 mm
P.P. = 100 mm

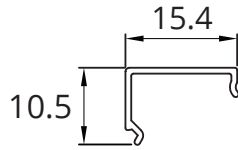
**JM2811**

Door Stop Cover
Available in PVC (1688)

A.P. = 59 mm
P.P. = 100 mm

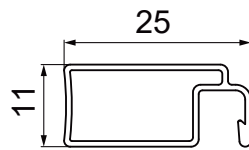
**HFF180**

11mm Flyscreen Frame

$I_{xx} = 0.956 \times 10^3 \text{ mm}^4$
 $I_{yy} = 3.758 \times 10^3 \text{ mm}^4$

A.P. = 85 mm
P.P. = 100 mm

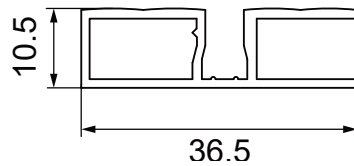
**WF001**

Standard Security Screen
Frame

$I_{xx} = - \times 10^3 \text{ mm}^4$
 $I_{yy} = - \times 10^3 \text{ mm}^4$

A.P. = 140 mm
P.P. = 100 mm

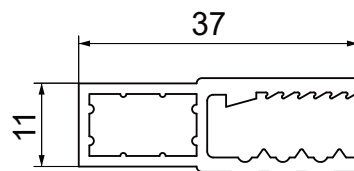
**AU01002**

Screenguard Frame

$I_{xx} = 3.752 \times 10^3 \text{ mm}^4$
 $I_{yy} = 19.202 \times 10^3 \text{ mm}^4$

A.P. = 152 mm
P.P. = 100 mm

Small Parts

	Code	Description	U.O.M	BOX QTY.
	1080**	Whitco Mk8 Non-Locking Chainwinder - Standard **Specify finish: Black: 1080-BL, Primrose: 1080-PR, White: 1080-WH	Each	10
	1082	Whitco Mk8 Non-Locking Chainwinder - Black Non Corrosive	Each	10
	1090	Whitco Mk8 Locking Chainwinder - K/N 32381 - Standard **Specify finish: Black: 1090-BL, Primrose: 1090-PR, White: 1090-WH, Silver: 1090-SCA	Each	10
	1092	Locking Chainwinder - Black K/N 32381 - Non-corrosive **Specify finish: Black: 1092-BL, Primrose: 1092-PR, White: 1092-WH, Silver: 1092-SCA	Each	NA
	1227-BL	Locking Chainwinder - Black stainless steel chain - Keyed 92608	Each	
	1227-WH	Locking Chainwinder - Black stainless steel chain - Keyed 92608	Each	
	1229-BL	Locking Twin Chainwinder - Black stainless steel chain	Each	
	1229-WH	Locking Twin Chainwinder - White stainless steel chain	Each	
	1098-SQ	Chain Length Restriction Plug - Works with 1080, 1082, 1090, 1092 10 Per bag	Bag	10
	1099	Chainwinder Bracket - Black - Height = 20mm	Each	20
	1241	Awning Handle - Wedgeless - Left Hand - Black Non-Locking	Each	10

Small Parts

	Code	Description	U.O.M	BOX QTY.
	1244	High Performance Cam Handle Lock - Right Hand - Black Non-Locking Suits: TJ741	Each	10
	1245	High Performance Cam Handle Lock 1 - Left Hand - Black Non-Locking Suits: TJ741	Each	10
	1246	High Performance Cam Handle Lock - Right Hand - Black Locking Suits: TJ741	Each	10
	1247	High Performance Cam Handle Lock - Left Hand - Black Locking Suits: TJ741	Each	10
	1285	Stainless Steel Restrictor Stay - Heavy Duty	Pair	25pr
	1450	Glazing Tape - D/Sided Black PVC - 1.6mm x 12mm - 50m Roll	Roll	20
	1451	Glazing Tape - D/Sided Black PVC - 3.2mm x 12mm - 25m Roll	Roll	20
	1452	Glazing Tape - D/Sided Black PVC - 4.8mm x 12mm - 15.2m Roll	Roll	20
	1453A	Glazing Tape - D/Sided Black PVC - 6.4mm x 12mm - 15.2m Roll	Roll	18
	1600	Bulb Seal PVC - 250m Roll	Roll	1
	1601	Bulb Seal Co-Extruded - 100m Roll	Roll	N/A

Small Parts

	Code	Description	U.O.M	BOX QTY.
	2641	Qlon - Push in - 400m Roll Suits: TJ741	Roll	N/A
	1615	Glazing Wedge PVC - 200m Roll	Roll	1
	1620	Glazing Wedge PVC - 200m Roll	Roll	1
	1630	Glazing Wedge PVC - 200m Roll	Roll	1
	1605	Glazing Channel to Suit 6mm Awning Window - 200m Roll Suits: TJ738/739	Roll	N/A
	1931	Glazing Wedge - 100m Roll	Roll	1
	1623	Glazing Wedge - 100m Roll	Roll	1
	1933	Glazing Wedge - 125m Roll	Roll	1
	1863	50mm Plastic Corner Stake for TJ741/770 - (left & right handed)	Bag	20
	1864	50mm Sash Corner Plate	Bag	100
	1855	50mm Metal Corner Stake for TJ741/770	Bag	20
	BDX-CV-CS-G/H/AW	CSG Frame / Hinged / Hook Awning Hydraulic Tool		

Electric Chainwinder Box: Doric Ventus



SCE100S	
Voltage	24V DC
Push/Pull Force	250N
Chain Projection	100mm
Max Window Height	1500mm
Max Window Width	350mm - 1200mm
Chain	304 Stainless Steel
Doric Code	9052637 - SCE100S



SCE300S	
Voltage	24V DC
Push/Pull Force	250N
Chain Projection	300mm
Max Window Height	1500mm
Max Window Width	350mm - 1200mm
Chain	304 Stainless Steel
Doric Code	9052809 - SCE300S

SIZE CHART					
Configuration	Max Height	Max Width	Max m ²	Max Weight	Force of Motor
SCE100s					
Single	1500mm	1200mm	1.8	25kg	250N
Two Units (Synchronised)	1200mm	2400mm	2.88	50kg	Combined 500N
SCE300s					
Single	1500mm	1200mm	1.8	25kg	250N
Two Units (Synchronised)	1200mm	2400mm	2.88	50kg	Combined 500N

For a comprehensive list of required and optional hardware for this system, please contact your Darley representative.

Electric Chainwinder Box: FSA Fentec



ECO 230V	
Voltage	110/240V AC
Push/Pull Force	250N
Chain Projection	125, 240, 360mm
Min Window Height (Determined by Chain Projection)	150, 250, 350mm
FSA Code	F-ECOSY-C

ECO 24V	
Voltage	24V DC
Push/Pull Force	250N
Chain Projection	125, 240, 360mm
Min Window Height (Determined by Chain Projection)	150, 250, 350mm
FSA Code	F-ECOSY24-C

SIZE CHART			
Chain Projection	Min Height	Max Weight	Force of Motor
125mm	150mm	56kg	250N
240mm	250mm	48kg	250N
360mm	350mm	45kg	250N

For a comprehensive list of required and optional hardware for this system, please contact your Darley representative.

Electric Chainwinder Box: Yale Aeron

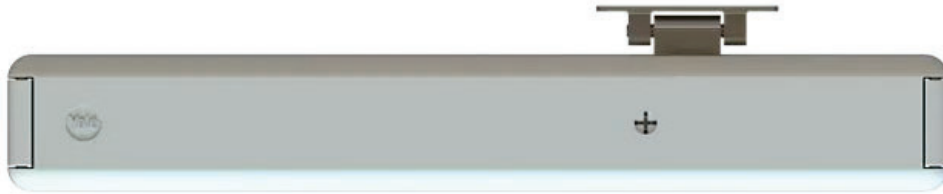

AERON WIRELESS ACTUATOR	
Voltage	24V DC
Push/Pull Force	90N
Chain Projection	100, 150, 200, 250mm
Min Window Height (Determined by Chain Projection)	300mm
Yale Code	YAR/WSWA/1/

SIZE CHART			
Chain Projection	Min Height	Max Weight	Force of Motor
125mm			
240mm			
360mm			

For a comprehensive list of required and optional hardware for this system, please contact your Darley representative.

Performance Summary

PERFORMANCE								
System	Test Size	Panel Size	Ser	Water	Ult	Report	Max	Glass
100mm CDG (Chainwinder)	1800x1500	900x1550	2000	2300	5000	AZT0484.21	1850H x 1800W	6mm
100mm CDG (Chainwinder + Cams)	1800x1500	900x1550	2500	2300	5000	AZT0483.21	1850H x 1800W	6mm
150mm CDG (Chainwinder + Cams)	3490x1050	2000x890	3000	750	5100	AZT0630.22	1850H x 1800W	6-12-6
150mm FDG (Twin Chainwinders)	3490x1550	1200x1388	3000	800	5000	AZT0638.22	1850H x 1800W	6-12-6
150mm FDG (Multipoint)	3454x1550	1200x1388	4000	800	5000	AZT0639.22	1850H x 1800W	6-12-6
100mm FDG (Chainwinder)	3490x1200	1800x1090	1200	850	5000	AZT0123.23	1850H x 1800W	6-12-6
150mm FDG (Chainwinder)	3490x1050	2000x890	1500	750	2500	AZT0629.22	1850H x 1800W	6-12-6
150mm FDG (Chainwinder + Cams)	3454x1250	2000x890	2000	850	5000	AZT0124.23	1850H x 1800W	6-12-6
100mm CDG (Twin Chainwinder)	3490x1850	1770x1710	1125	350	2500	AZT0474.23	1850H x 1800W	6-12-6

Performance

ACOUSTIC PERFORMANCE				
System	Rw	C : CTR	Report	Glass
CityView Hook Awning	38	-1 ; -2	TL769-08	12.5mm Hush
CityView Hook Awning	41	-3 ; -4	TL666-09-01	8clr / 10air / 10.5 Vlam Hush

BAL FIRE RATING			
System	BAL	Report	Glass
CityView Hook Awning	BAL-40	FRT210417	6mm Toughened

TESTED BY NEUTRAL THIRD PARTIES



See Performance Section for more detail.
Taller maximums may be achievable via strength charts
Size limitations are governed by design intent, glass selection and local wind load and deflection requirements.

For further technical assistance and fabricator selection contact Darley Aluminium.
An Engineer should be consulted to ensure selected framing meets the requirements as set out in the relevant Australian Standards

Configuration Performance

Water Rating:

All systems below rate to a minimum water rating of 350pa.
 Some configurations can achieve up to a water rating of 2300pa.
 Some configurations has been tested to AS 4284
 Please see 'Performance' section for more detail

Performance

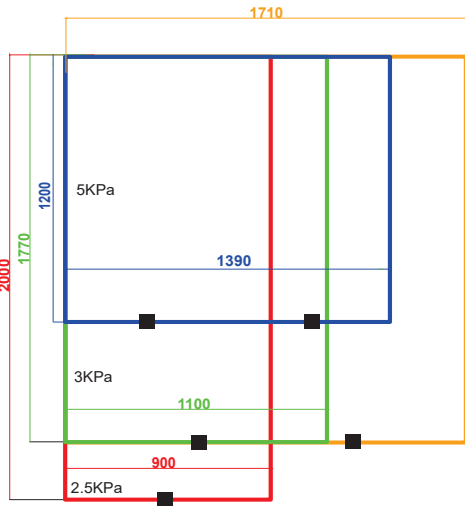

Chainwinder

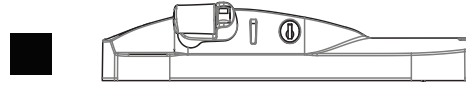

System	Sash Size (mm)	SLS (Pa)	Water Rating	ULS (Pa)	AZT
F/AW/F 100mm FDG (Chainwinder only)	1090 x 1800	1200	850Pa	3000	0123.23
AW/F 100mm CSG (Chainwinder only)	900 x 1550	2000	2300Pa	3000	0484.21
F/AW/F 150mm CDG (Chainwinder Only)	890 X 2000	1500	750Pa	2500	0629.22
F/AW/F (Twin Chainwinder)	1770 x 1710	1125	350Pa	2500	0474.23
F/AW/F (Twin Chainwinder)	1390 x 1200	3000	800Pa	5000	0638.22

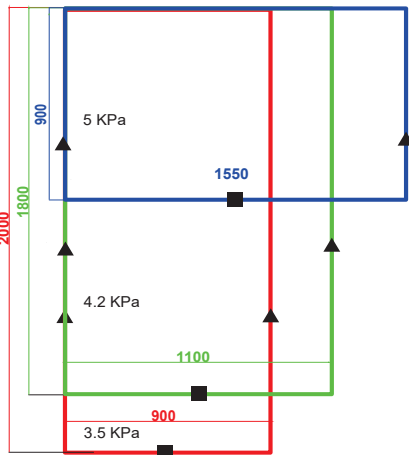

Cams



System	Sash Size (mm)	SLS (Pa)	Water Rating	ULS (Pa)	AZT
AW/F (Chain & Cams) 100mm CSG	900 x 1550	2500	2300	5000	0483.21
F/AW/F (ChainW & Cams) 150mm CDG	890 X 2000	2500	750	4200	0630.22
F/AW/F (ChainW & Cams) 100mm FDG	1090 x 1800	2000	850	3500	0124.23

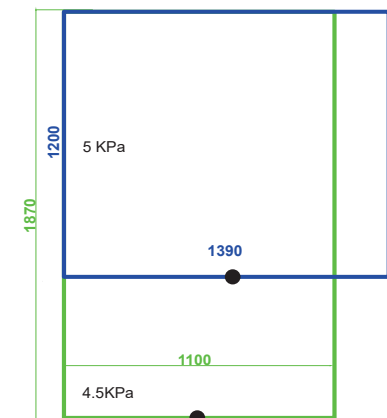

Multipoint



System	Sash Size (mm)	SLS (Pa)	Water Rating	ULS (Pa)	AZT
F/AW/F (MultiPoint) 100mm FDG	1090 x 1871	2500	850	5000	0125.23
F/AW/F (MultiPoint) 150mm FDG	1200 x 1388	4000	800	4500	0639.22

100mm CSG w/Chainwinder

LABORATORY TEST RESULTS: CityView 50mm Hook Awning

The following data was obtained from the results of the tests on the Darley Heavy Duty Awning Window as performed in the Azuma Testing Laboratory (NATA Accredited).

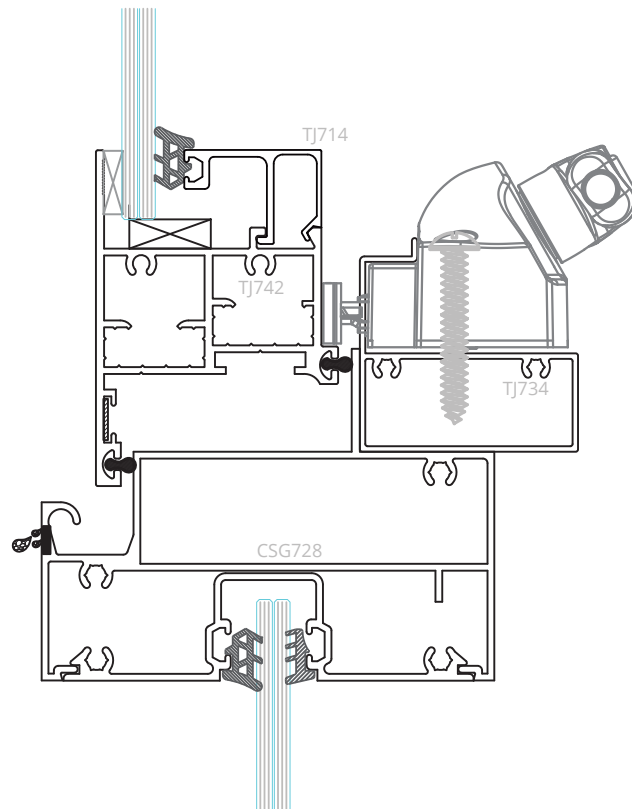
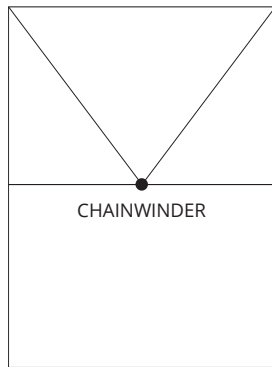

Performance

Test & Date	AZT0484.21, 19/12/2021
Test Size	1800mm H x 1500mm W
Jamb/Subsill	Jamb: CSG301 with Subsill
Serviceability Load	+/- 2000 Pa
Air Infiltration	+75 Pa = 0.26 L/s.m2 -75 Pa = 0.23 L/s.m2
Water Penetration	2300 Pa
Ultimate Strength	+ 5000 Pa - 3000 Pa

100mm CDG w/Chainwinder + Cams

LABORATORY TEST RESULTS: CityView 50mm Hook Awning

The following data was obtained from the results of the tests on the Darley Heavy Duty Awning Window as performed in the Azuma Testing Laboratory (NATA Accredited).

Performance

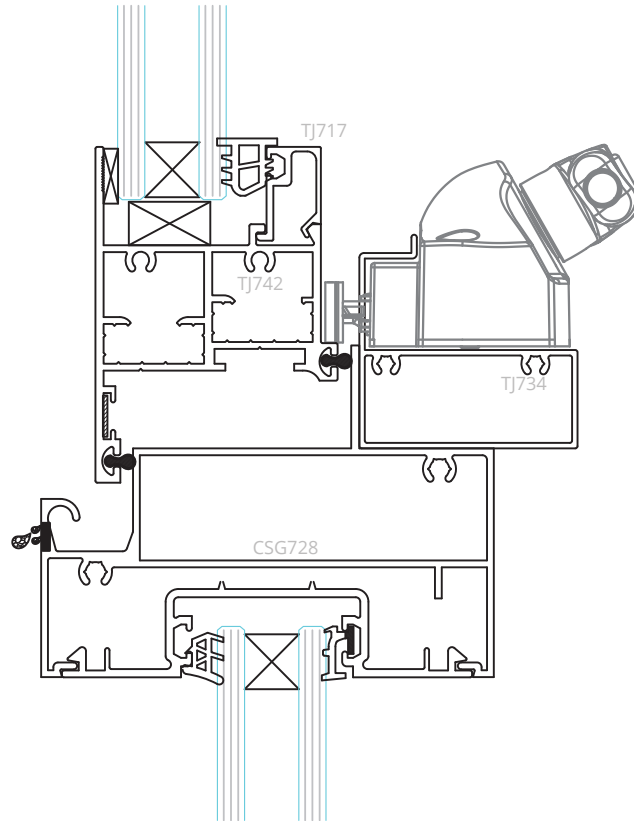
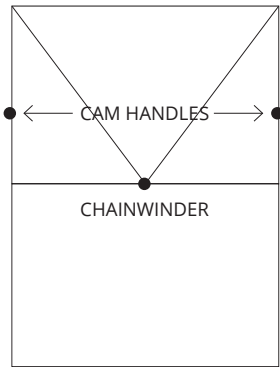

Test & Date	AZT0483.21, 19/12/2021
Test Size	1800mm H x 1500mm W
Jamb/Subsill	Jamb: CDG4390 with Subsill
Serviceability Load	+/- 2500 Pa
Air Infiltration	+75 Pa = 0.26 L/s.m ² -75 Pa = 0.23 L/s.m ²
Water Penetration	2300 Pa
Ultimate Strength	+/- 5000 Pa

150mm CDG w/ Chainwinder + Cams

LABORATORY TEST RESULTS: CityView 50mm Hook Awning

The following data was obtained from the results of the tests on the Darley Heavy Duty Awning Window as performed in the Azuma Testing Laboratory (NATA Accredited).

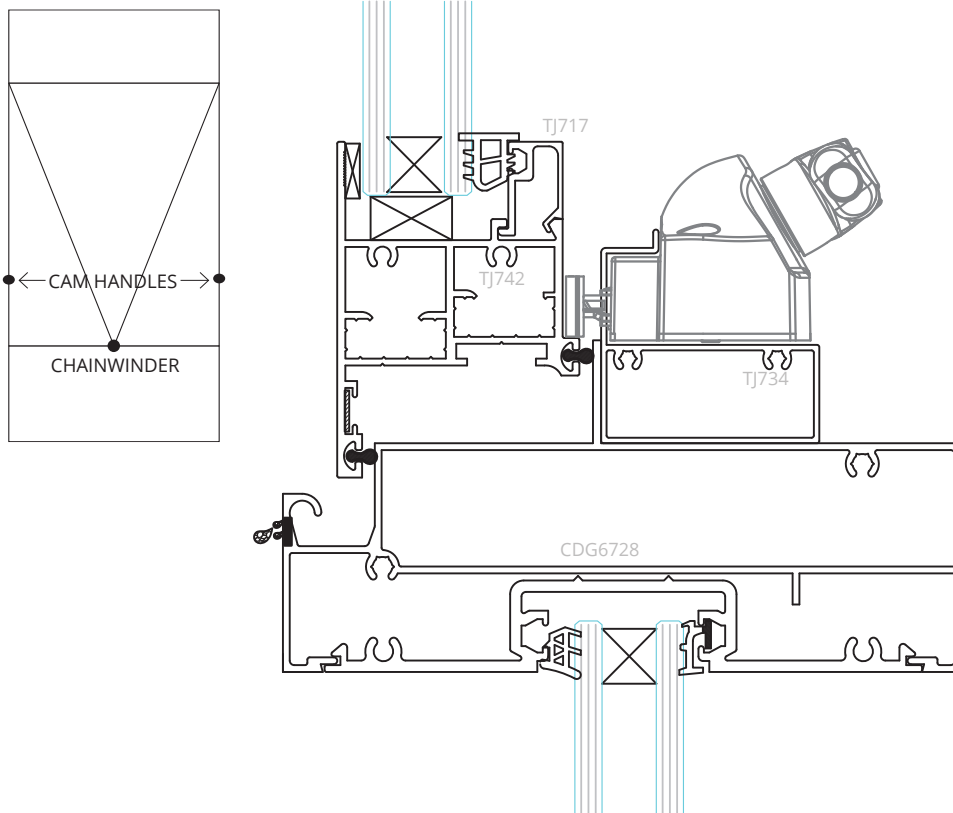

Performance

Test & Date	AZT0630.22, 13/12/2021
Test Size	3490mm H x 1050mm W
Jamb/Subsill	Jamb: CDG6501 with Subsill
Serviceability Load	+ 3000 Pa - 2500 Pa
Air Infiltration	+75 Pa = 0.01 L/s.m2 -75 Pa = 0.844 L/s.m2
Water Penetration	750 Pa
Ultimate Strength	+ 5100 Pa - 4200 Pa

150mm FDG w/ Twin Chainwinders

LABORATORY TEST RESULTS: CityView 50mm Hook Awning

The following data was obtained from the results of the tests on the Darley Heavy Duty Awning Window as performed in the Azuma Testing Laboratory (NATA Accredited).

Performance

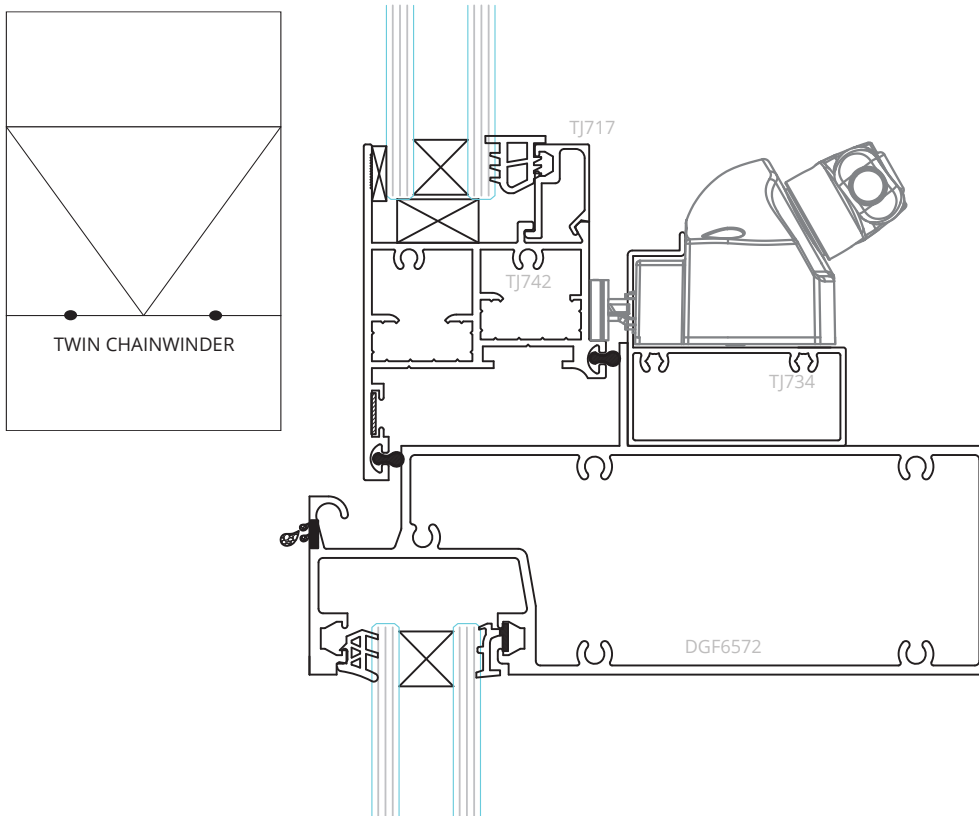

Test & Date	AZT0638.22, 14/12/2021
Test Size	3490mm H x 1550mm W
Jamb/Subsill	Jamb: DGF6561 with Subsill
Serviceability Load	+/- 3000 Pa
Air Infiltration	+75 Pa = 0.85 L/s.m2 -75 Pa = 0.78 L/s.m2
Water Penetration	800 Pa
Ultimate Strength	+/- 5100 Pa

150mm FDG with Multipoint

LABORATORY TEST RESULTS: CityView 50mm Hook Awning

The following data was obtained from the results of the tests on the Darley Heavy Duty Awning Window as performed in the Azuma Testing Laboratory (NATA Accredited).

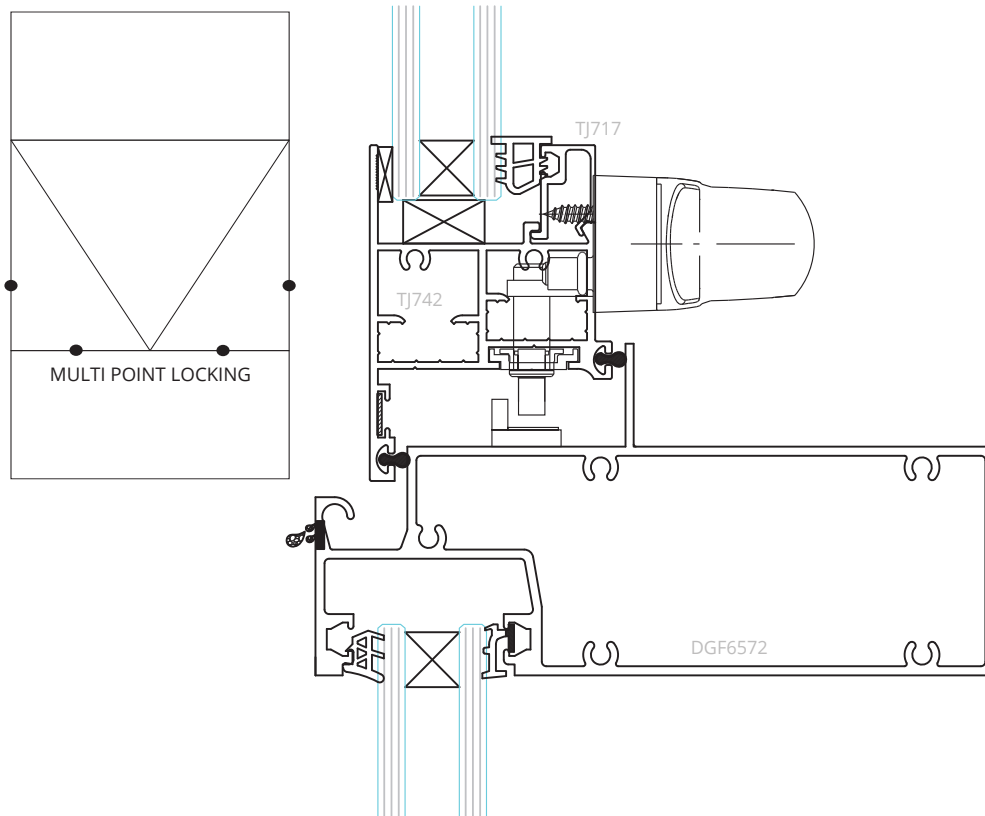

Performance

Test & Date	AZT0639.22, 15/12/22
Test Size	3454mm H x 1550mm W
Jamb/Subsill	Jamb: DGF6561 with Subsill
Serviceability Load	+/-4000 Pa
Air Infiltration	+75 Pa = 0.72 L/s.m2 -75 Pa = 0.78 L/s.m2
Water Penetration	800 Pa
Ultimate Strength	+ 5000 Pa - 4500 Pa

100mm FDG w/ Chainwinder

LABORATORY TEST RESULTS: CityView 50mm Hook Awning

The following data was obtained from the results of the tests on the Darley Heavy Duty Awning Window as performed in the Azuma Testing Laboratory (NATA Accredited).

Performance

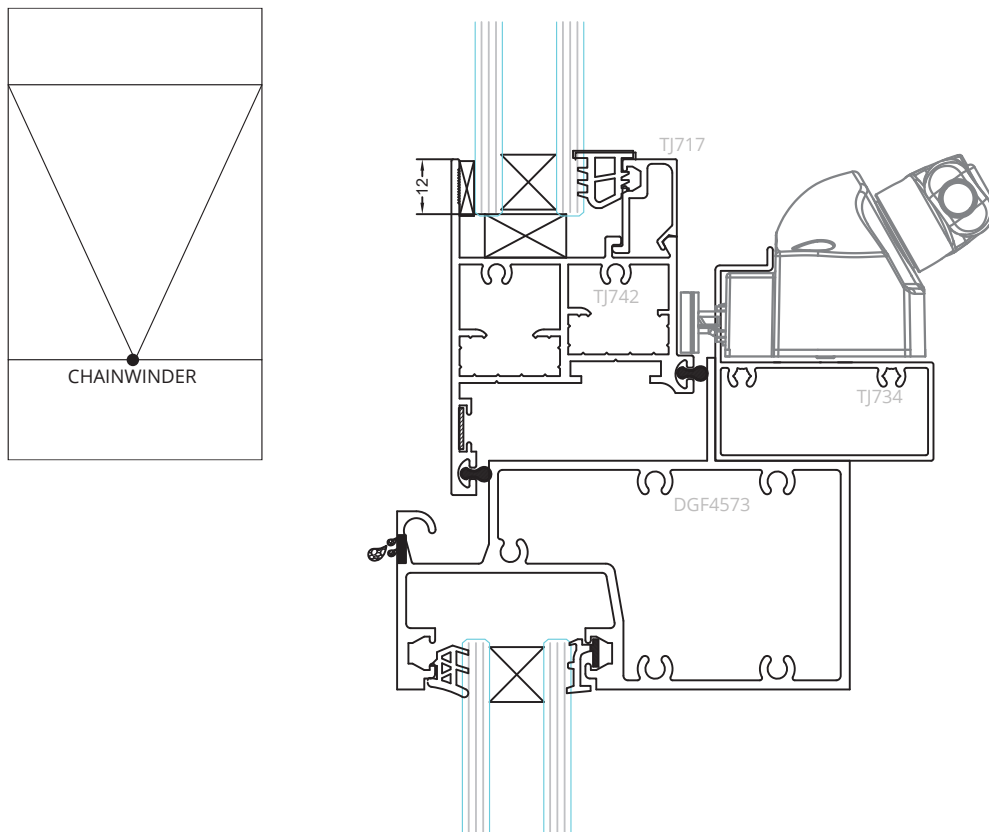

Test & Date	AZT0123.23, 19/04/23
Test Size	3490mm H x 1200mm W
Jamb/Subsill	Jamb: DGF4501 with Subsill
Serviceability Load	+/- 1200 Pa
Air Infiltration	+75 Pa = 0.11 L/s.m2 -75 Pa = 0.15 L/s.m2
Water Penetration	850 Pa
Ultimate Strength	+ 5000 Pa - 3000 Pa

100mm FDG w/ Multipoint

LABORATORY TEST RESULTS: CityView 50mm Hook Awning

The following data was obtained from the results of the tests on the Darley Heavy Duty Awning Window as performed in the Azuma Testing Laboratory (NATA Accredited).

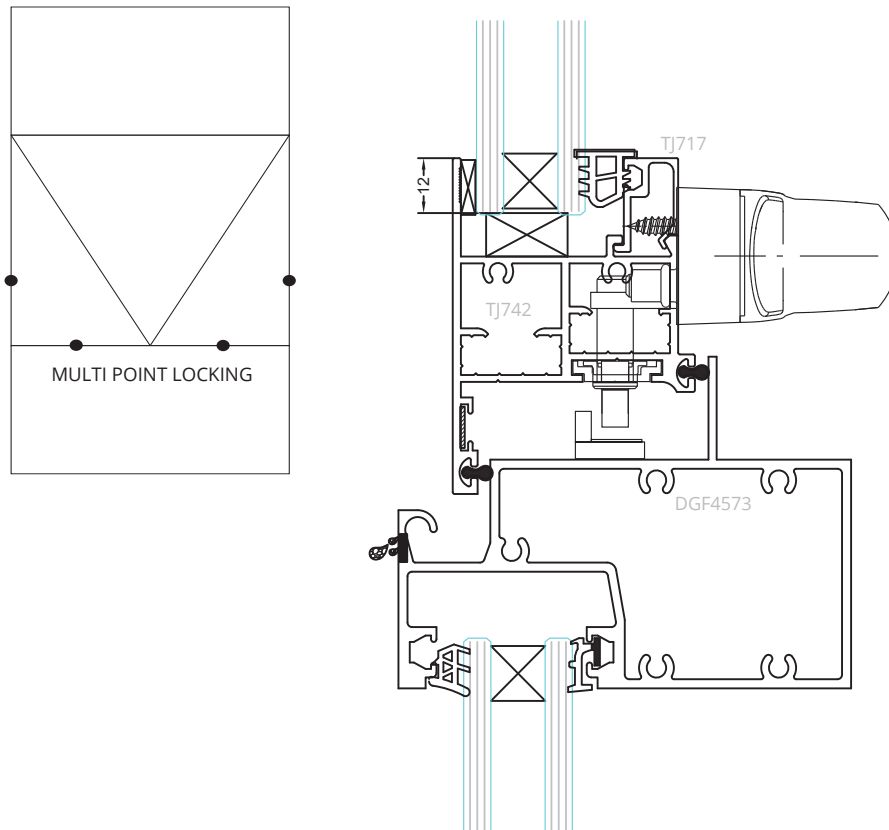

Performance

Test & Date	AZT0125.23, 19/04/23
Test Size	3454mm H x 1250mm W
Jamb/Subsill	Jamb: DGF4501 with Subsill
Serviceability Load	+/- 2500 Pa
Air Infiltration	+75 Pa = 0.11 L/s.m ² -75 Pa = 0.15 L/s.m ²
Water Penetration	850 Pa
Ultimate Strength	+ 5000 Pa - 5000 Pa

150mm FDG w/ Twin Chainwinder

LABORATORY TEST RESULTS: CityView 50mm Hook Awning

The following data was obtained from the results of the tests on the Darley Heavy Duty Awning Window as performed in the Azuma Testing Laboratory (NATA Accredited).

Performance

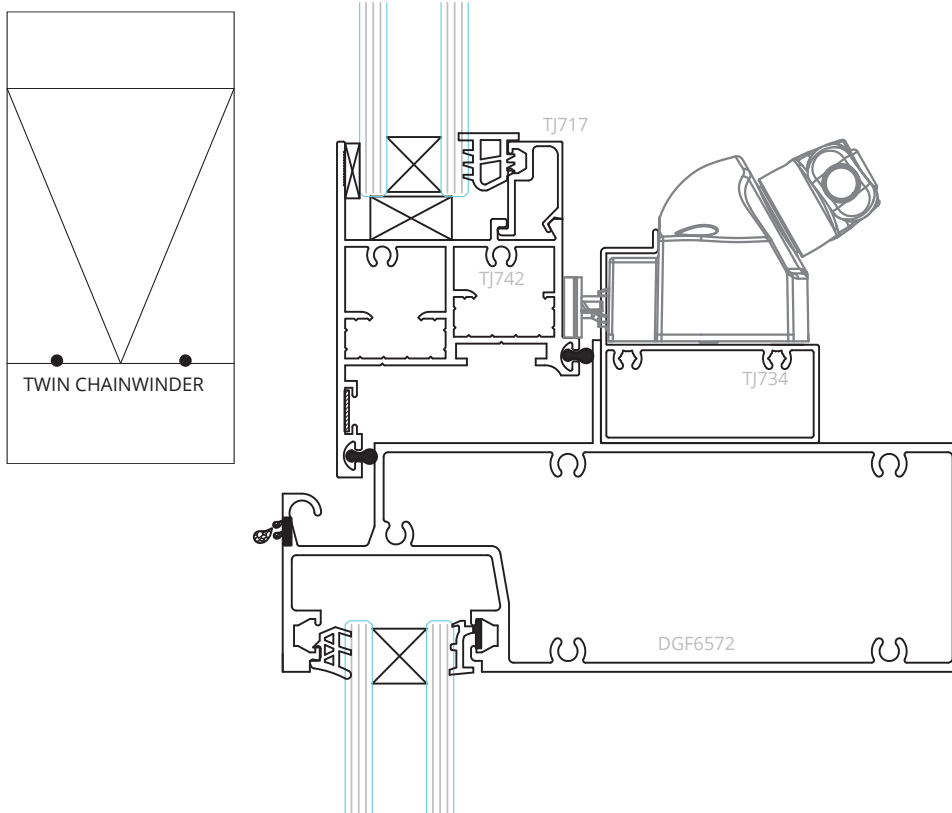

Test & Date	AZT0629.22, 12/12/22
Test Size	3490mm H x 1050mm W
Jamb/Subsill	Jamb: DGF6561 with Subsill
Serviceability Load	+/- 1500 Pa
Air Infiltration	+75 Pa = 0.507 L/s.m2 -75 Pa = 0.715 L/s.m2
Water Penetration	750 Pa
Ultimate Strength	+/- 2500 Pa

150mm FDG w/Chainwinder + Cams

LABORATORY TEST RESULTS: CityView 50mm Hook Awning

The following data was obtained from the results of the tests on the Darley Heavy Duty Awning Window as performed in the Azuma Testing Laboratory (NATA Accredited).

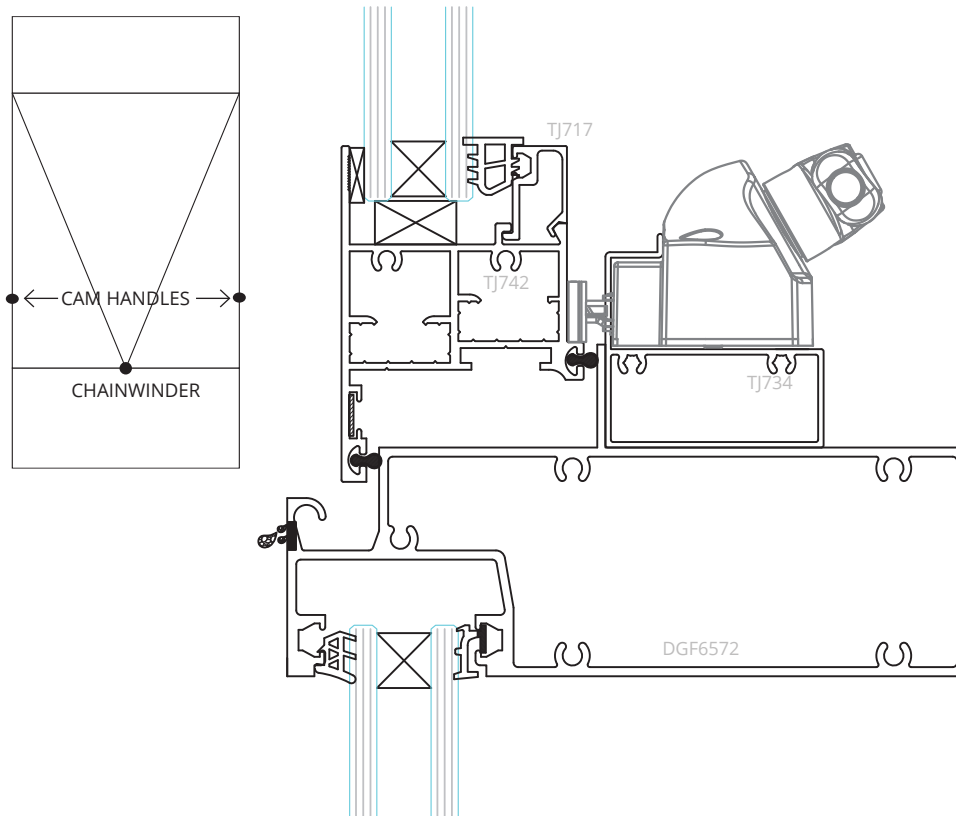

Performance

Test & Date	AZT0124.23, 19/04/23
Test Size	3454mm H x 1250mm W
Jamb/Subsill	Jamb: DGF6561 with Subsill
Serviceability Load	+/- 2000 Pa
Air Infiltration	+75 Pa = 0.507 L/s.m2 -75 Pa = 0.715 L/s.m2
Water Penetration	850 Pa
Ultimate Strength	+/- 3500 Pa

100mm CDG w/Twin Chainwinder

LABORATORY TEST RESULTS: CityView 50mm Hook Awning

The following data was obtained from the results of the tests on the Darley Heavy Duty Awning Window as performed in the Azuma Testing Laboratory (NATA Accredited).

Performance

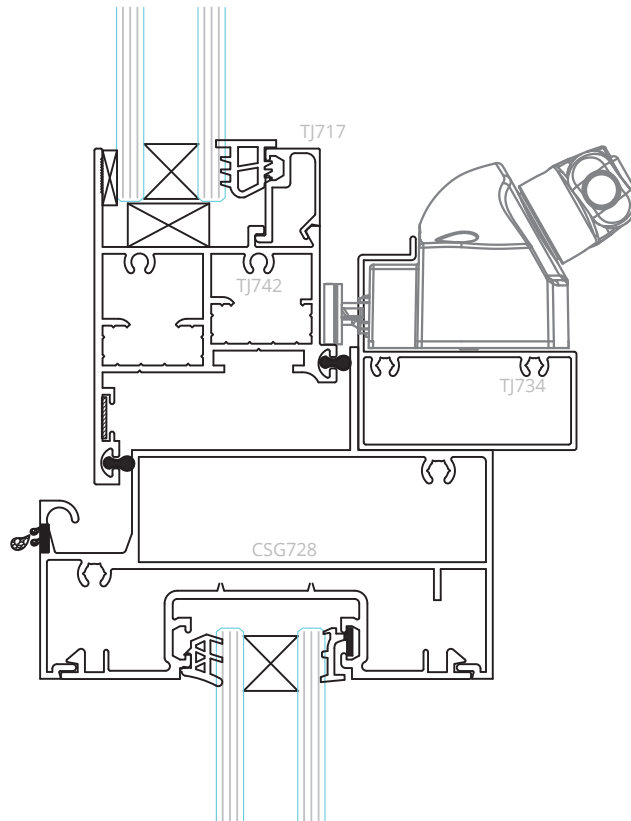
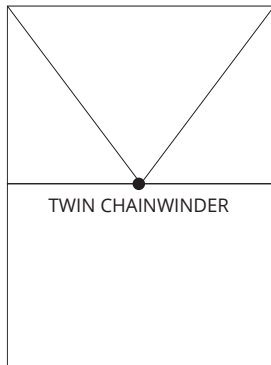

Test & Date	AZT0474.23, 09/12/2021
Test Size	3490mm H x 1850mm W
Jamb/Subsill	Jamb: CDG4390 with Subsill
Serviceability Load	+/- 1125 Pa
Air Infiltration	+75 Pa = 0.06 L/s.m ² -75 Pa = 0.18 L/s.m ²
Water Penetration	350 Pa
Ultimate Strength	+/- 2500 Pa

Acoustic Test Report

LABORATORY TEST RESULTS: CityView 50mm Hook Awning Window

Test Report No. : TL769-08
 Date: 23/02/23
 Glass Type: 12.5mm Hush
 Acoustic Rating: 38 Rw

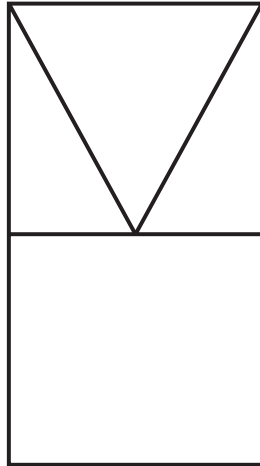

Measurement Details & Results²

Frequency (Hz)	Specimen R Value (dB)		95 % Conf δ (dB)
	1/3 Octave	Whole Octave	
100	28.7		1.7
125	27.5	28.8	2.4
160	30.6		1.4
200	32.5		1.4
250	32.4	32.9	1.6
315	34.1		1.0
400	34.5		0.8
500	35.1	34.8	0.5
630	35.0		0.3
800	34.5		0.3
1000	38.6	37.0	0.2
1250	40.0		0.2
1600	40.1		0.2
2000	40.1	40.2	0.2
2500	40.3		0.1
3150	40.7		0.2
4000	42.3	42.1	0.3
5000	43.7		0.5

Performance Index Numbers
 R_w (C; C_{tr}) = 38 (-1; -2) dB
 STC = 38

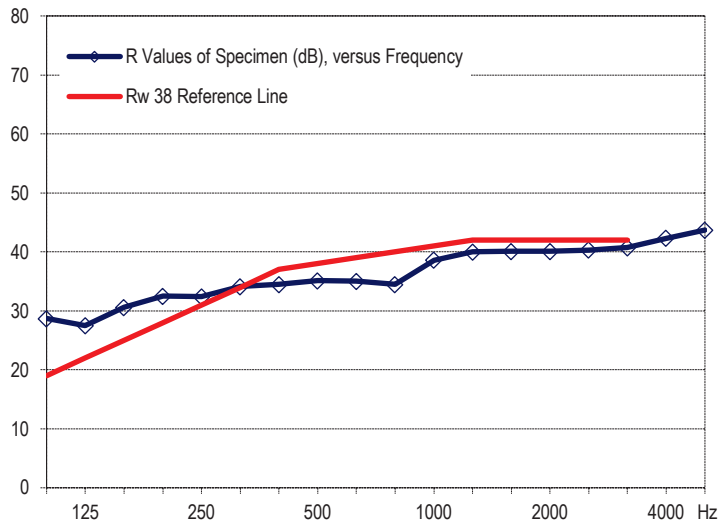

Acoustic

Acoustic Test Report

LABORATORY TEST RESULTS: CityView 50mm Hook Awning Window

Test Report No. : TL666-09-01
 Date: 01/05/2019
 Glass Type: 8clr / 10air / 10.5 Vlam Hush
 Acoustic Rating: 41 Rw

Measurement Details & Results

Freq (Hz)	Specimen R Value ² (dB)		95 % Conf δ (dB)
	1/3 Octave	Whole Octave	
100	26.9		1.1
125	22.4	25.3	1.3
160	29.3		1.1
200	30.9		1.1
250	35.2	33.4	1.1
315	35.7		0.5
400	39.0		0.7
500	39.7	40.0	0.4
630	41.8		0.2
800	41.6		0.2
1000	40.9	40.5	0.2
1250	39.4		0.2
1600	40.1		0.1
2000	40.9	41.2	0.2
2500	43.0		0.2
3150	43.3		0.2
4000	45.7	45.0	0.3
5000	46.8		0.2

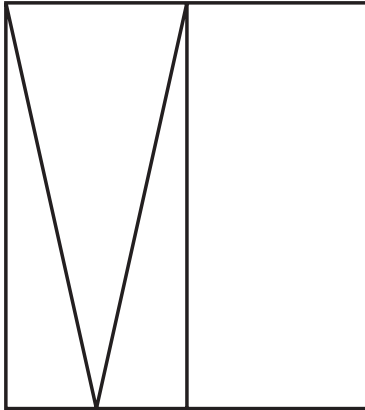

Performance Index Numbers

R_w (C; C_{tr}) = 41 (-2; -4) dB
 STC = 41

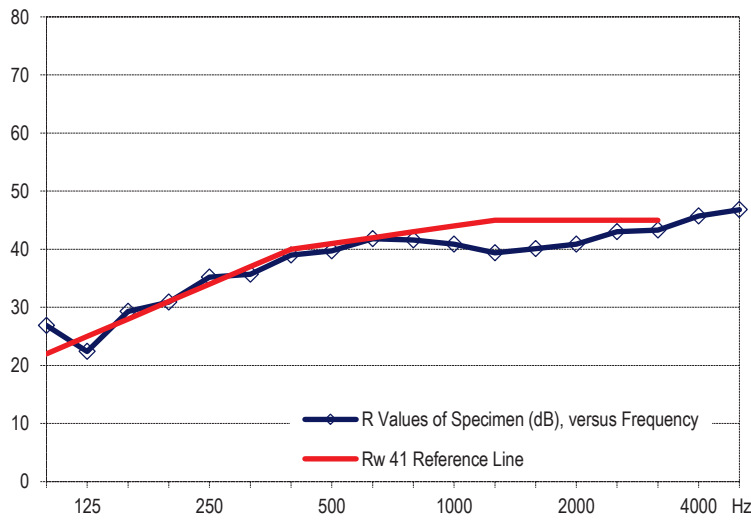

Acoustic

BAL Compliance

Bushfire attack levels achievable via test report no. FRT210417

Test Standard: Clauses 14 and 16 of AS 1530.8.1:2018

Test Sponsor: Darley Aluminium Trading Pty Ltd

Product: Darley CityView Combination Window System

Bushfire Attack Level (BAL) Exposure: 40 kW/m²

Crib Class: AA

Job Number: FRT210417

Test Date: 10 March 2022 **Revision:** R1.0

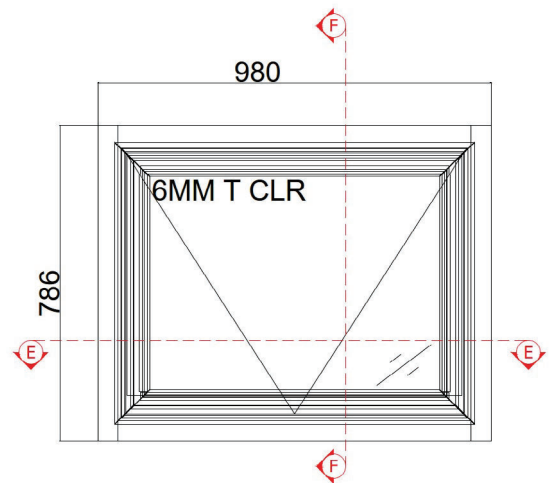

	BAL-12.5	BAL-19	BAL-29	BAL-40
FRAME	Low-level framing must be manufactured from either: <ul style="list-style-type: none"> • Metal, or • Bushfire resistant timber or • Timber species with a density greater than 650 kg/m³ or • Metal reinforced uPVC. 	Low-level framing must be manufactured from either: <ul style="list-style-type: none"> • Metal, or • Bushfire resistant timber or • Timber species with a density greater than 650 kg/m³ or • Metal reinforced uPVC. 	Low-level framing must be manufactured from either: <ul style="list-style-type: none"> • Metal, or • Bushfire resistant timber or • Metal reinforced uPVC. 	All framing must be metal .
GLAZING	Low-level glazing must be Grade A safety glass with a minimum thickness of 4 mm.	Low-level glazing must be Grade A safety glass with a minimum thickness of 5 mm. In all other locations where annealed glass is used, it must be protected by an external screen (see screen requirements).	All glazing must be toughened glass with a minimum thickness of 5 mm. Low-level glazing must be protected by an external screen (see screen requirements).	All glazing must be toughened glass with a minimum thickness of 6 mm. All glazing must be protected by an external screen (see screen requirements).
SCREENS	Openable portions of windows must be screened either internally or externally. Mesh or perforated sheet with a maximum aperture of 2mm manufactured from either: <ul style="list-style-type: none"> - Corrosion resistant steel (Screenguard), or - Bronze, or - Aluminium (Perfguard). Supporting frame must be manufactured from either: <ul style="list-style-type: none"> • Metal (including aluminium), or • Bushfire resistant timber or • Timber species with a density greater than 650 kg/m³. 	Openable portions of windows must be screened either internally or externally. Mesh or perforated sheet with a maximum aperture of 2mm manufactured from either: <ul style="list-style-type: none"> - Corrosion resistant steel (Screenguard), or - Bronze, or - Aluminium (Perfguard). Supporting frame must be manufactured from either: <ul style="list-style-type: none"> • Metal (including aluminium), or • Bushfire resistant timber or • Timber species with a density greater than 650 kg/m³. Where annealed glass is used, it must be protected by an external screen.	Openable portions of windows must be screened either internally or externally. Mesh or perforated sheet with a maximum aperture of 2mm manufactured from either: <ul style="list-style-type: none"> - Corrosion resistant steel (Screenguard), or - Bronze, or - Aluminium (Perfguard). Supporting frame must be manufactured from either: <ul style="list-style-type: none"> • Metal (including aluminium), or • Bushfire resistant timber. Low-level glazing must be protected by an external screen. Screen assemblies must be attached using metal fixings.	Fixed and openable portions of windows must be screened either internally or externally. Mesh or perforated sheet with a maximum aperture of 2 mm manufactured from either: <ul style="list-style-type: none"> - Corrosion resistant steel (Screenguard), or - Bronze. Aluminium mesh or perforated sheet cannot be used. Supporting frame must be manufactured from metal (including aluminium). Screen assemblies must be attached using metal fixings.
SEALS	N/A	N/A	N/A	Seals must be manufactured from silicone or have a flammability index less than 5.
HARDWARE	N/A	N/A	Externally fitted hardware that supports the sash in its functions of opening and closing must be metal unless shielded by metal frame components.	Externally fitted hardware that supports the sash in its functions of opening and closing, must be metal.

BAL

Glass & Rubber Combinations

CityView Universal Hook Awning Window			
Glass Thickness	Bead	Tape	Wedge or Bulb Seal
6mm	TJ714	1451	1931
8mm		1450	1623
10mm		1451	1615
12mm		1450	1620
16mm	TJ716	1451	1931
18mm		1450	1931
20mm		1450	1933
22mm		1450	1615
24mm		1450	1630
28mm	TJ717	1450	1623
30mm		1450	1933

Glazing

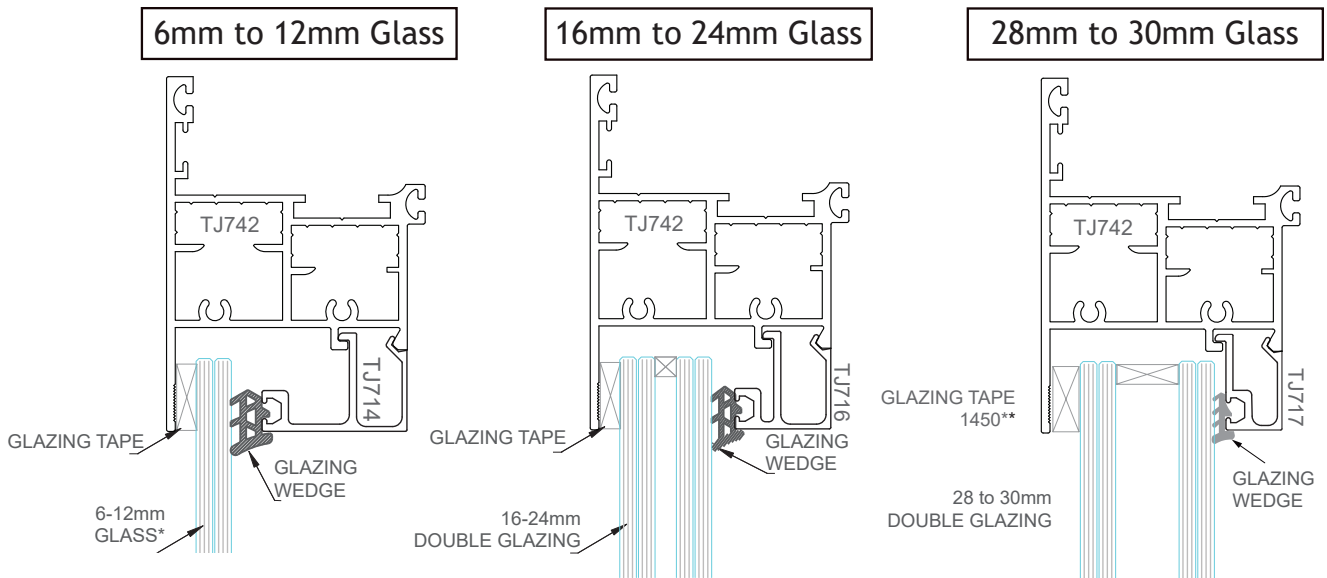

Energy Ratings Definitions

All Darley products have been rated under the Australian Fenestration Ratings Council (AFRC) Energy Rating Scheme.

Definitions

The following are terms used in describing the energy ratings of windows as defined by the Window Energy Rating Scheme (WERS). For further information go to www.agwa.com.au/WERS

U-Value (U_w)

U-Value measures how well a product prevents heat from escaping. It is a measure of the rate of non solar heat loss or gain through a material or assembly. U-Value ratings generally fall between 2.0 - 10.0 W/m² for Australian products. The rate of heat is indicated in the terms of the U-Value of a window assembly which includes the effect of the frame, glass, seals and any spacers. The lower the U-value, the greater a window's resistance to heat flow and the better its insulating value. The U-Value for a window takes account for the various U-values for the components making up the window, so you may see these in technical literature:

U_w is the value for the whole window and because of its importance is usually abbreviated to U.

U_c is the value at the centre of glass.

U_f is the value for the frame.

Solar Heat Gain Coefficient ($SHGC_w$)

SHGC measures how well a product blocks heat caused by sunlight. The SHGC is a fraction of incident solar radiation admitted through a window, both directly transmitted, and absorbed and subsequently released inward. SHGC is expressed as a number between 0 and 1. The lower a window's SHGC, the less solar heat it transmits.

Visible Transmittance (T_{vw})

Visible transmittance measures how much light comes in through a product. It is an optical property that indicates the amount of visible light transmitted. T_{vw} is expressed as a number between 0 and 1. The higher the number, the more light is transmitted.

Energy Ratings: Single Glazed

CityView 50mm Hook Awning - Single Glazed						
DAR	Glass Supplier	Glass	Uw	SHGC	Tvw	Air Infil.
DAR-044-01	OCEANIA	10.38GyLam	6.7	0.38	0.23	0
DAR-044-02	OCEANIA	6.38CPGy	5.8	0.33	0.218	0
DAR-044-03	OCEANIA	6.38CPNtl	5.8	0.34	0.329	0
DAR-044-04	OCEANIA	6.38CPGn	5.8	0.34	0.398	0
DAR-044-05	OCEANIA	6.38CPClr	5.8	0.43	0.458	0
DAR-044-06	GENERIC	6.38ClrLam	6.8	0.49	0.489	0
DAR-044-07	OCEANIA	6SolT	5.8	0.35	0.354	0
DAR-044-08	OCEANIA	6SolTGy	5.8	0.26	0.167	0
DAR-044-09	GENERIC	6Clr	6.8	0.51	0.493	0
DAR-044-10	OCEANIA	6Gy	6.8	0.37	0.233	0
DAR-044-11		6TS21	6.4	0.22	0.114	0
DAR-044-12	OCEANIA	6SpGn	6.8	0.34	0.372	0
DAR-044-13	OCEANIA	6SpGy	6.8	0.25	0.048	0
DAR-044-14	OCEANIA	6ET	5.8	0.44	0.455	0
DAR-044-15	OCEANIA	6EVSpGn	5.9	0.26	0.274	0
DAR-044-16	OCEANIA	6ETGy	5.8	0.32	0.223	0
DAR-044-17		6AZTS21	6.4	0.21	0.087	0
DAR-044-18	OCEANIA	6EVBGn	5.9	0.31	0.316	0
DAR-044-19	OCEANIA	6EVGy	5.9	0.28	0.179	0
DAR-044-20	OCEANIA	6EVClr	5.9	0.4	0.372	0
DAR-044-21	OCEANIA	6SpB	6.8	0.34	0.294	0
DAR-044-22	OCEANIA	6EVBz	6.7	0.34	0.211	0

KEY

Gy = Grey, Ntl = Neutral, Gn = Green, Clr = Clear, B = Blue, Bz = Bronze, Lam = Laminate, ComPls = Comfort Plus, SolT - SolTech, Sp = Super, ET = Energy Tech, EVan = Evantage, AZT = Solar Cool Azuria, Sngy = Sunergy.

NOTES

1. Percentage improvement figures are compared with using base-case Generic Window 1 (3mm clear in standard aluminium frame)
2. A negative percentage improvement figure indicates performance worse than the base-case window
3. A positive percentage improvement figure indicates performance better than the base-case window
4. Maximum air infiltration is 5.0 L/s.m² at a positive pressure difference of 75Pa as measured according to AS 2047
5. Static performance (U, SHFC, Twv, Tdw) Calculated using Window 5.2 and Therm 5.2 software (LBNL), 2000-2003
6. Annual energy performance (stars and % improvements) calculated using Nationwide House Energy Rating Software (AccuRate)
7. Results disclosed at National fenestration Rating Council (NFRC) regulations

Energy Ratings: Double Glazed

CityView 50mm Hook Awning - Double Glazed						
DAR	Glass Supplier	Glass	Uw	SHGC	Tww	Air Infil.
DAR-043-01		6Clr/12Ar/10.38Clr	4.8	0.43	0.426	0
DAR-043-02		6.38Gy/12Ar/6.38Clr	4.8	0.31	0.206	0
DAR-043-03		6.38Clr/12Ar/6.38Clr	4.9	0.41	0.431	0
DAR-043-04		6ETGy/12Ar/6.38Clr	4.4	0.26	0.196	0
DAR-043-05		6TS21 Gn/12Ar/6Clr	4.8	0.15	0.089	0
DAR-043-06	OCEANIA	6ET/12/6Clr	4.5	0.39	0.406	0
DAR-043-07	OCEANIA	6/12/6EVClr	4.5	0.38	0.343	0
DAR-043-08		6SpGn/12/6EVClr	4.5	0.22	0.258	0
DAR-043-09		6TS21/12/6EVClr	4.5	0.15	0.085	0
DAR-043-10		6EVClr/12/6Clr	4.5	0.36	0.343	0
DAR-043-11		6SpGn/12/6Clr	4.9	0.27	0.331	0
DAR-043-12	GENERIC	6Clr/12/6Clr	4.9	0.44	0.439	0
DAR-043-13		6InsEG/12/6Clr	4.9	0.27	0.326	0
DAR-043-14	OCEANIA	6InsEG/12/6ET	4.5	0.24	0.301	0
DAR-043-15		6InsTS21/12/6Clr	4.8	0.17	0.103	0
DAR-043-16		6EVClr/6Ar/6Clr	4.7	0.36	0.343	0
DAR-043-17		6SpGy/6Ar/6Clr	5	0.17	0.042	0
DAR-043-18		6EoGy/12/6Clr	4.9	0.31	0.219	0
DAR-043-19		6EoGy/12/6ET	4.5	0.28	0.203	0
DAR-043-20		6.5SOLOS Sil/12Ar/6SOLOS OE Acu	4.2	0.35	0.435	0
DAR-043-21		6.38SOLOS Ptk Wht/12Ar/6SOLOS OE Prv	4.3	0.29	0.329	0
DAR-043-22		6SOLOS Evo Clr/12Ar/6SOLOS OE Clr	4.2	0.37	0.44	0
DAR-043-23		6SOLOS Evo Gy/12Ar/6SOLOS OE Gy	4.2	0.23	0.207	0
DAR-043-24		GW 6Clr/12Ar/6OPLoE	4.24	0.37	0.437	0
DAR-043-25		GW 6LoE/12Ar/6Clr	4.224	0.19	0.348	0
DAR-043-26	G JAMES	6.38GyLam/10Ar/4LumaTherm	4.255	0.23	0.221	0
DAR-043-27	G JAMES	6.38ClrLam/10Ar/4LumaTherm	4.255	0.33	0.44	0
DAR-043-28	G JAMES	6.38LightGyLam/10Ar/4LumaTherm	4.255	0.27	0.309	0
DAR-043-29	G JAMES	4Clr/12Ar/4LumaTherm	4.238	0.36	0.449	0
DAR-043-30	G JAMES	4LumaTherm/12Ar/4Clr	4.238	0.35	0.449	0
DAR-043-31	G JAMES	4Gy/12Ar/4LumaTherm	4.238	0.26	0.279	0

KEY

Gy = Grey, Ntl = Neutral, Gn = Green, Clr = Clear, B = Blue, Bz = Bronze, Lam = Laminate, ComPls = Comfort Plus, SolT - SolTech, Sp = Super, ET = Energy Tech, EVan = Evantage, AZT = Solar Cool Azuria, Sngy = Sunergy.

NOTES

1. Percentage improvement figures are compared with using base-case Generic Window 1 (3mm clear in standard aluminium frame)
2. A negative percentage improvement figure indicates performance worse than the base-case window
3. A positive percentage improvement figure indicates performance better than the base-case window
4. Maximum air infiltration is 5.0 L/s.m2 at a positive pressure difference of 75Pa as measured according to AS 2047
5. Static performance (U, SHFC, Tww, Tdw) Calculated using Window 5.2 and Therm 5.2 software (LBNL), 2000-2003
6. Annual energy performance (stars and % improvements) calculated using Nationwide House Energy Rating Software (AccuRate)
7. Results disclosed at National fenestration Rating Council (NFRC) regulations

Glazing

Framing Options

All raw joints need to be sealed with small joint sealer or foam tab option.

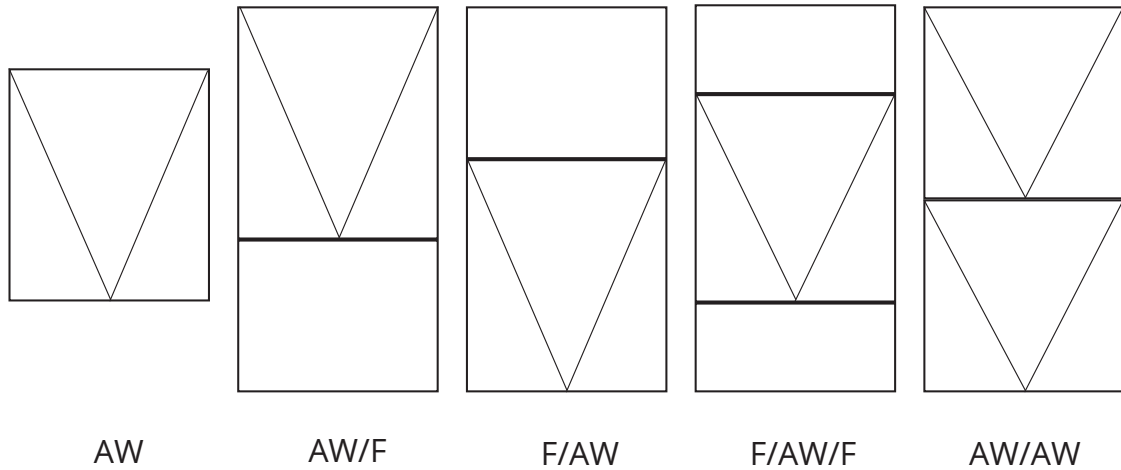

SASH = TJ742/TJ747			
FRAME TYPE	MAINFRAME	HEAD/SILL/ TRANSOM	AW/AW TRANSOM
101.6 X 45 CSG	TJ301	CSG728	CSG729
100 X 50 FSG	FGS401	DGF4573	CSG729
150 X 50 FSG	FGS601	DGF6572	CDG6729
100 X 50 CDG	CDG4301	CSG728	CSG729
150 X 50 CDG	CDG6501	CDG6728	CDG6729
100 X 50 FDG	DGF4501	DGF4572	CSG729
150 X 50 FDG	DGF6561	DGF6572	CDG6729

See also: Disclaimer and Copyright information on page 3

General Configuration

All raw joints need to be sealed with small joint sealer or foam tab option.

100mm Centre Glazed

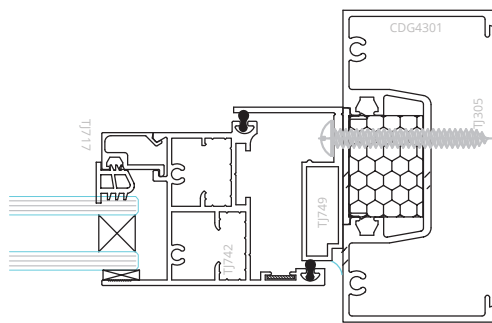
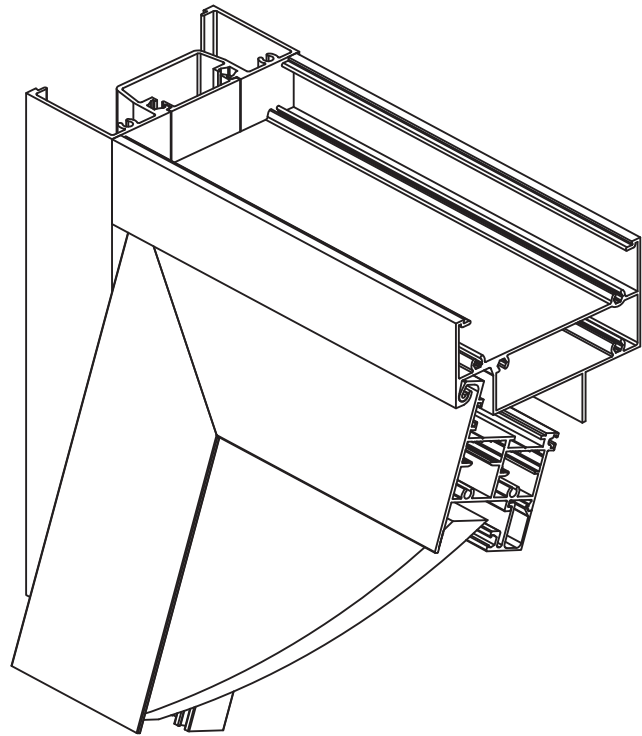
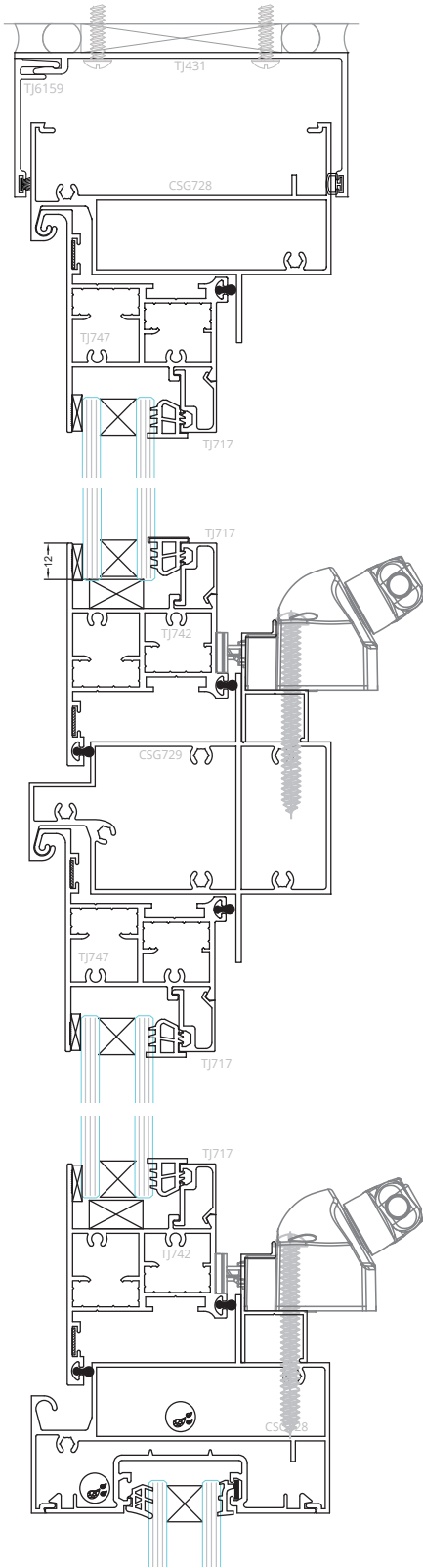

Fabrication

See also: Disclaimer and Copyright information on page 3

100mm Centre Glazed - Head/Sill

All raw joints need to be sealed with small joint sealer or foam tab option.

Fabrication

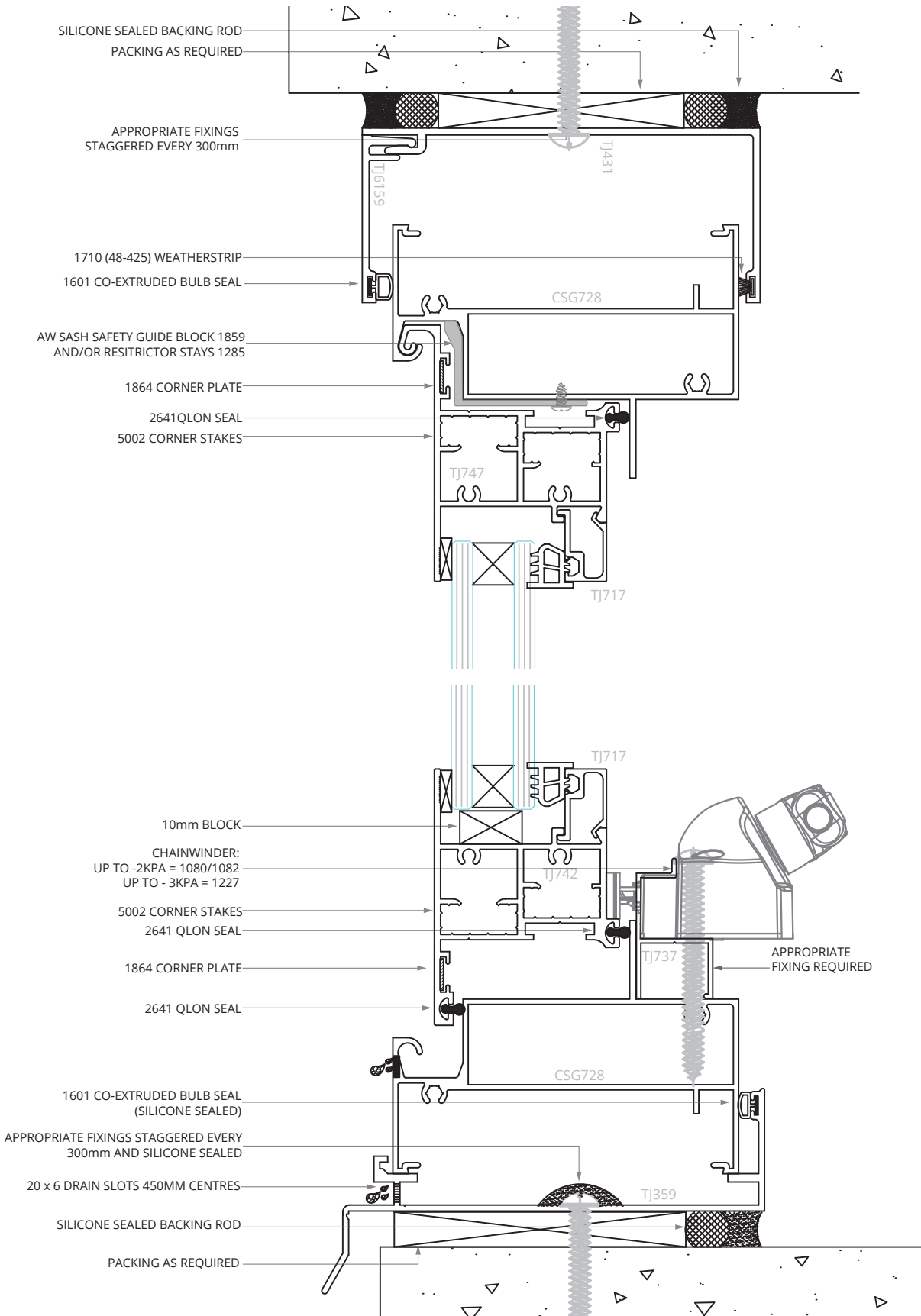

See also: Disclaimer and Copyright information on page 3

100mm Centre Glazed - Jamb

All raw joints need to be sealed with small joint sealer or foam tab option.

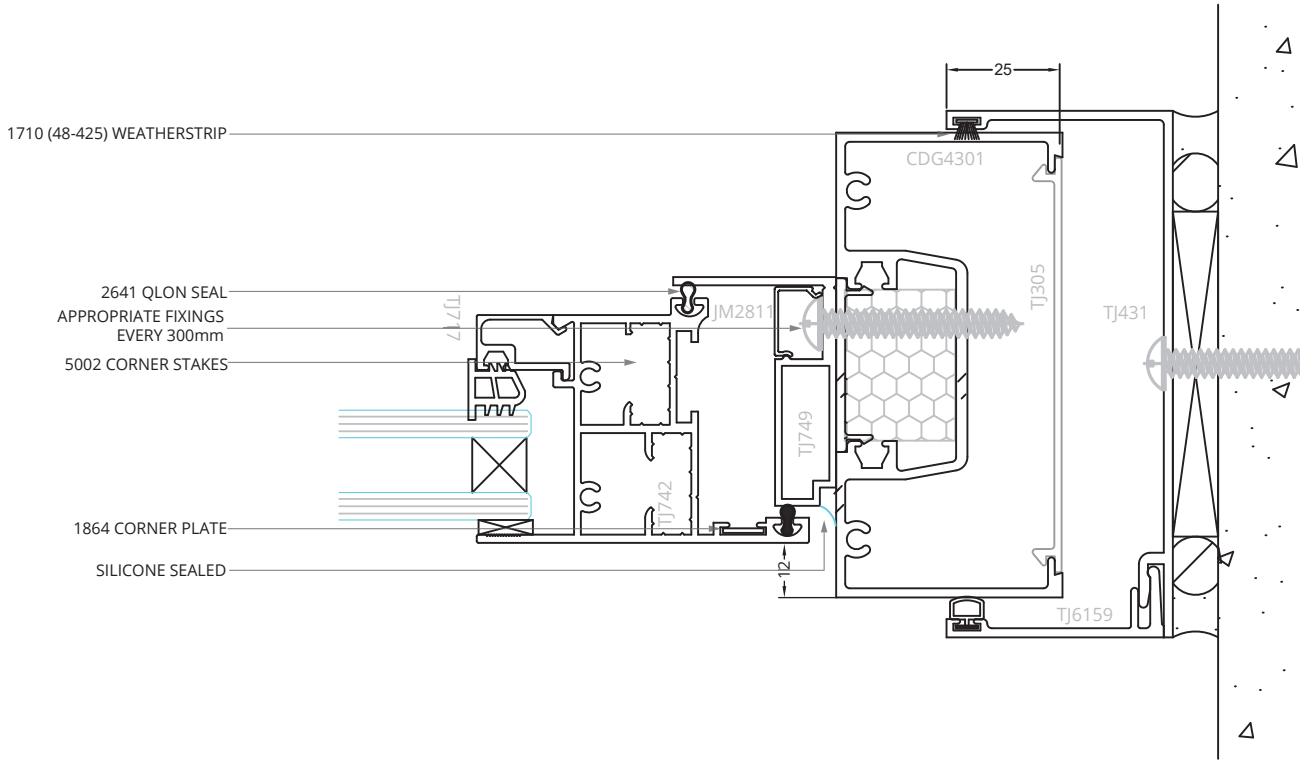

Fabrication

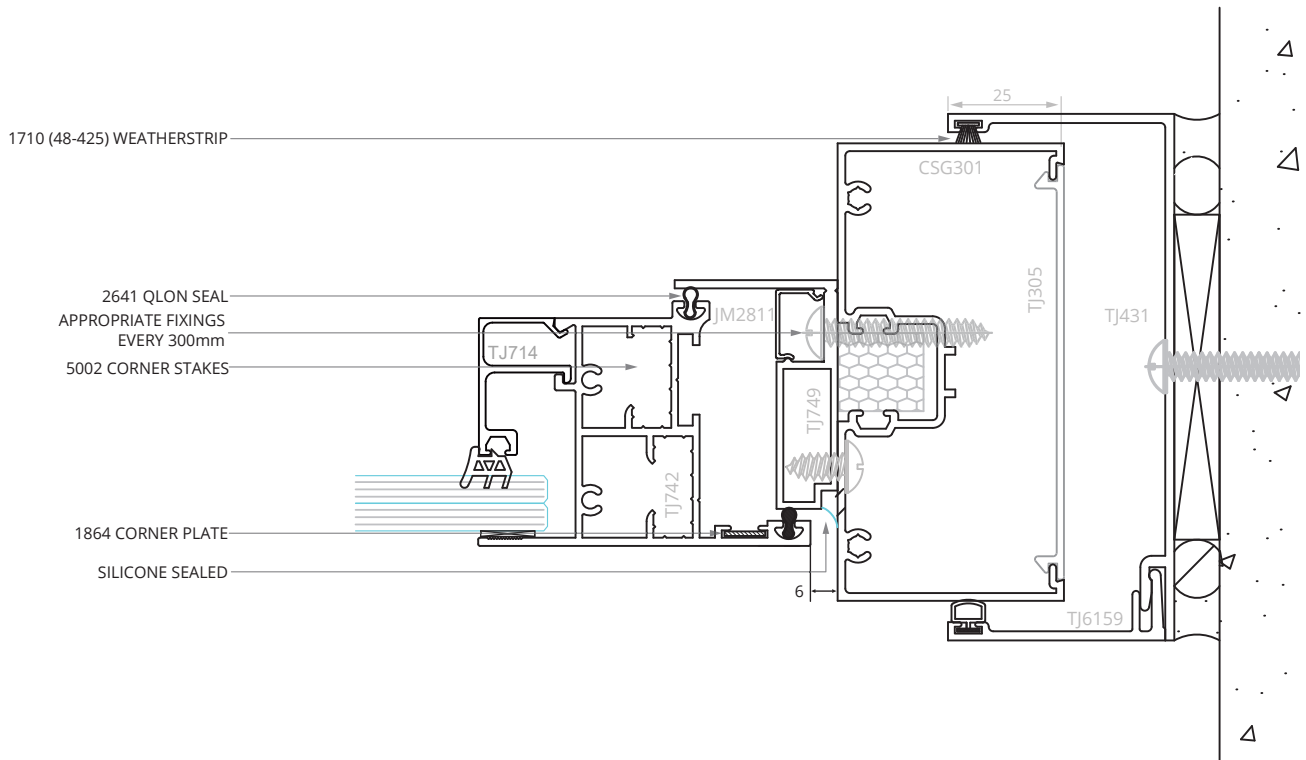

See also: Disclaimer and Copyright information on page 3

100mm Centre Glazed - Transom

All raw joints need to be sealed with small joint sealer or foam tab option.

Fabrication

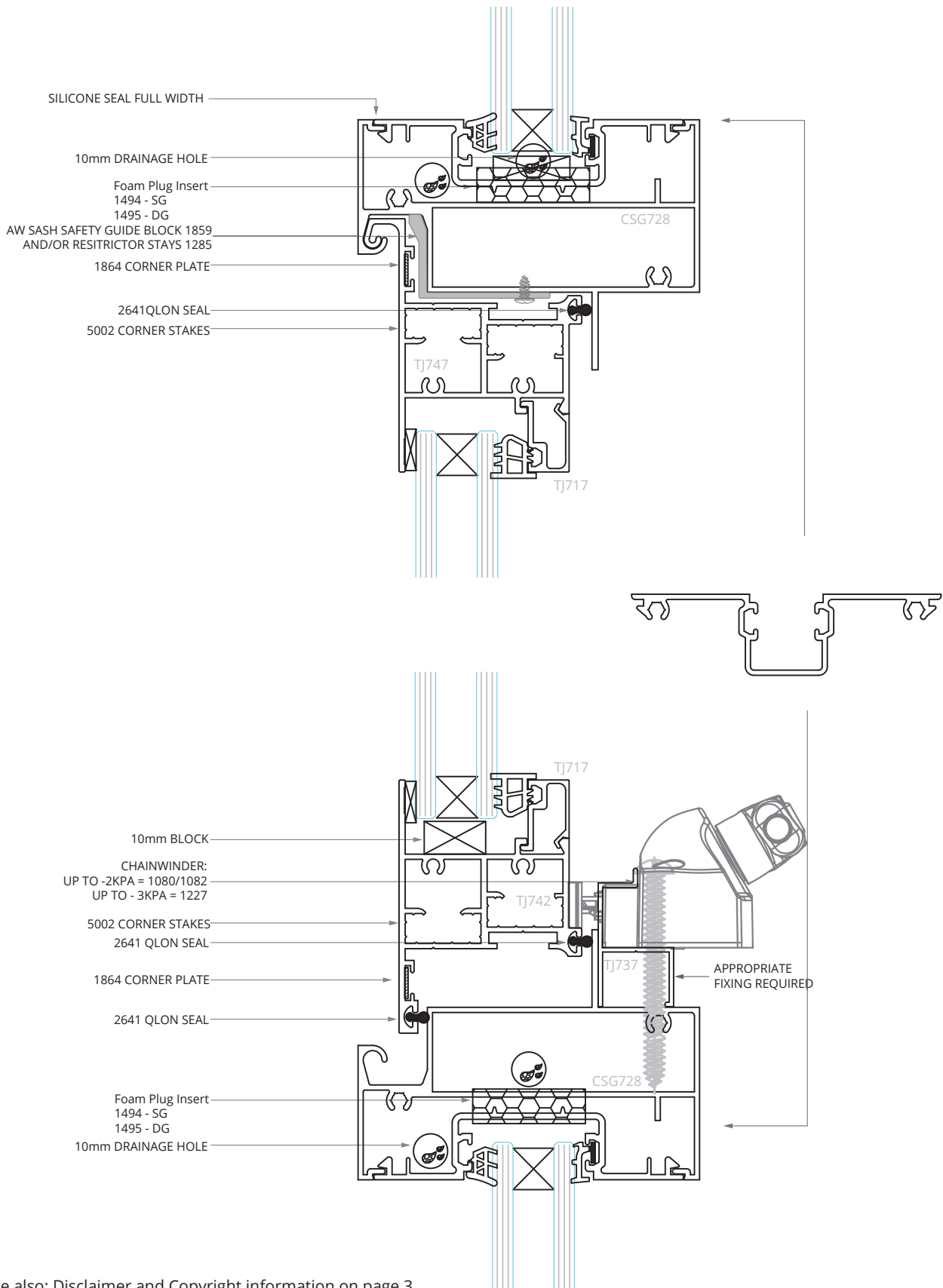

See also: Disclaimer and Copyright information on page 3

100mm Front Glazed

All raw joints need to be sealed with small joint sealer or foam tab option.

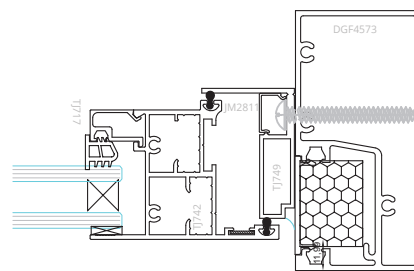
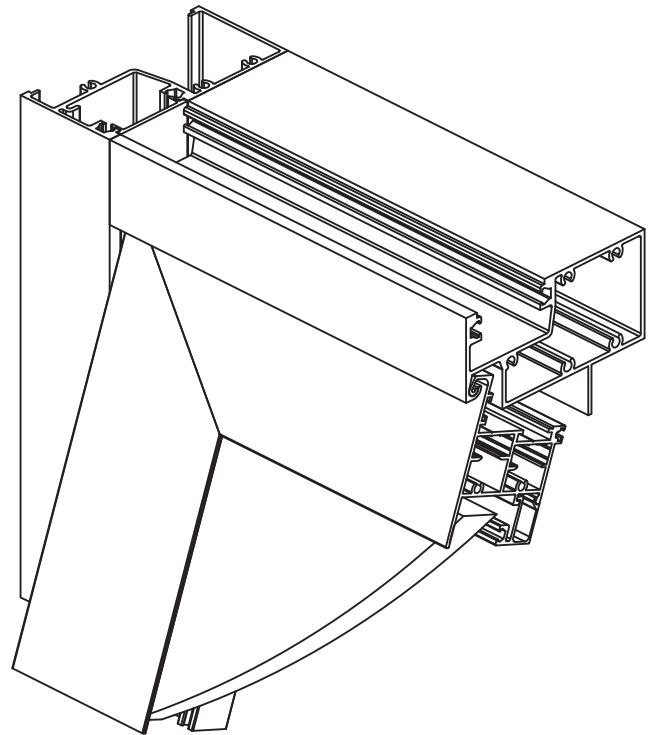
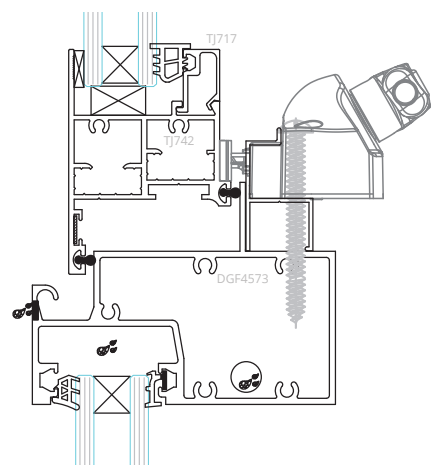
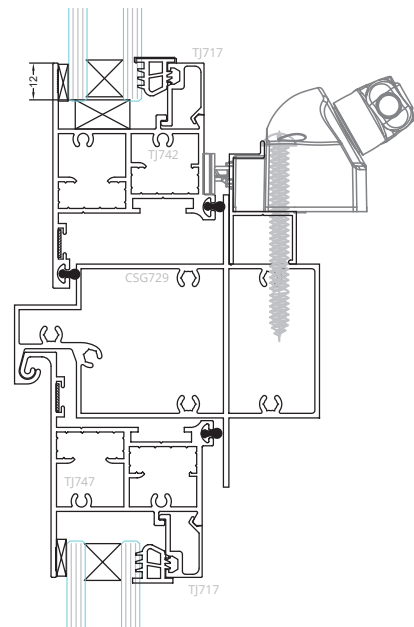
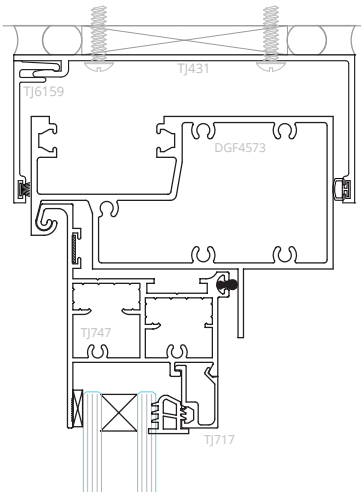

Fabrication

See also: Disclaimer and Copyright information on page 3

50MM HOOK AWNING

100mm Front Glazed - Head/Sill

All raw joints need to be sealed with small joint sealer or foam tab option.

Fabrication

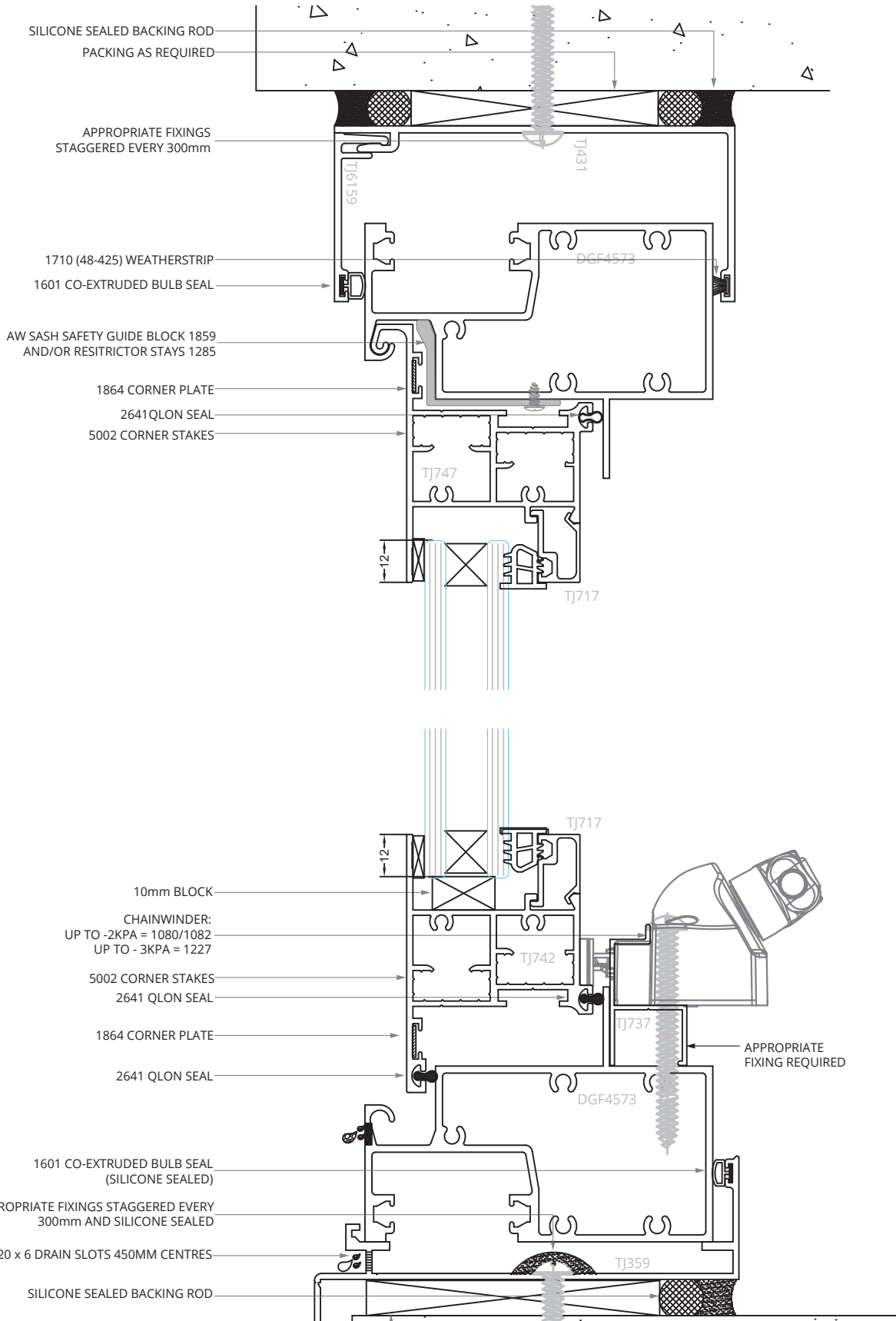

See also: Disclaimer and Copyright information on page 3

100mm Front Glazed - Jamb

All raw joints need to be sealed with small joint sealer or foam tab option.

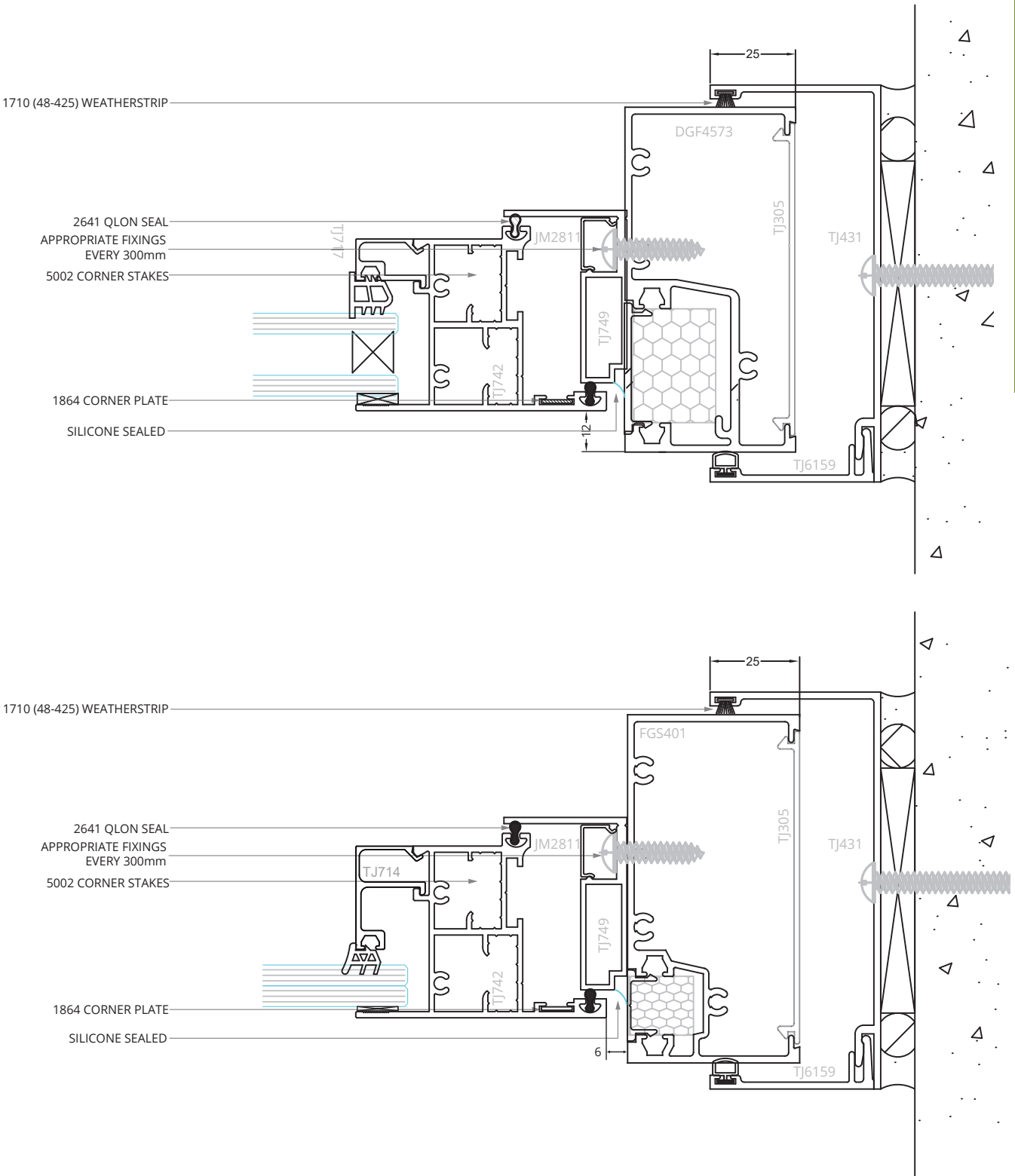

Fabrication

See also: Disclaimer and Copyright information on page 3

100mm Front Glazed - Transom

All raw joints need to be sealed with small joint sealer or foam tab option.

Fabrication

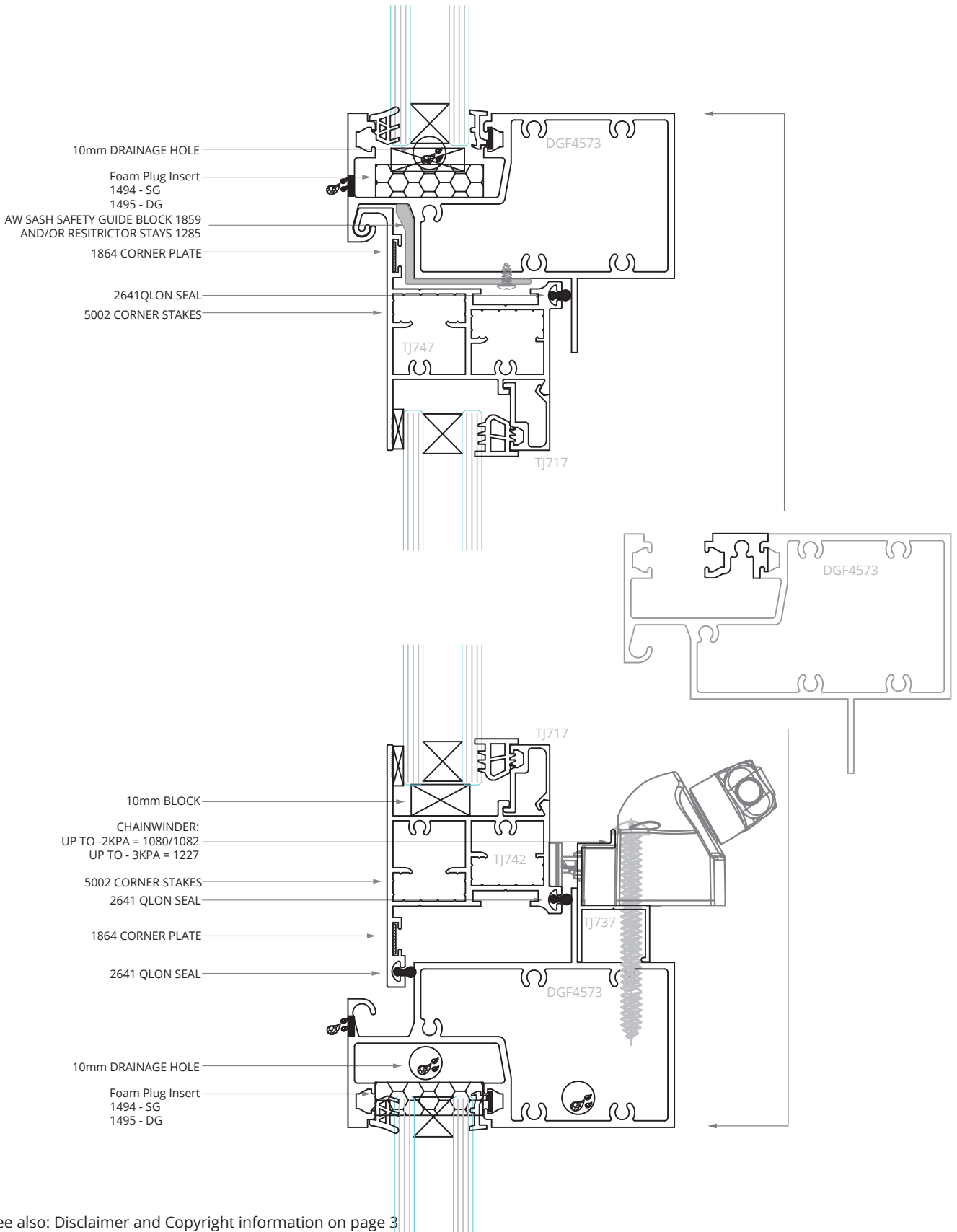

See also: Disclaimer and Copyright information on page 3

100mm Front Glazed - Awning Over Awning

All raw joints need to be sealed with small joint sealer or foam tab option.

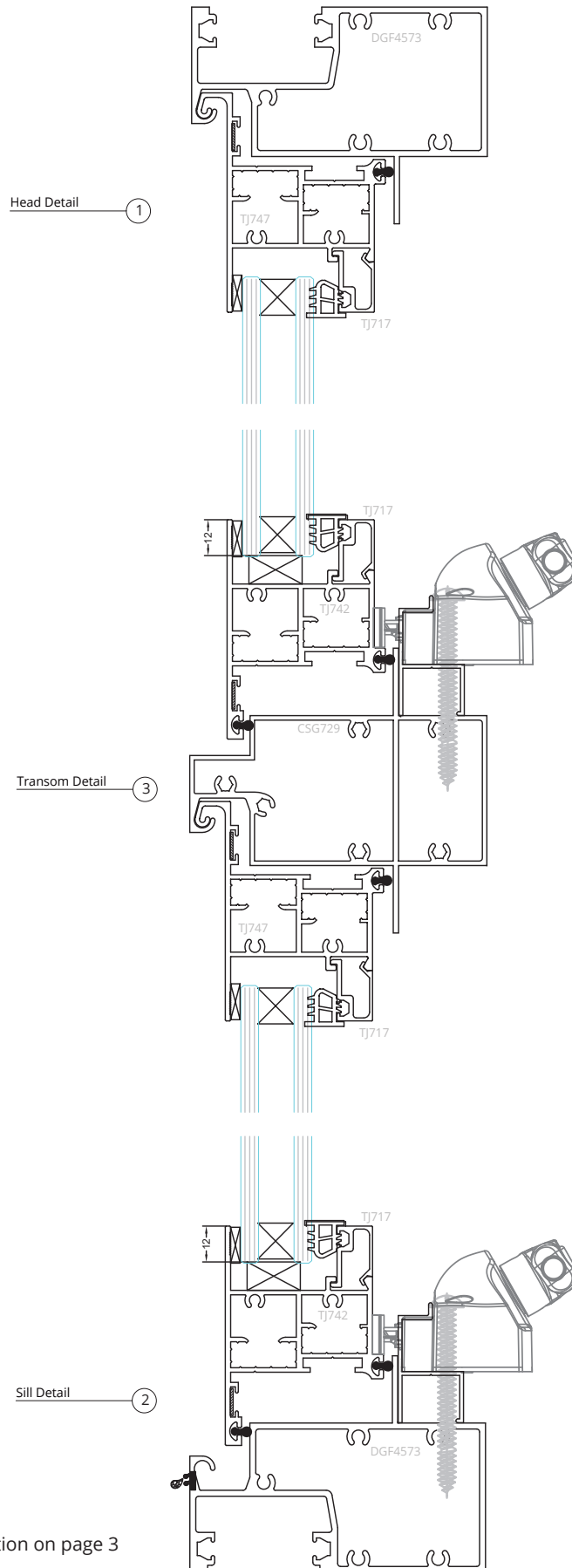

Fabrication

See also: Disclaimer and Copyright information on page 3

150mm Centre Glazed

All raw joints need to be sealed with small joint sealer or foam tab option.

Fabrication

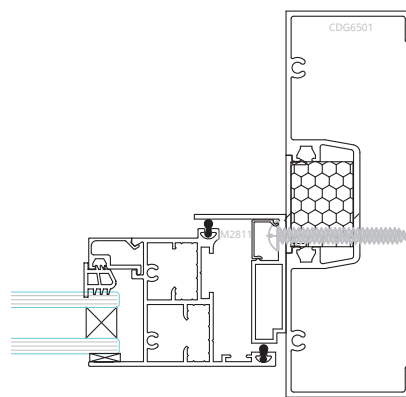
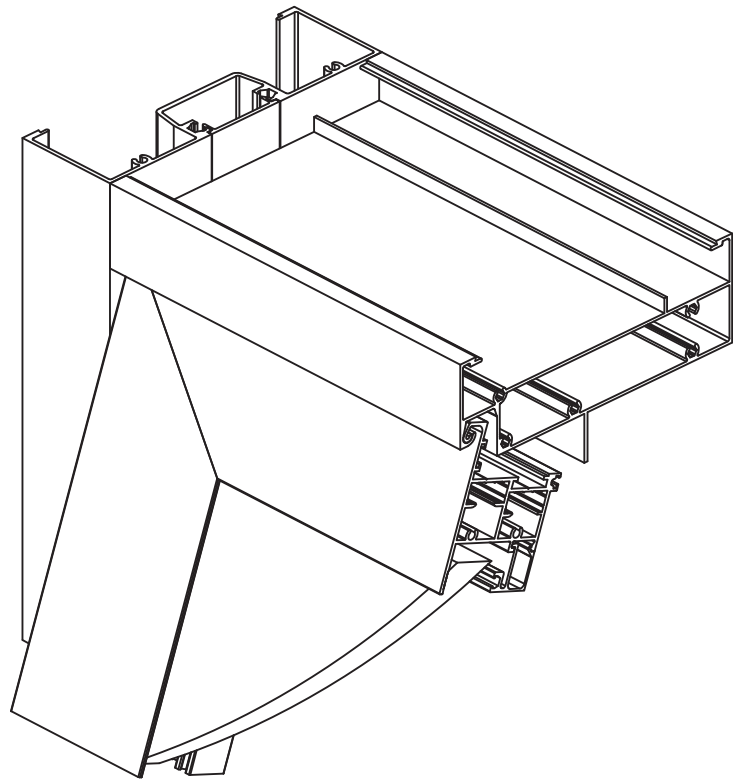
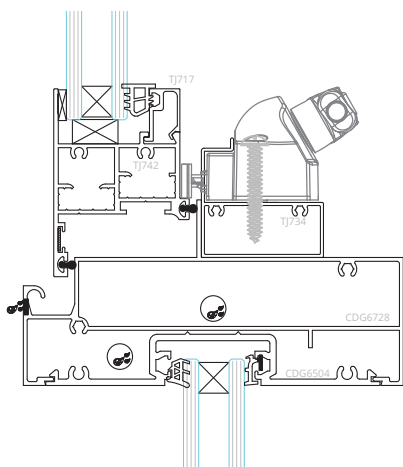
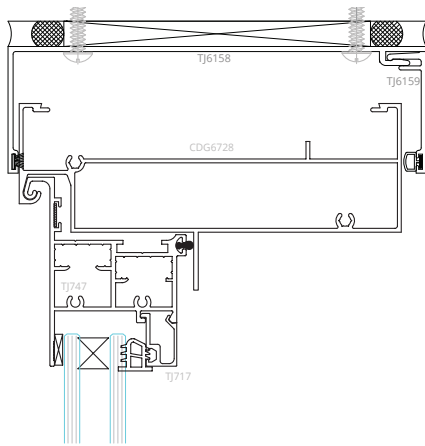

See also: Disclaimer and Copyright information on page 3

150mm Centre Glazed - Head/Sill

All raw joints need to be sealed with small joint sealer or foam tab option.

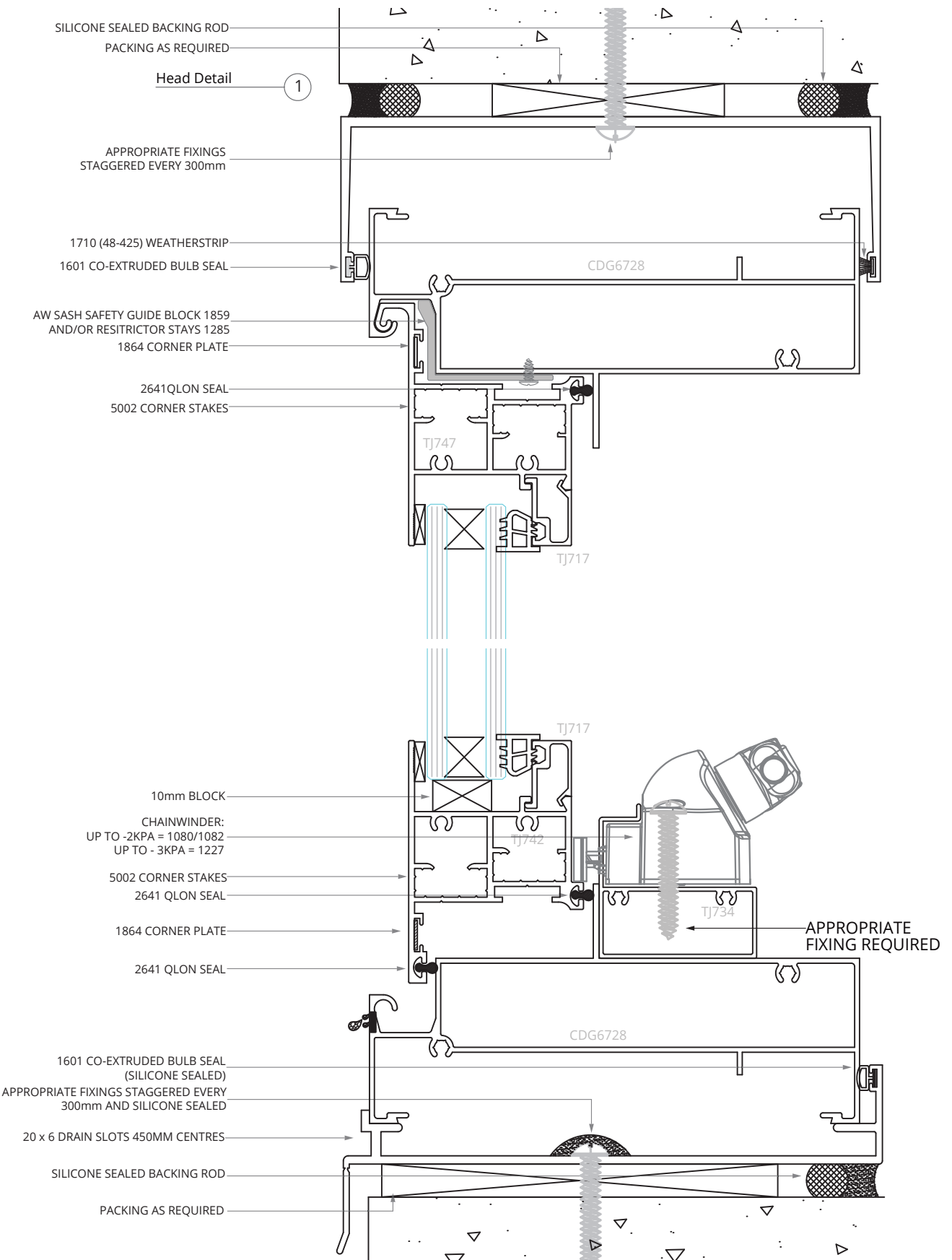

Fabrication

See also: Disclaimer and Copyright information on page 3

150mm Centre Glazed - Jamb

All raw joints need to be sealed with small joint sealer or foam tab option.

Fabrication

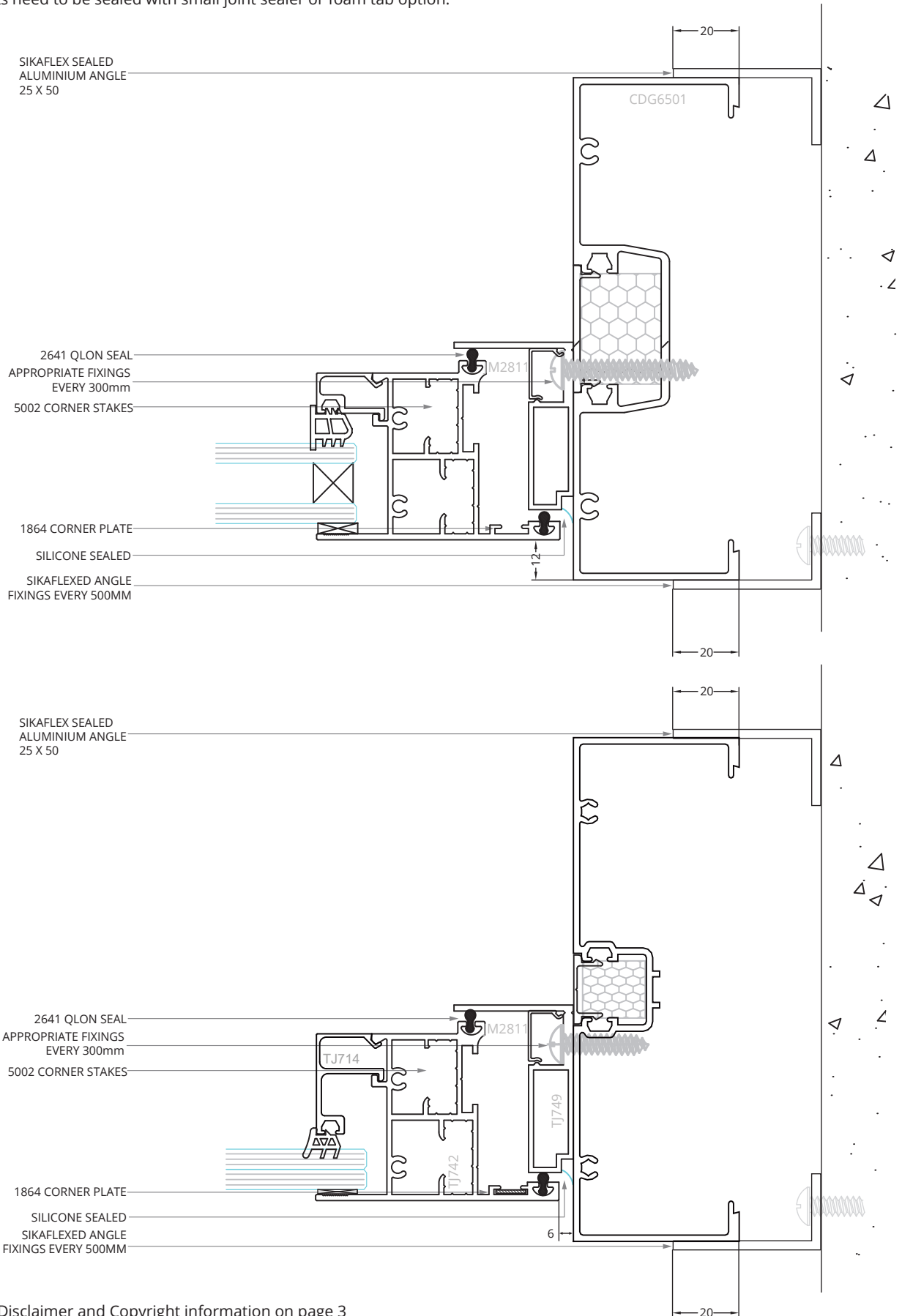

See also: Disclaimer and Copyright information on page 3

150mm Centre Glazed - Transom

All raw joints need to be sealed with small joint sealer or foam tab option.

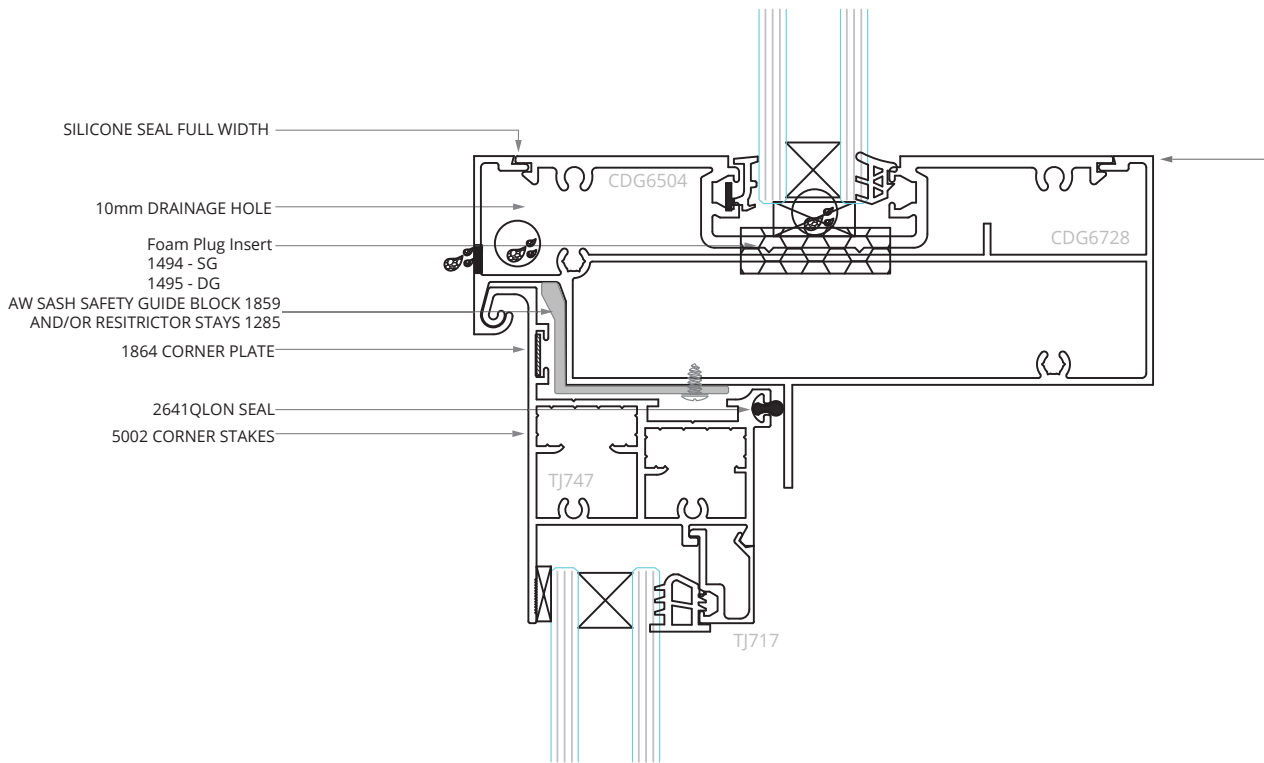

Fabrication

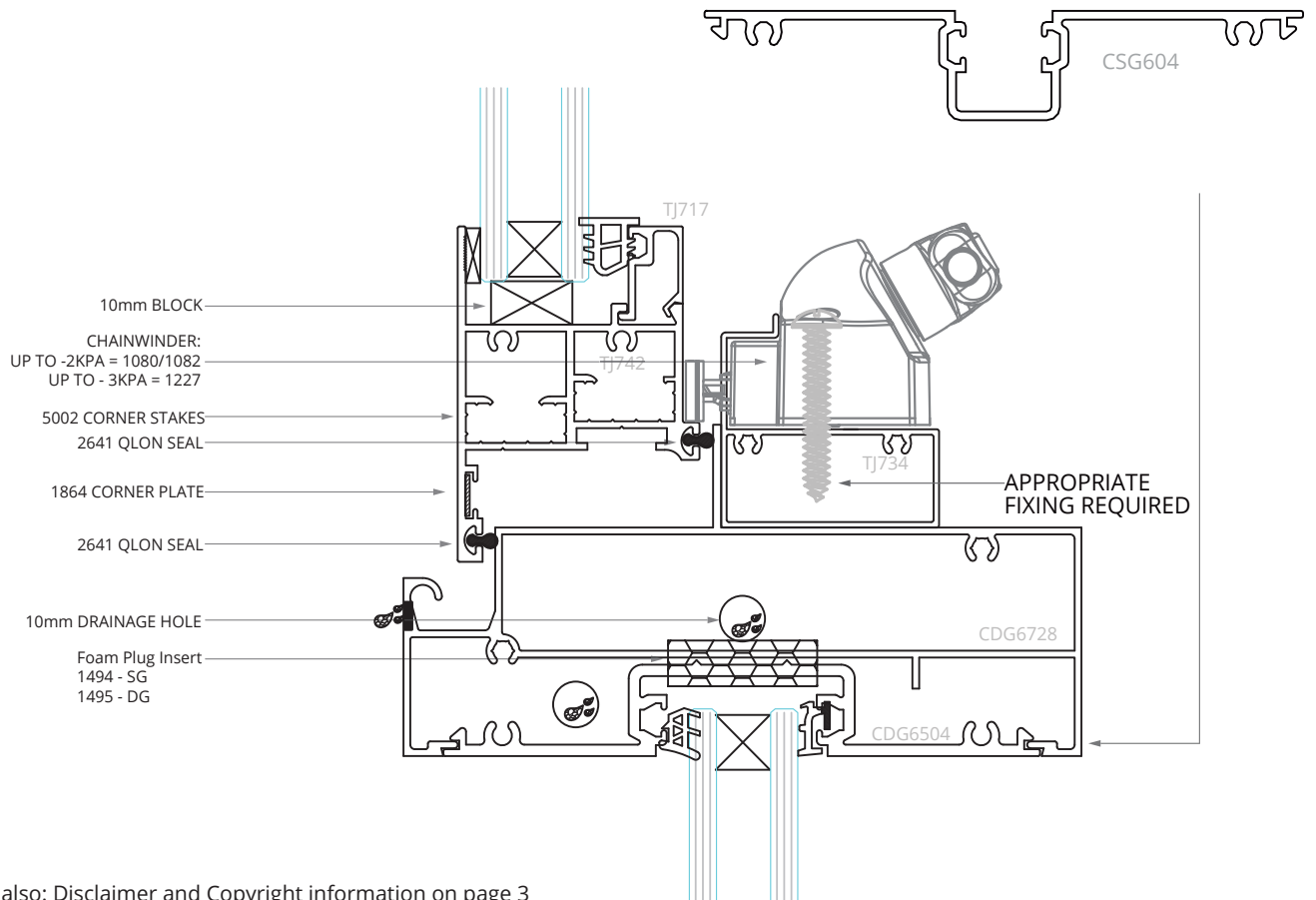

See also: Disclaimer and Copyright information on page 3

50MM HOOK AWNING

150mm Front Glazed

All raw joints need to be sealed with small joint sealer or foam tab option.

Fabrication

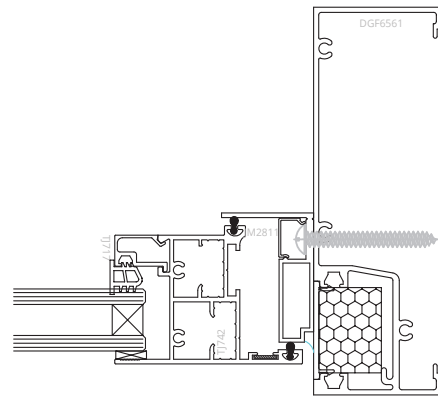
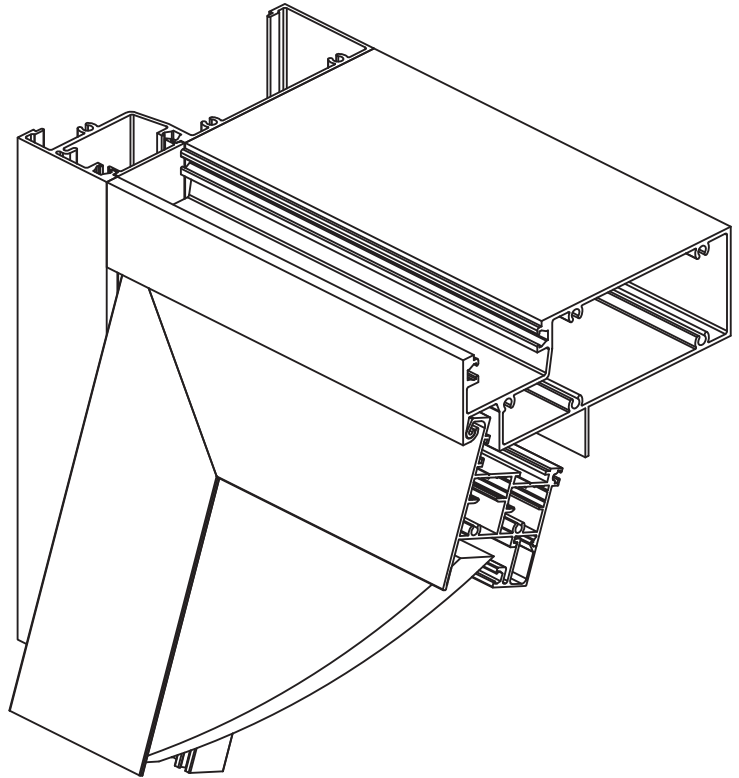
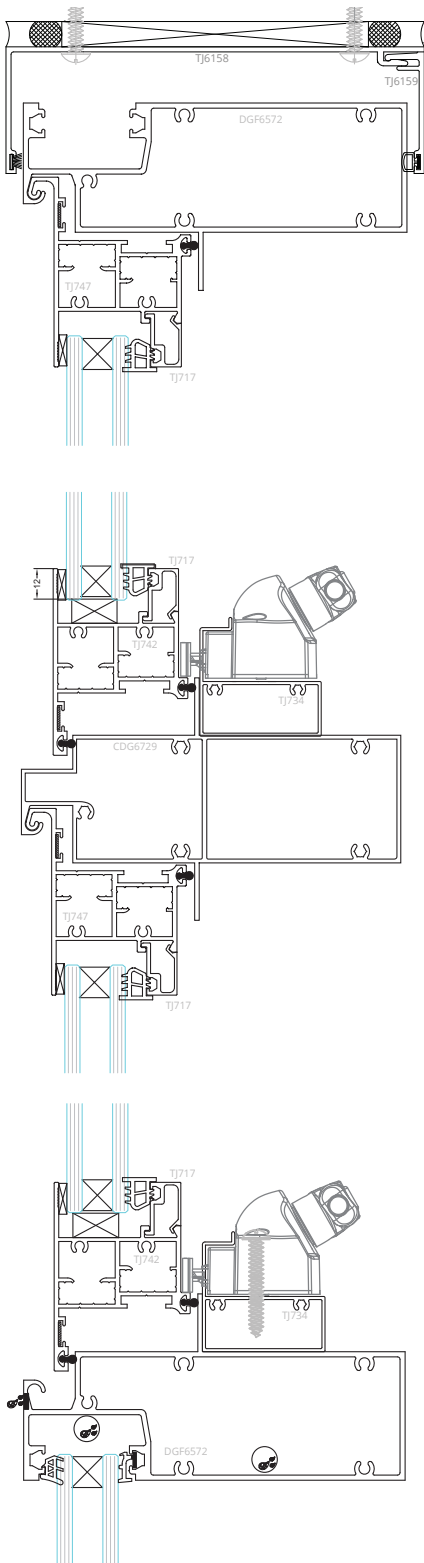

See also: Disclaimer and Copyright information on page 3

150mm Front Glazed - Head/Sill

All raw joints need to be sealed with small joint sealer or foam tab option.

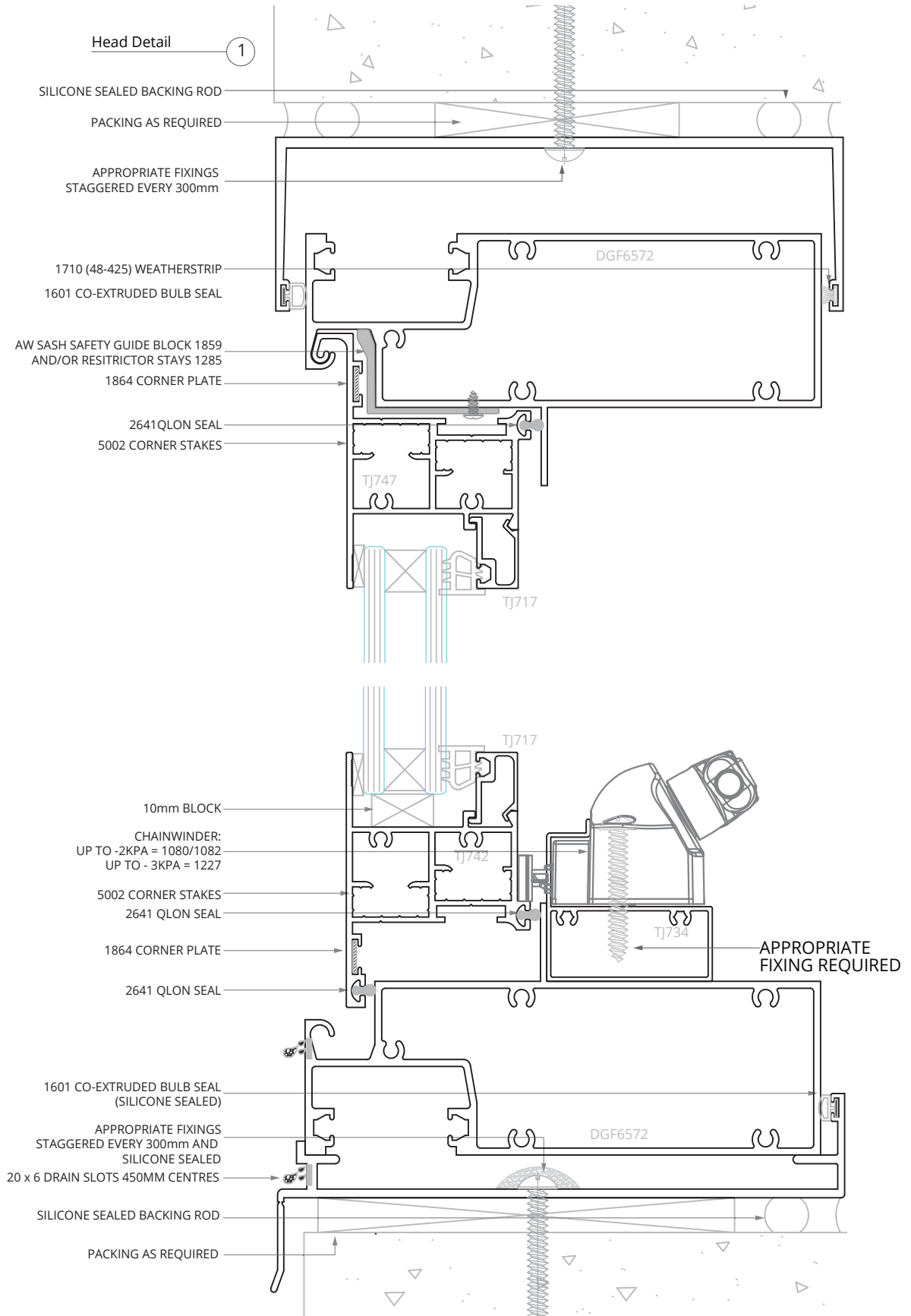

Fabrication

See also: Disclaimer and Copyright information on page 3

150mm Front Glazed - Jamb

All raw joints need to be sealed with small joint sealer or foam tab option.

Fabrication

Jamb Detail (5)

SIKAFLEX SEALED ALUMINIUM ANGLE 25 X 50

2641 QLON SEAL
APPROPRIATE FIXINGS EVERY 300mm
5002 CORNER STAKES

INSIDE
OUTSIDE

1864 CORNER PLATE
SILICONE SEALED
SIKAFLEXED ANGLE
FIXINGS EVERY 500MM

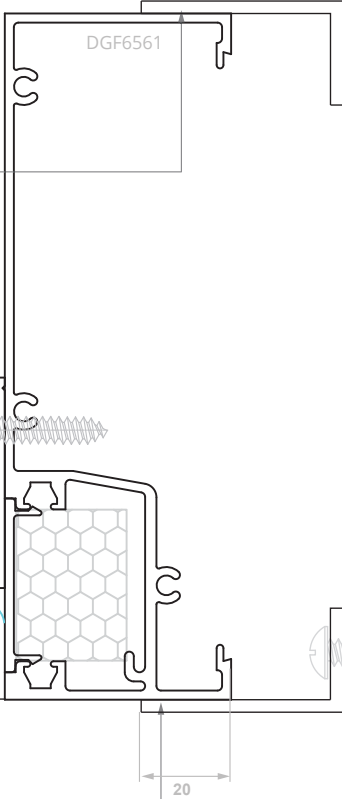

Jamb Detail (X)

SIKAFLEX SEALED ALUMINIUM ANGLE 25 X 50

2641 QLON SEAL
APPROPRIATE FIXINGS EVERY 300mm
5002 CORNER STAKES
SILICONE SEALED

INSIDE
OUTSIDE

1864 CORNER PLATE
2641 QLON SEAL
SIKAFLEXED ANGLE
FIXINGS EVERY 500MM

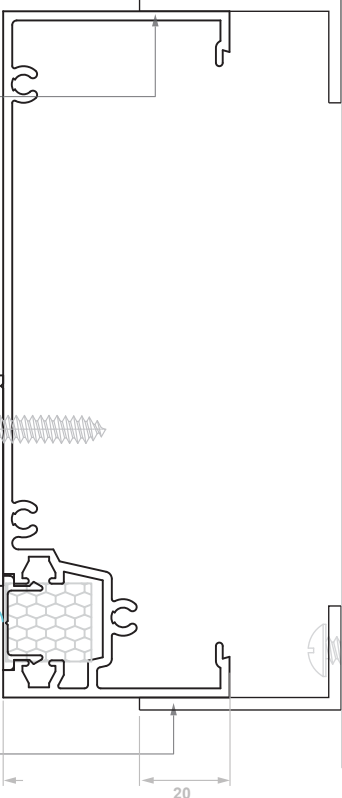

See also: Disclaimer and Copyright information on page 3

150mm Front Glazed - Transom

All raw joints need to be sealed with small joint sealer or foam tab option.

Fabrication

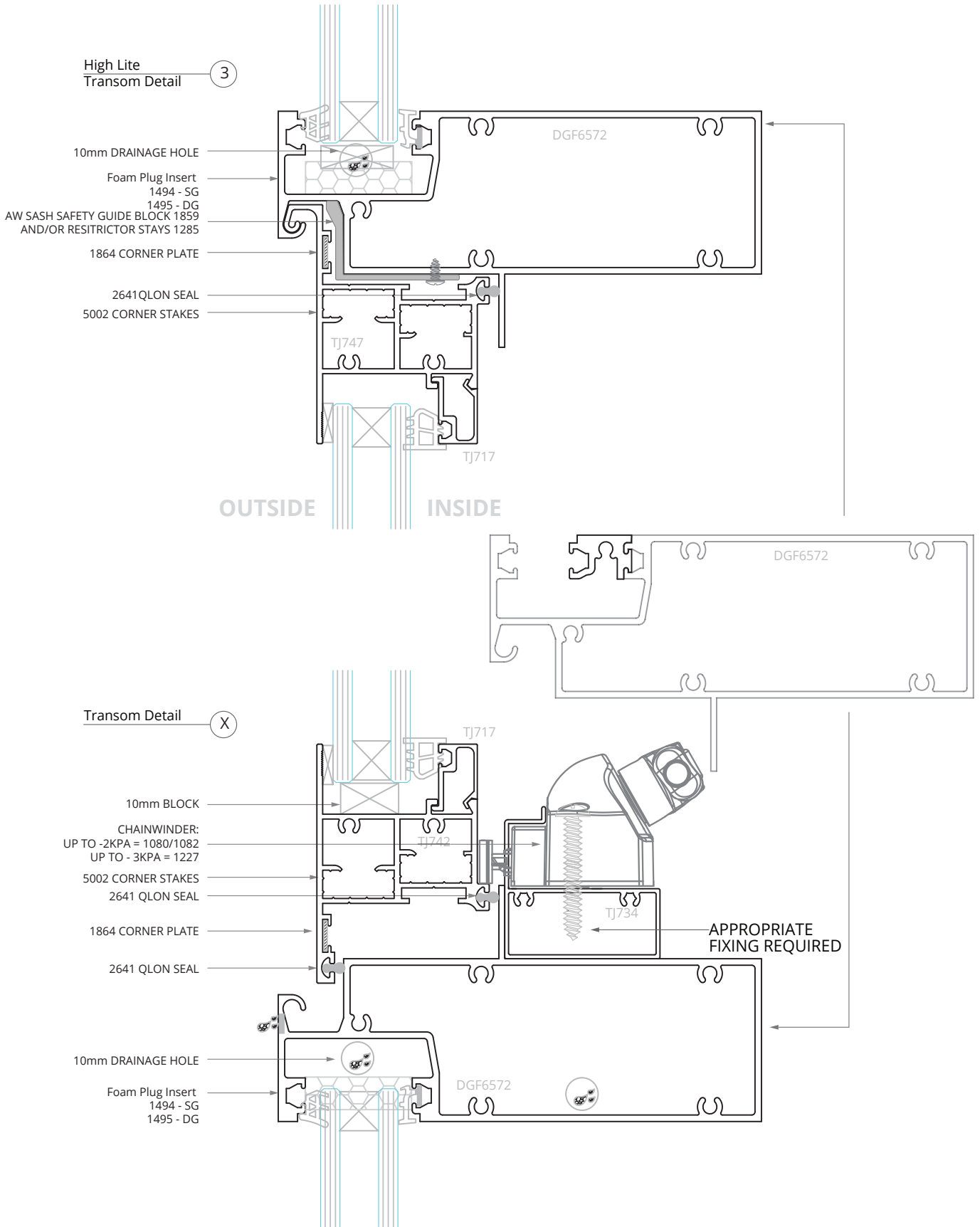

See also: Disclaimer and Copyright information on page 3

150mm Front Glazed - Awning Over Awning

All raw joints need to be sealed with small joint sealer or foam tab option.

Fabrication

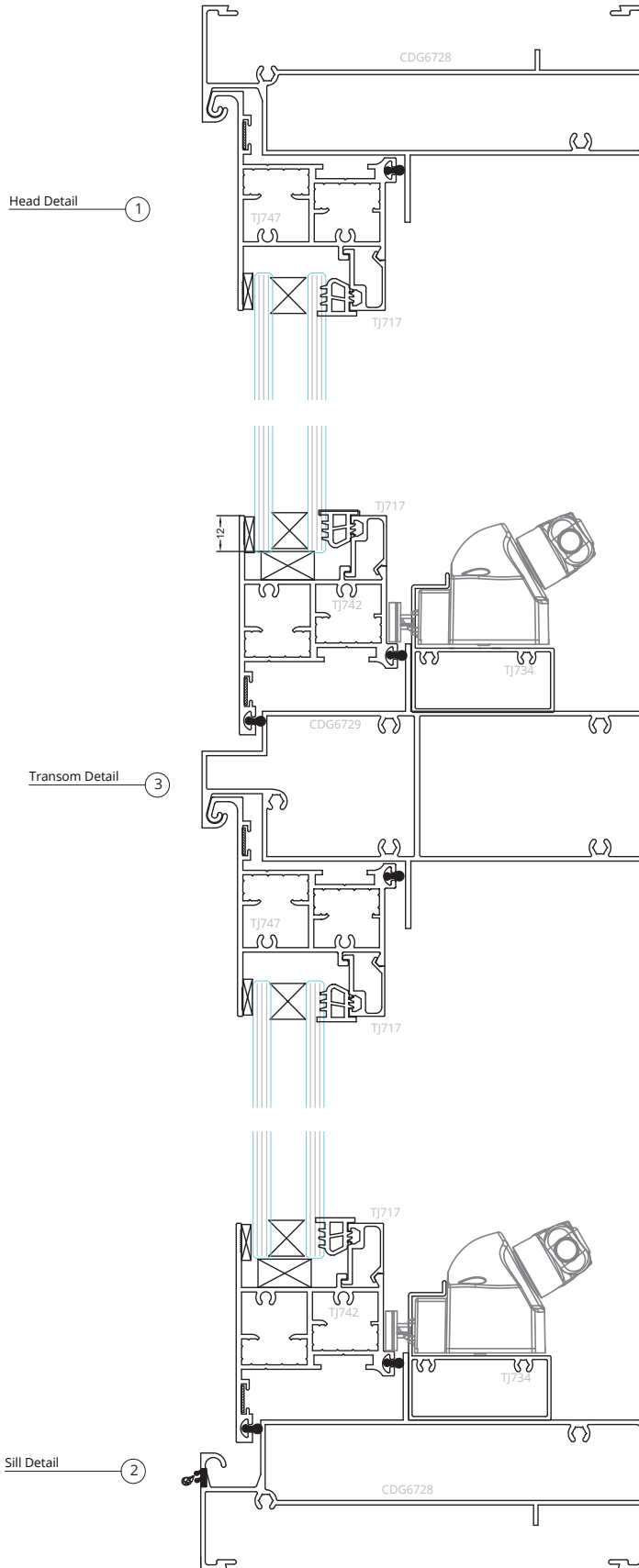

See also: Disclaimer and Copyright information on page 3

Hardware Options - Multipoint Head/Sill

All raw joints need to be sealed with small joint sealer or foam tab option.

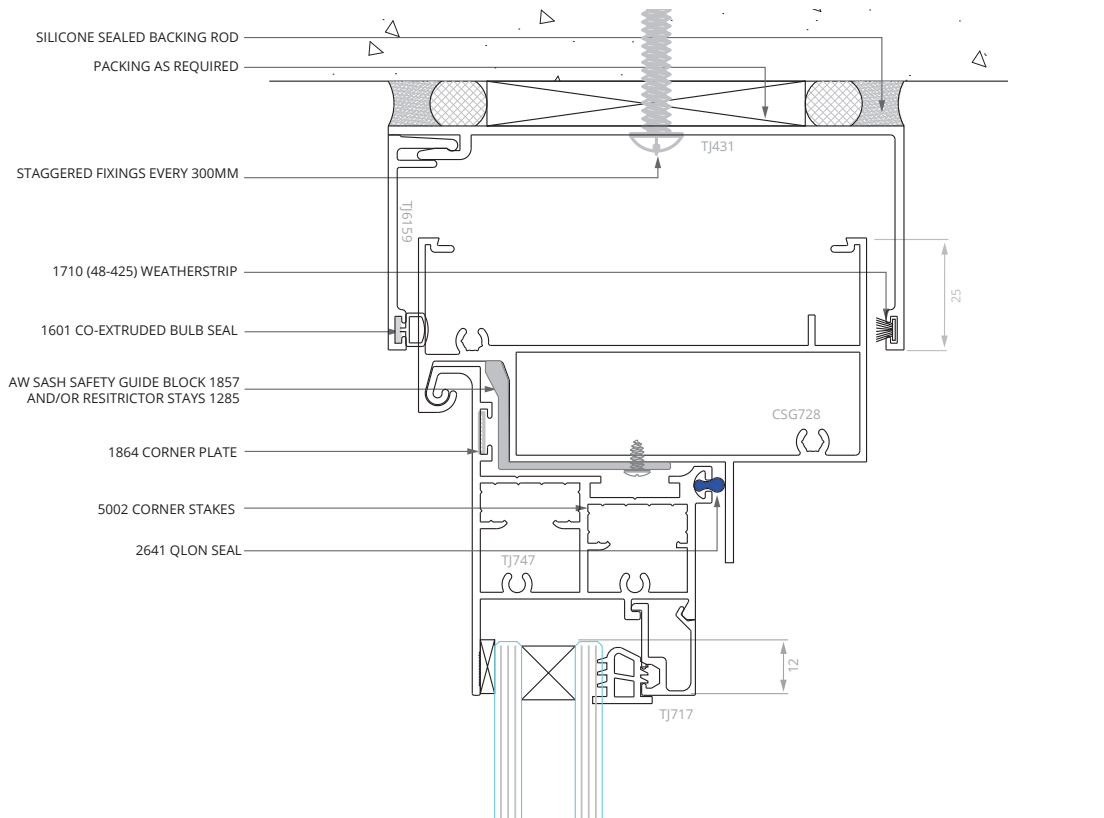

Sill Detail

2

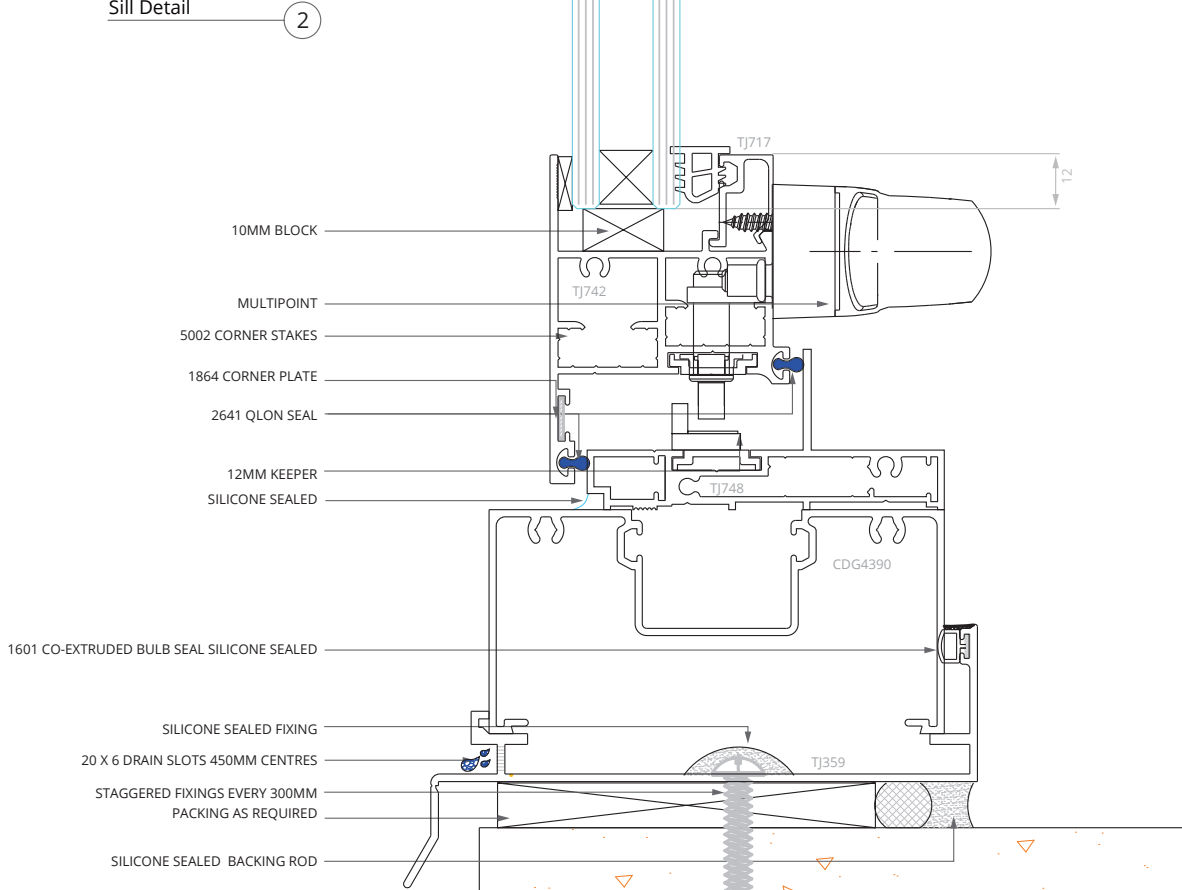

See also: Disclaimer and Copyright information on page 3

Fabrication

Hardware Options - Multipoint Transom

All raw joints need to be sealed with small joint sealer or foam tab option.

Fabrication

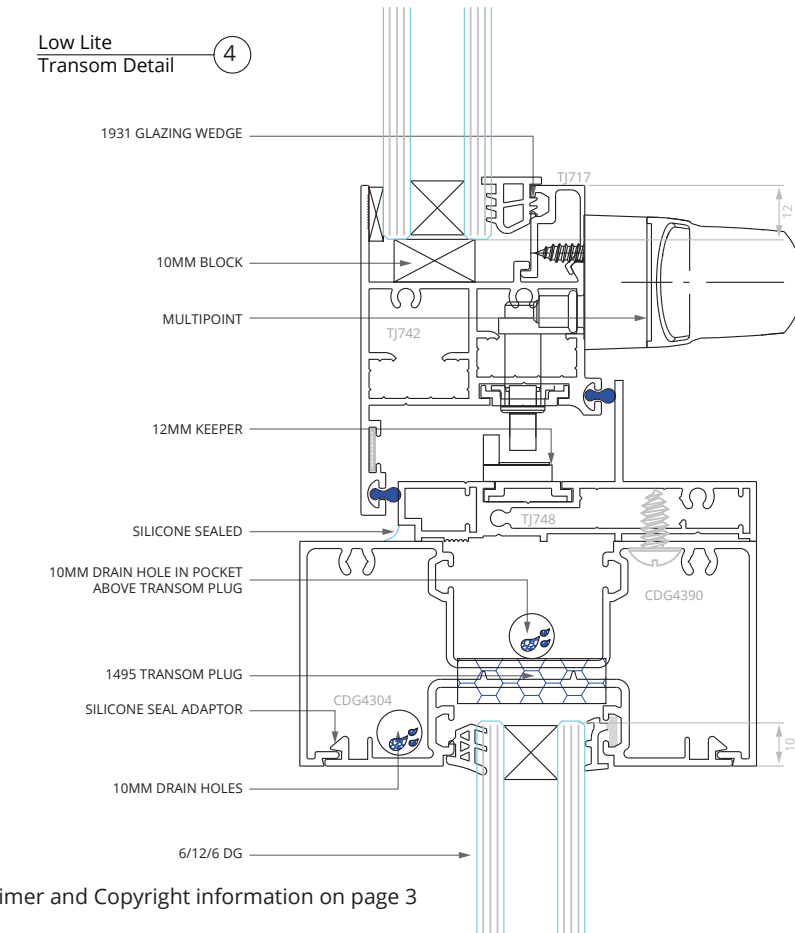
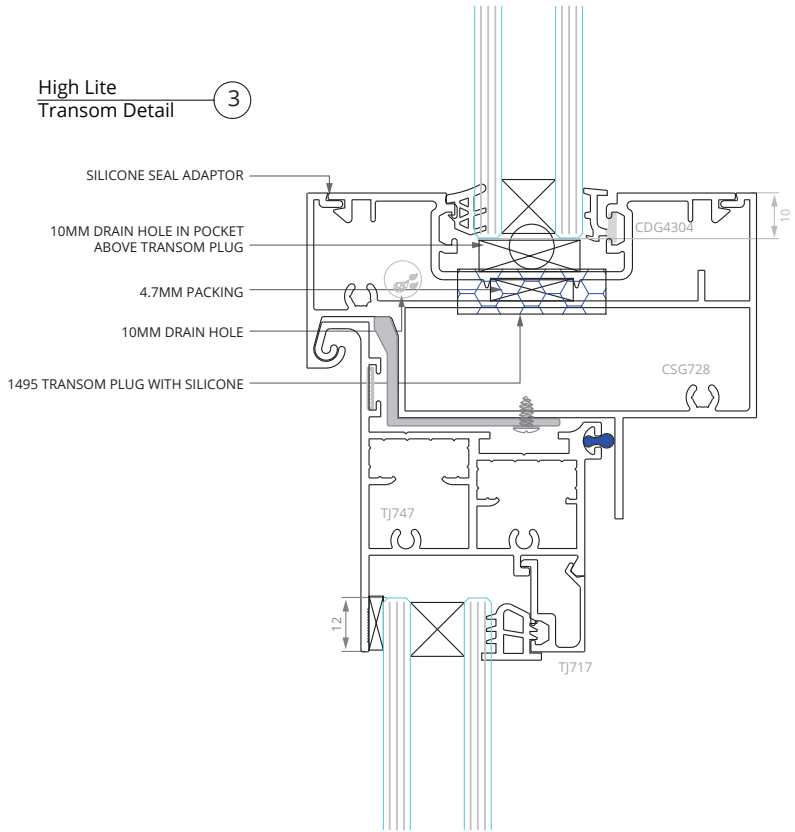

See also: Disclaimer and Copyright information on page 3

Hardware Options - Multipoint Jamb

All raw joints need to be sealed with small joint sealer or foam tab option.

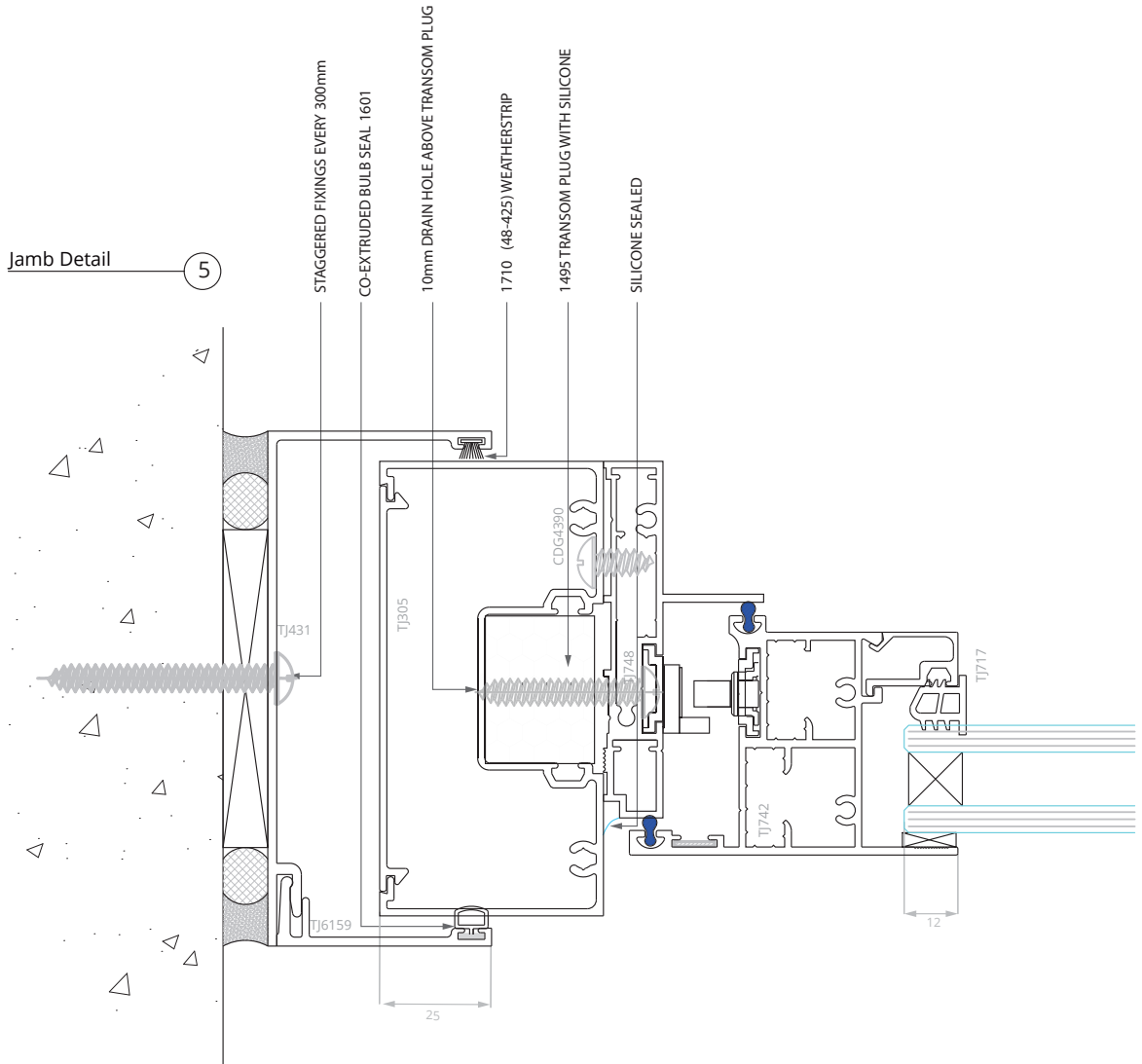

Fabrication

See also: Disclaimer and Copyright information on page 3

Hardware Options - Plant-On Multipoint Head/Sill

All raw joints need to be sealed with small joint sealer or foam tab option.

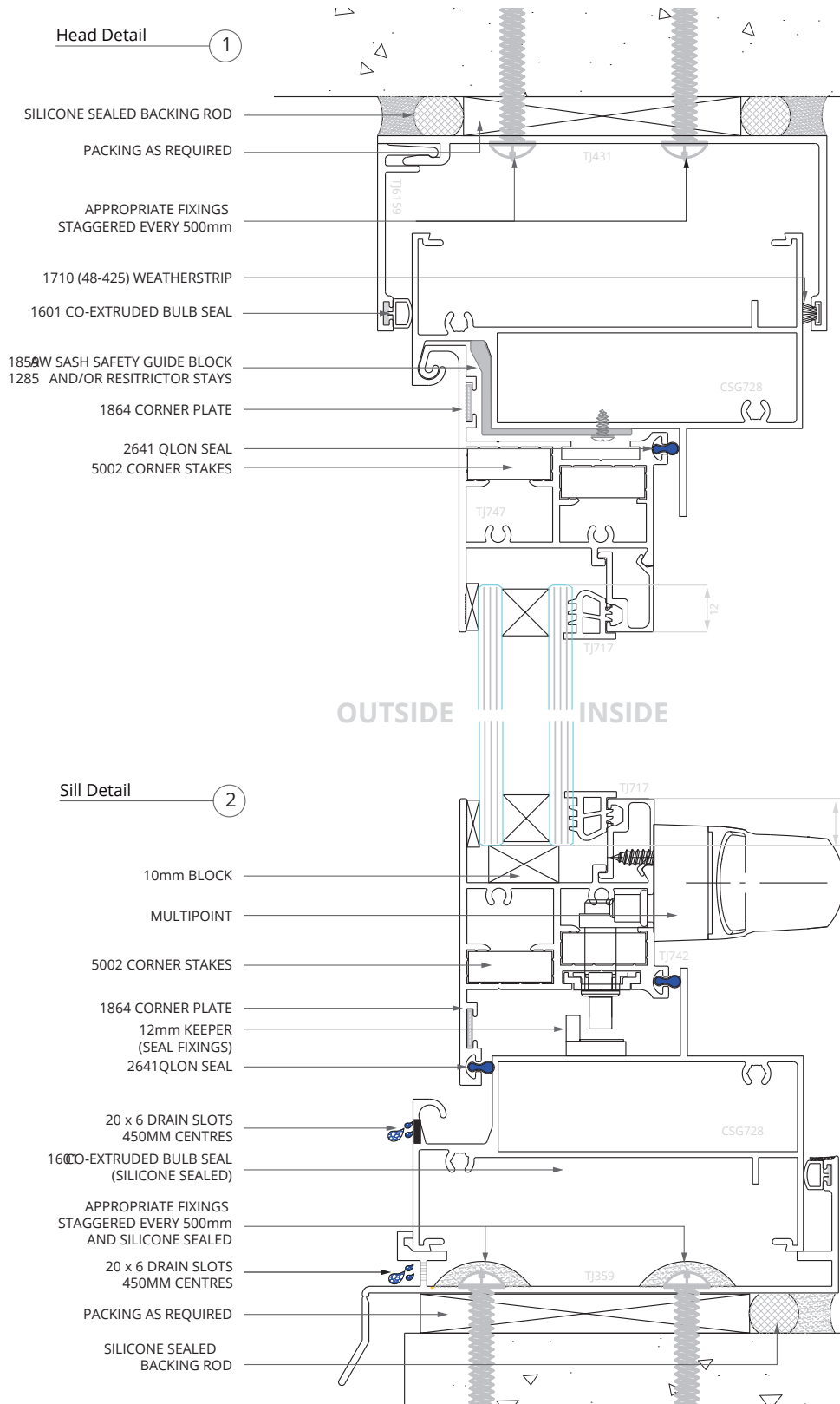

See also: Disclaimer and Copyright information on page 3

Hardware Options - Plant-On Multipoint Transom

All raw joints need to be sealed with small joint sealer or foam tab option.

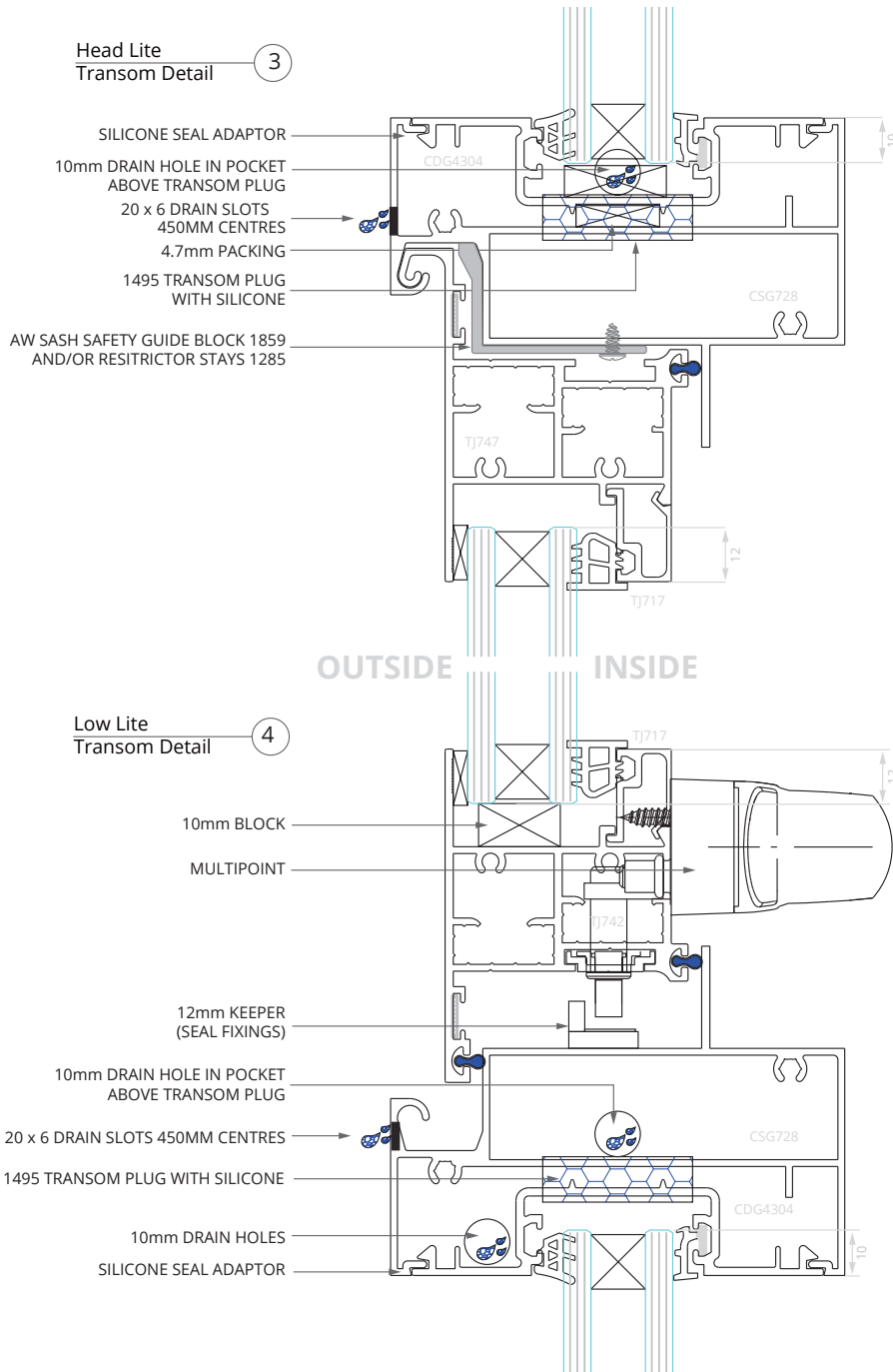

Fabrication

See also: Disclaimer and Copyright information on page 3

Hardware Options - Plant-On Multipoint Jamb

All raw joints need to be sealed with small joint sealer or foam tab option.

Fabrication

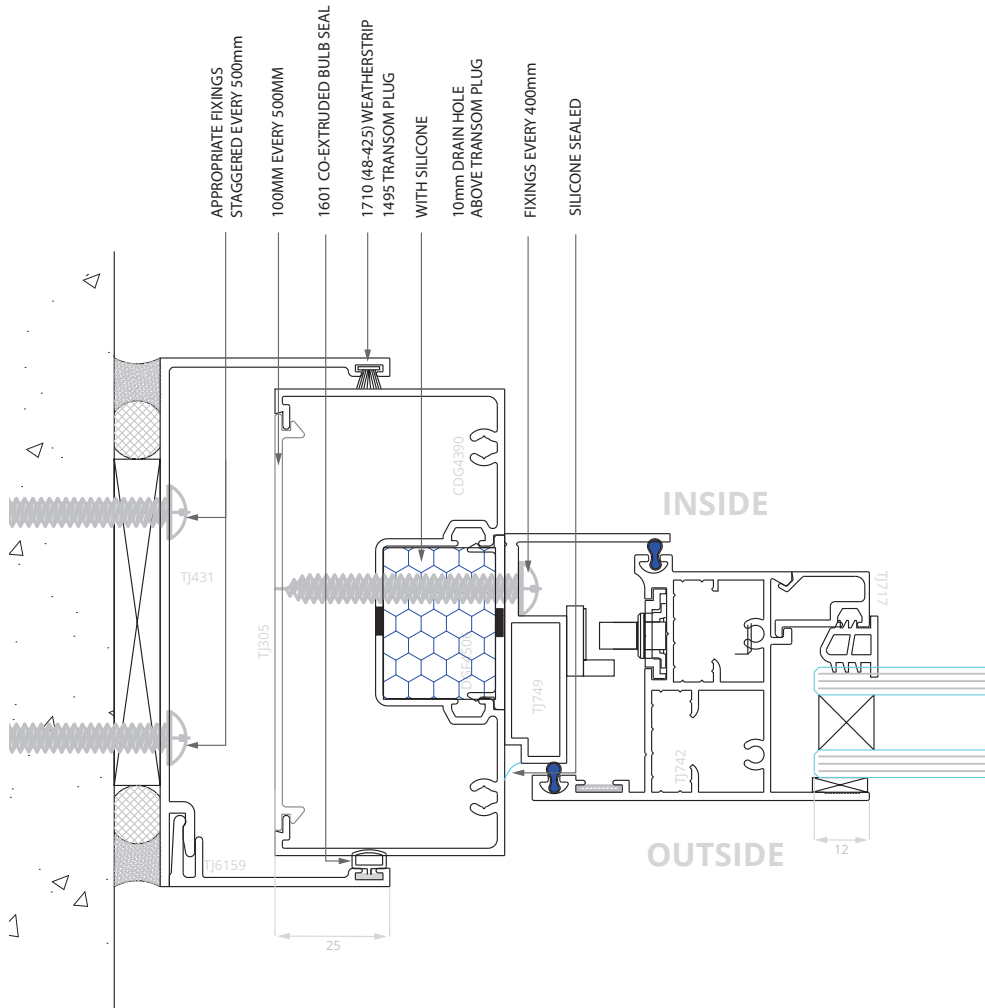

See also: Disclaimer and Copyright information on page 3

Hardware Options - Plant-On Hook Head/Sill

All raw joints need to be sealed with small joint sealer or foam tab option.

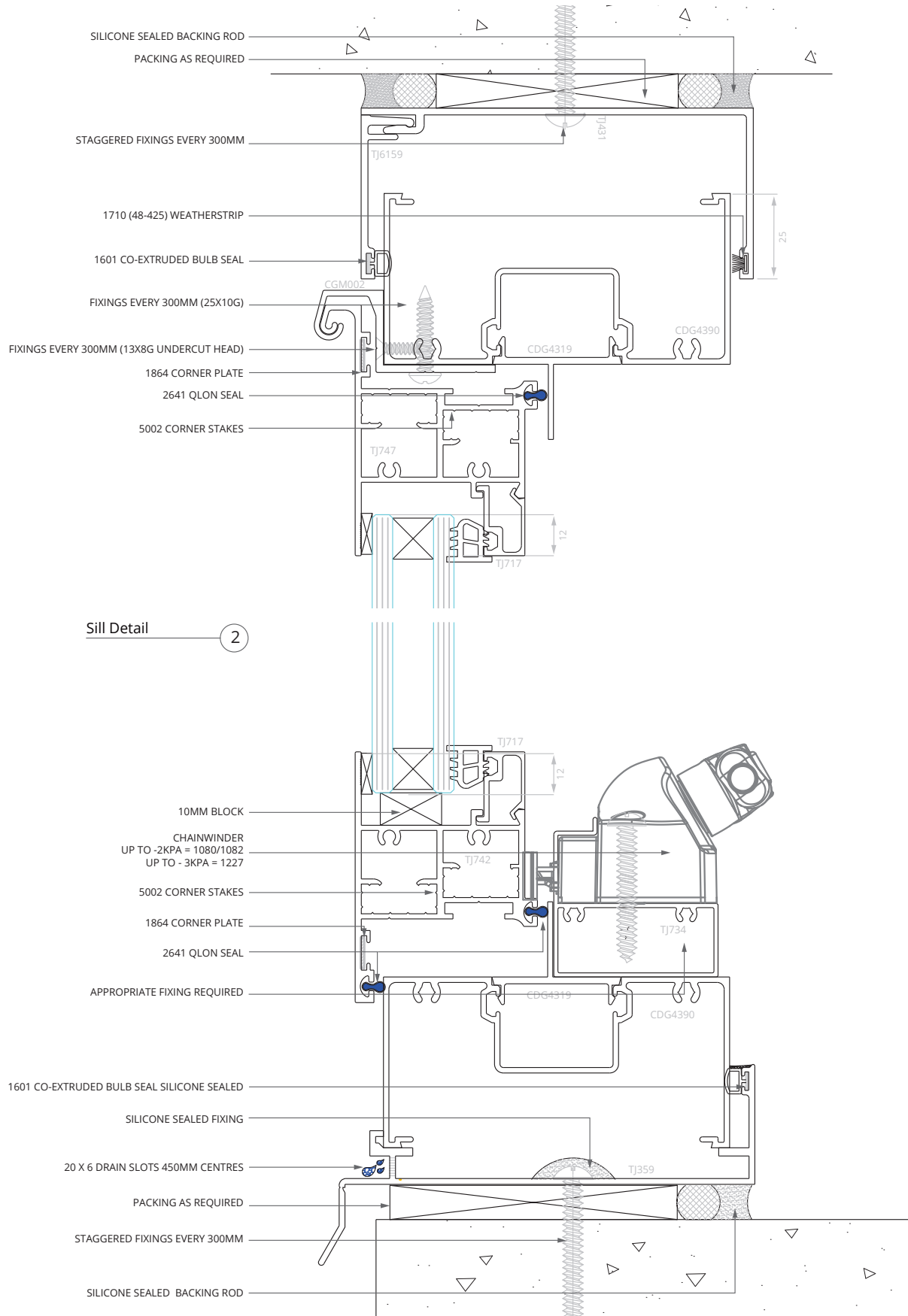

See also: Disclaimer and Copyright information on page 3

Fabrication

Hardware Options - Plant-On Hook Transom

All raw joints need to be sealed with small joint sealer or foam tab option.

Fabrication

High Lite Transom Detail 3

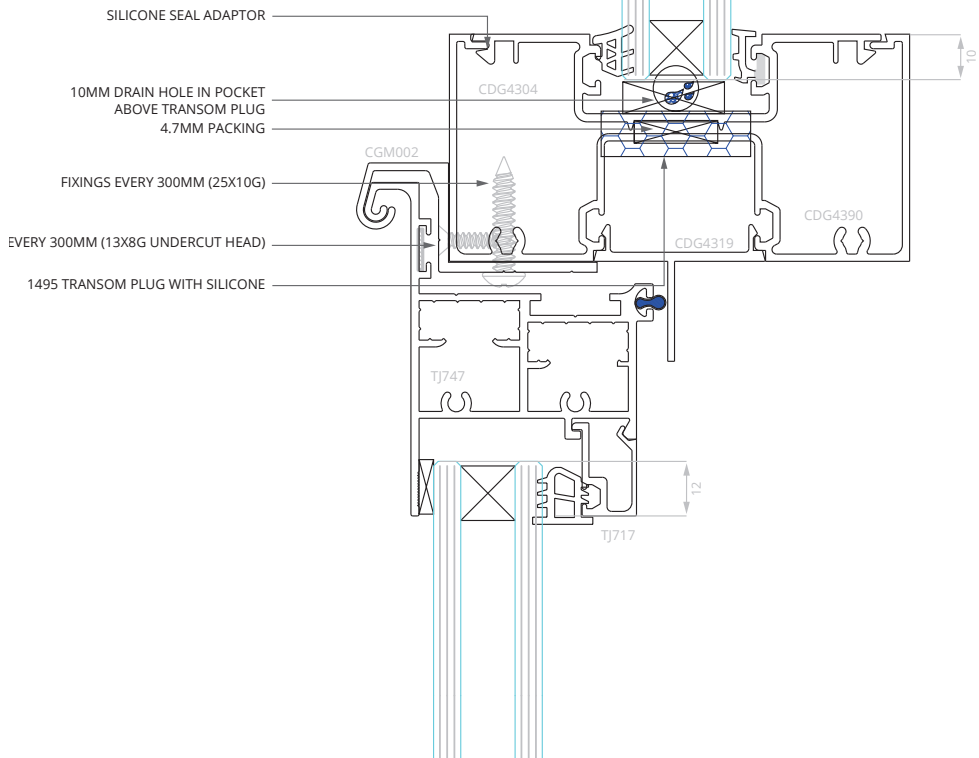

Low Lite Transom Detail 4

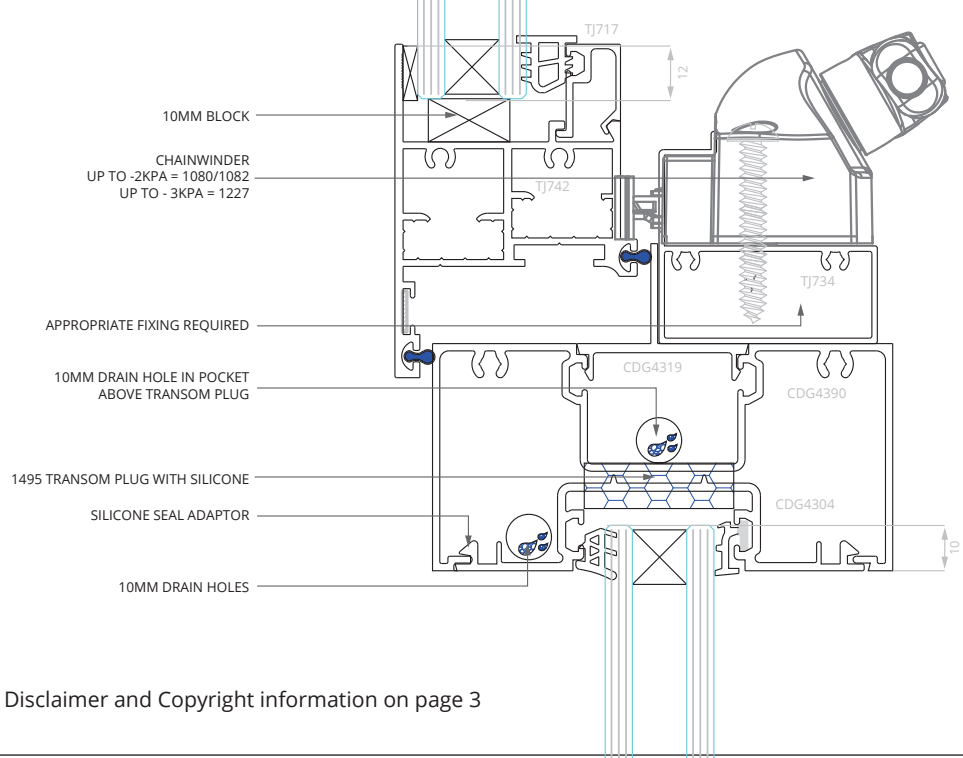

See also: Disclaimer and Copyright information on page 3

Hardware Options - Plant-On Hook Jamb

All raw joints need to be sealed with small joint sealer or foam tab option.

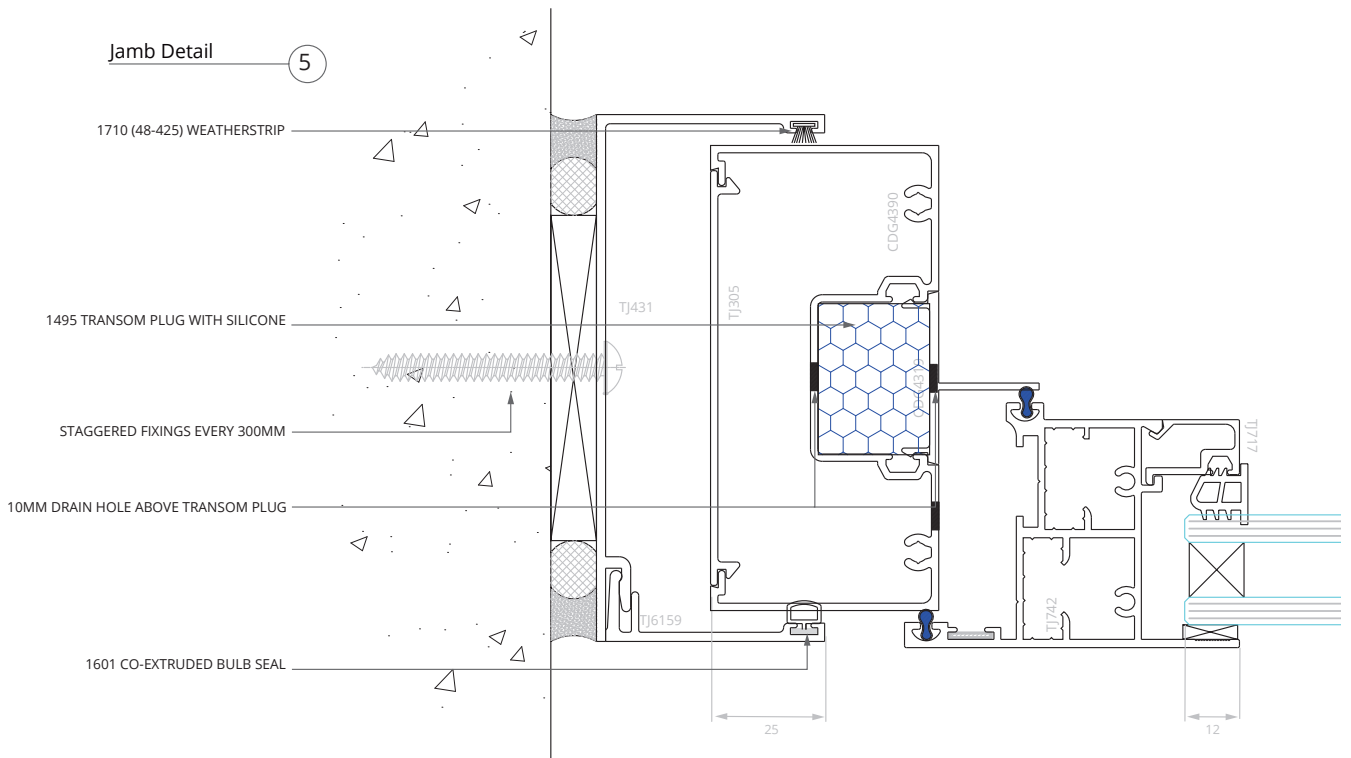

Fabrication

See also: Disclaimer and Copyright information on page 3

Hardware Options - Plant-On Hook With Plant-On Multipoint Head/Sill

All raw joints need to be sealed with small joint sealer or foam tab option.

Fabrication

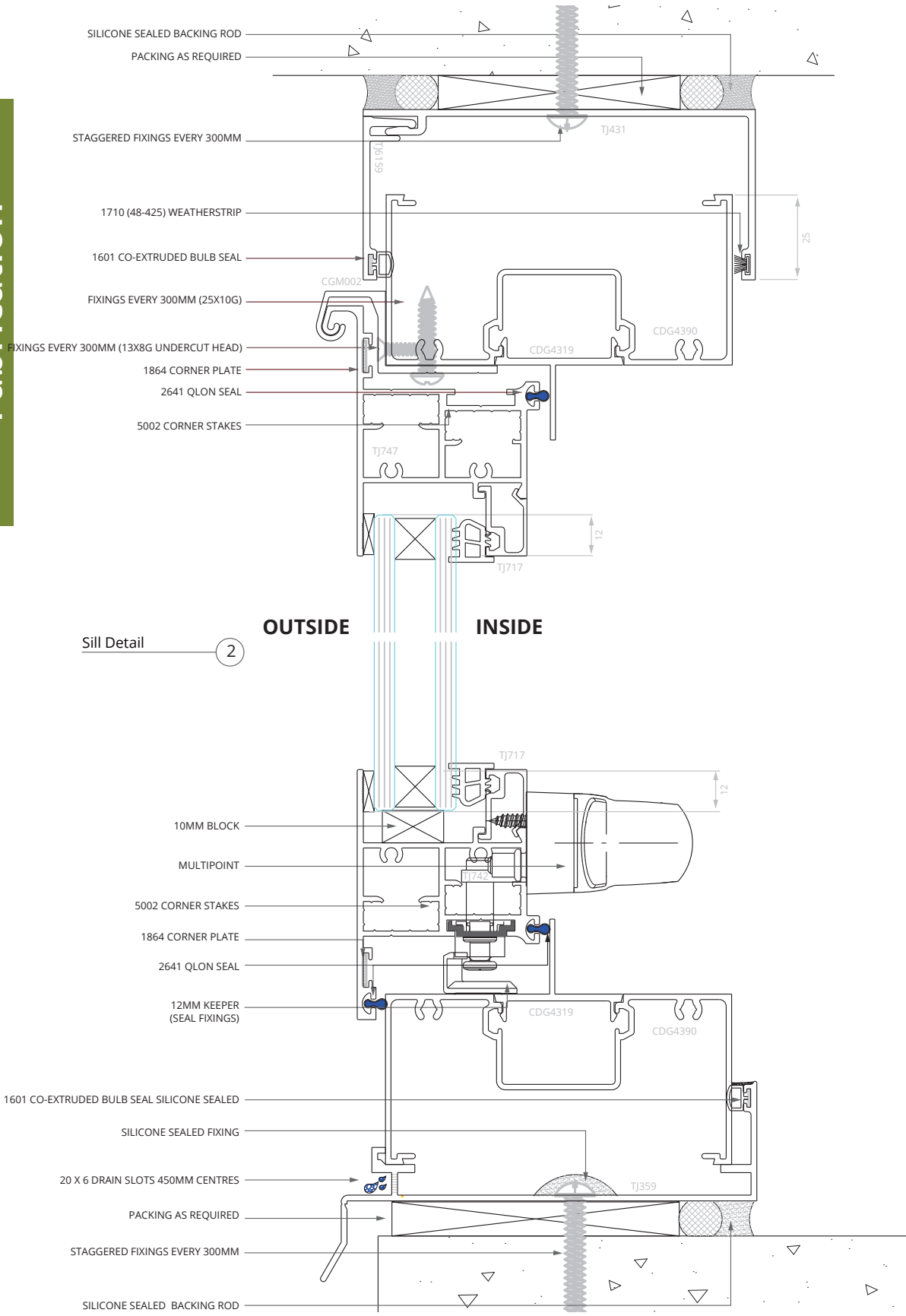

Sill Detail ②

See also: Disclaimer and Copyright information on page 3

Hardware Options - Plant-On Hook With Plant-On Multipoint Transom

All raw joints need to be sealed with small joint sealer or foam tab option.

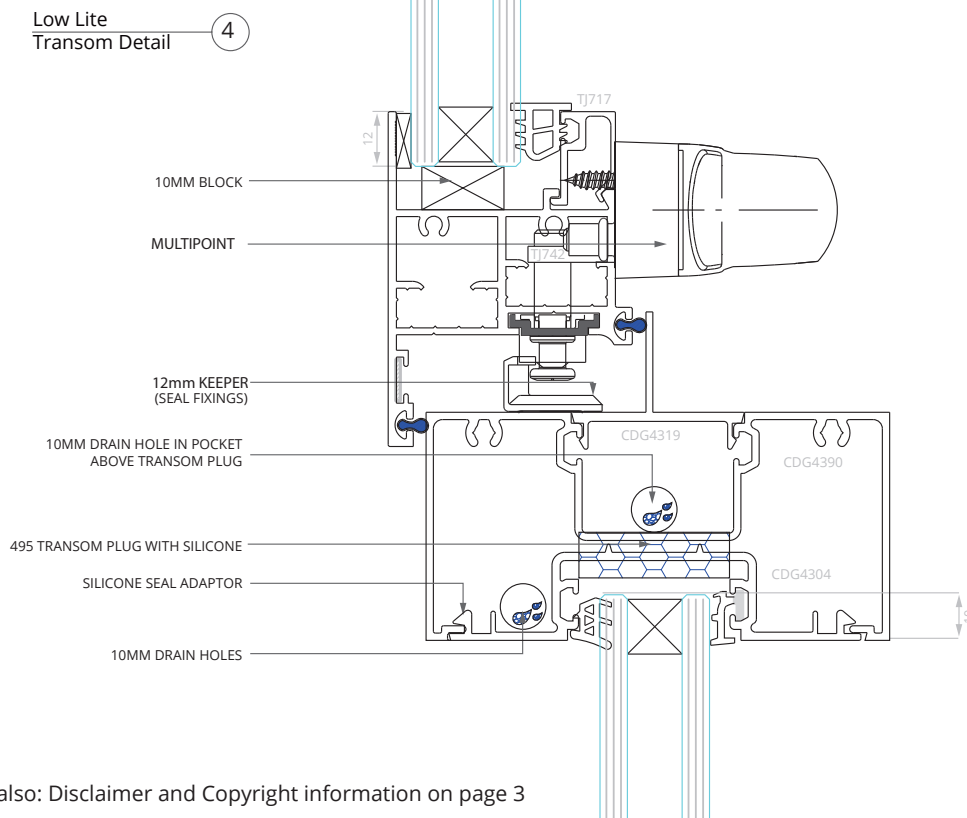
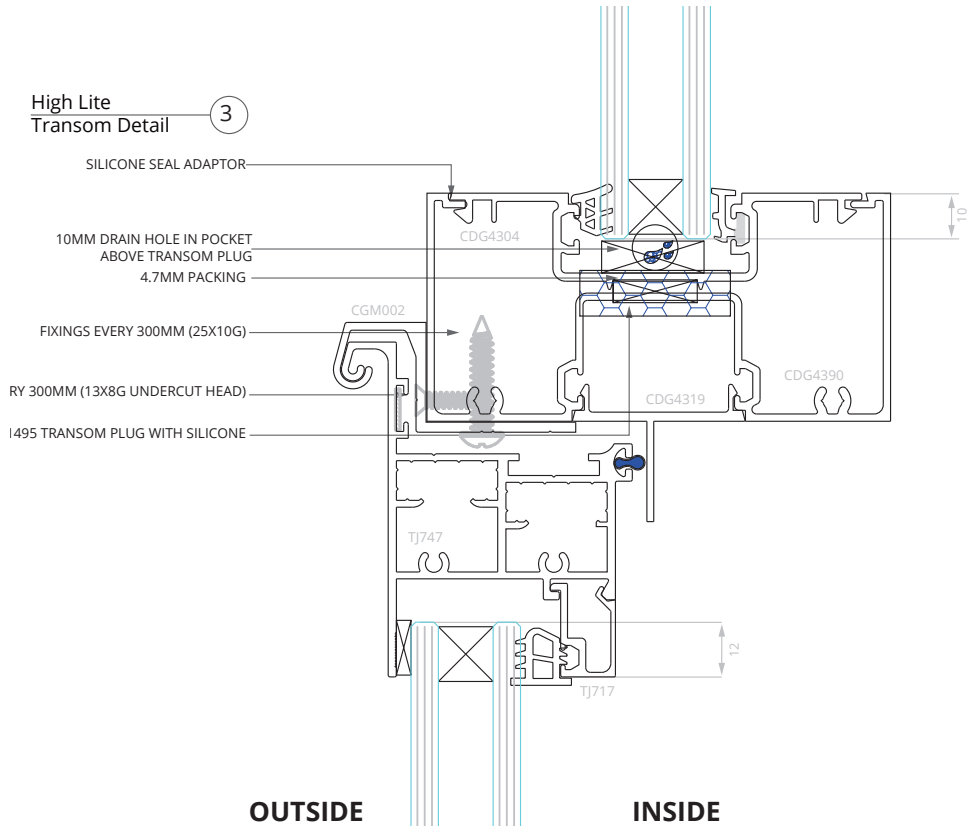

See also: Disclaimer and Copyright information on page 3

Fabrication

Hardware Options - Plant-On Hook With Plant-On Multipoint Jamb

All raw joints need to be sealed with small joint sealer or foam tab option.

Fabrication

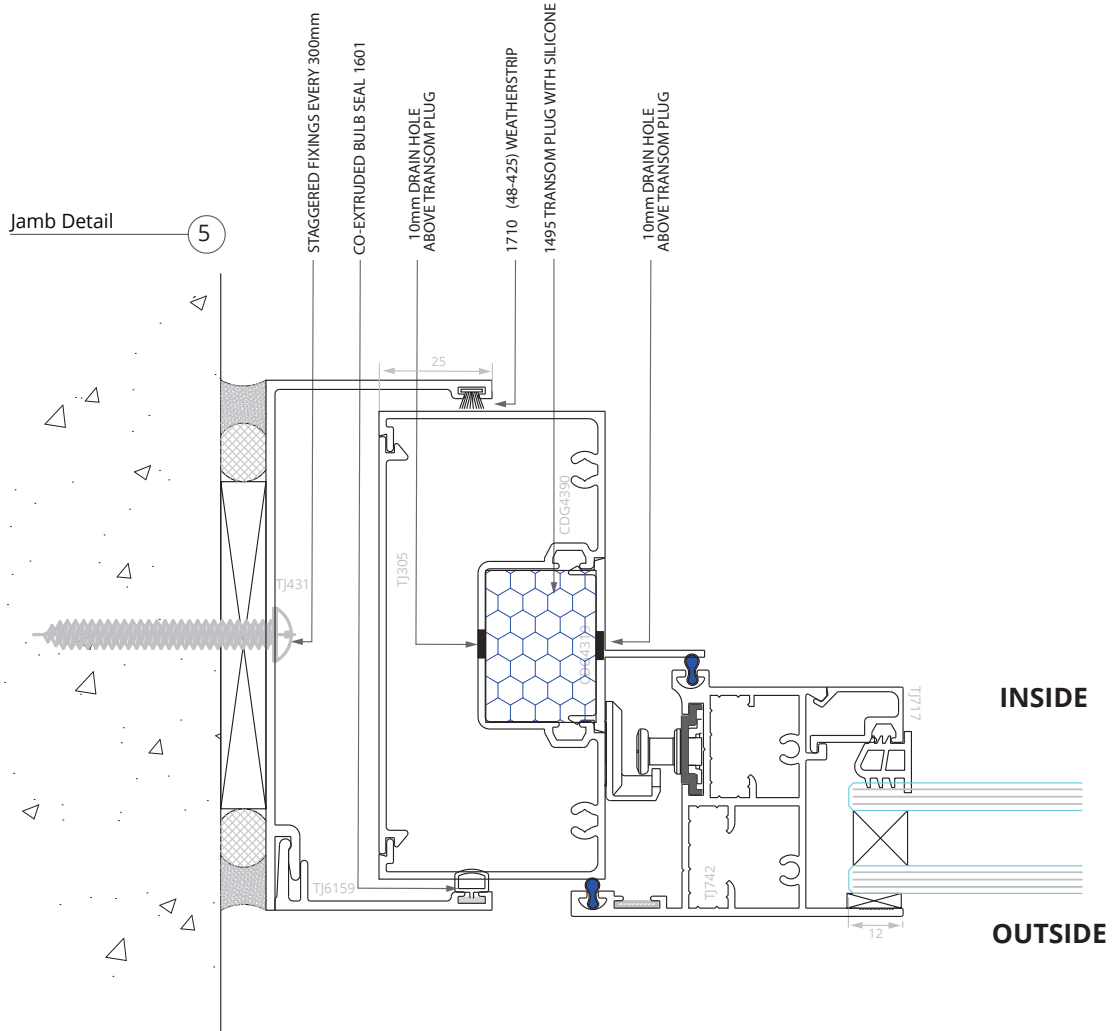

See also: Disclaimer and Copyright information on page 3

1859 Awning Sash Safety Guide Installation

All raw joints need to be sealed with small joint sealer or foam tab option.

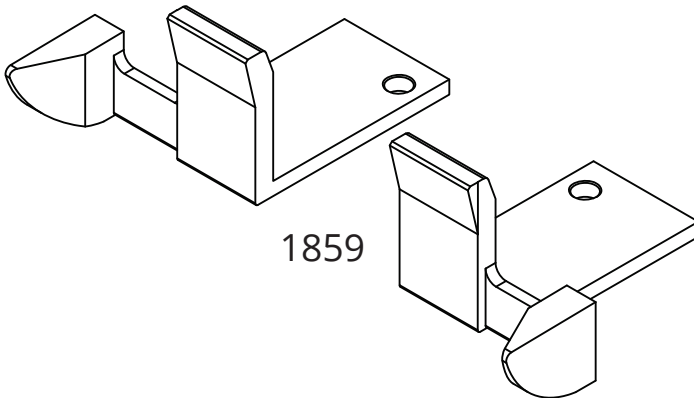

- Prevents sash from accidental disengagement
- Centres the sash

1859 has to be installed after the sash is in the frame and the sash should be in an open position at 90 degrees.

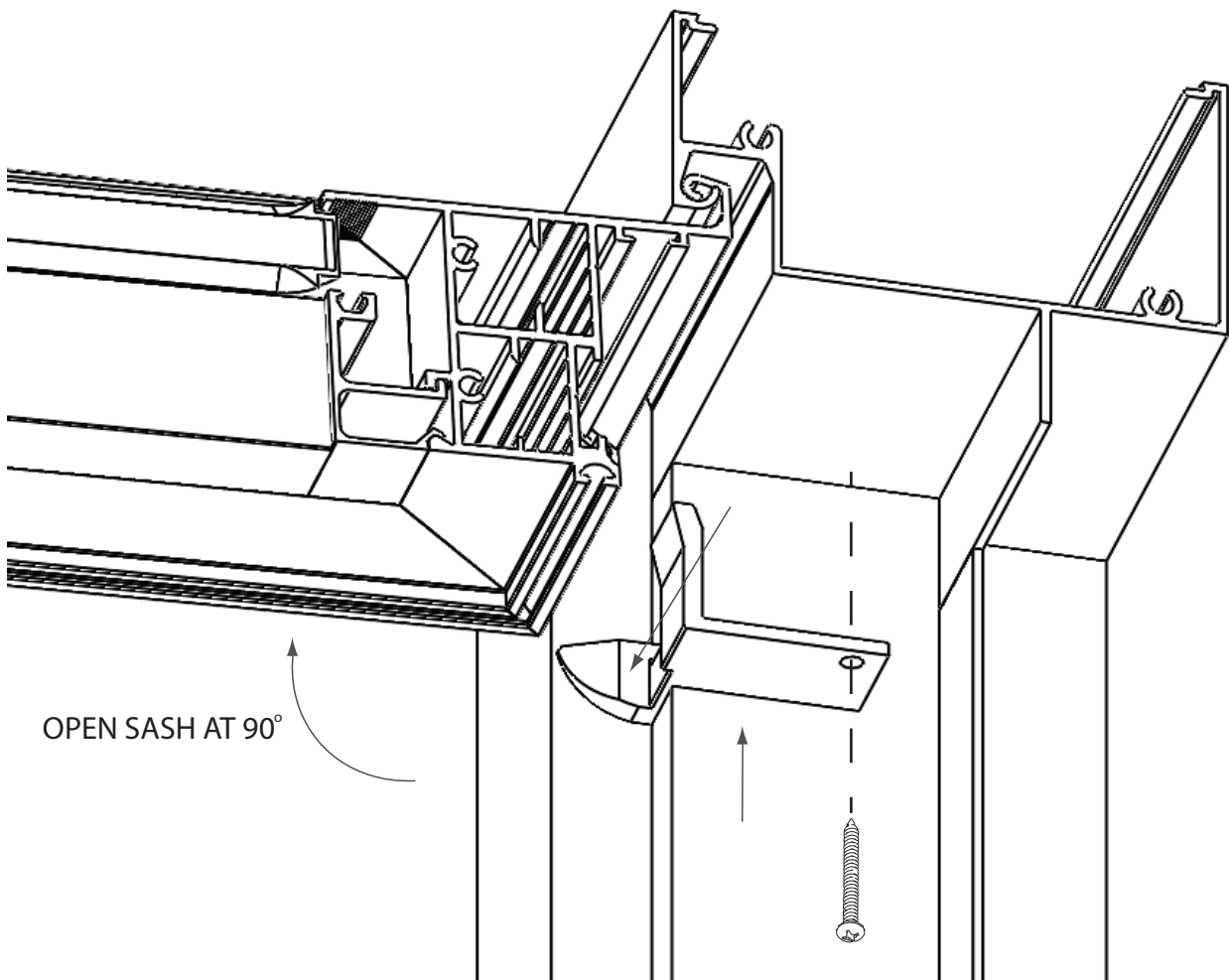

See also: Disclaimer and Copyright information on page 3

1859 Chainwinder Box End Cap

All raw joints need to be sealed with small joint sealer or foam tab option.

Fabrication

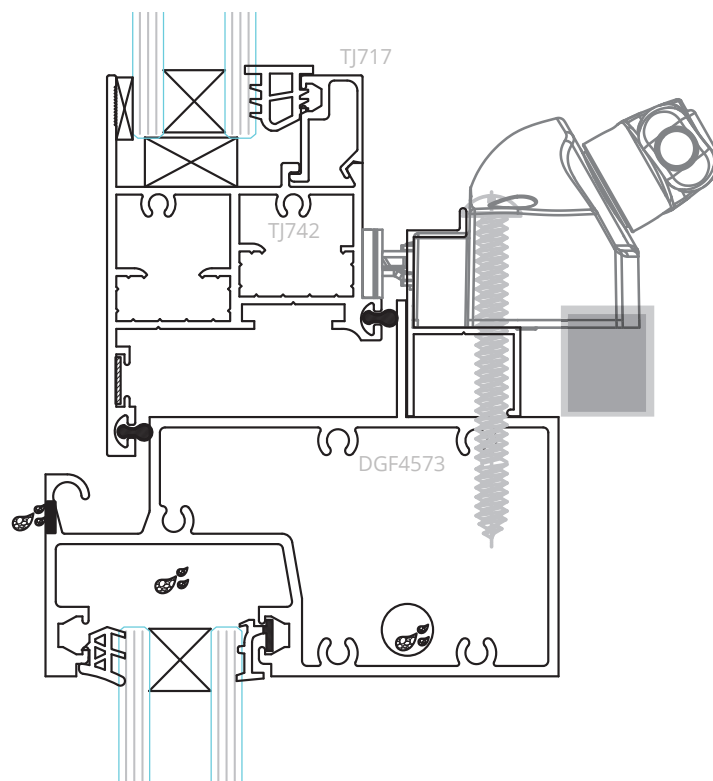
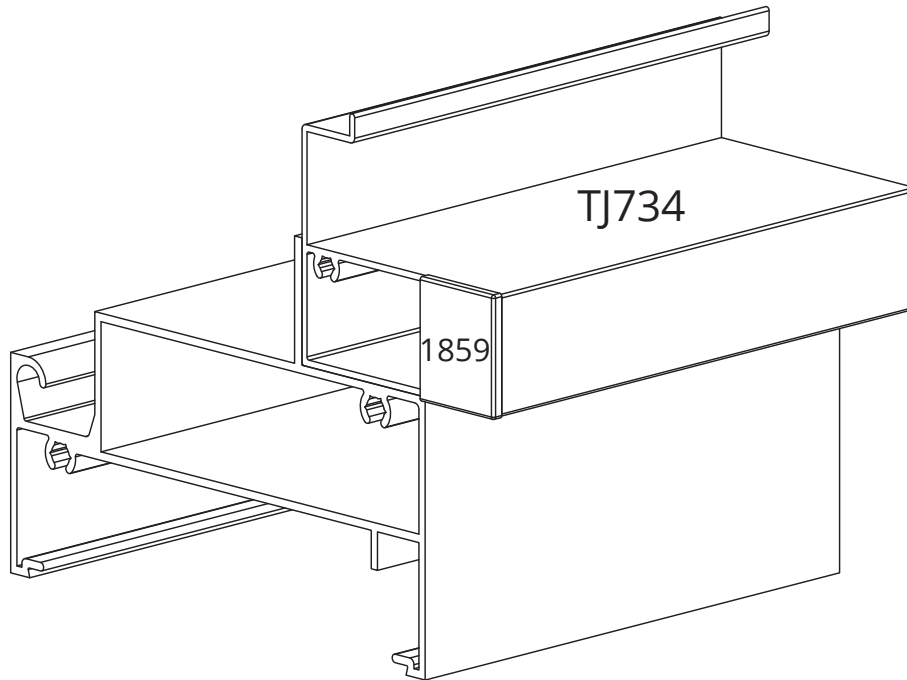

See also: Disclaimer and Copyright information on page 3

Electric Chainwinder Box

All raw joints need to be sealed with small joint sealer or foam tab option.

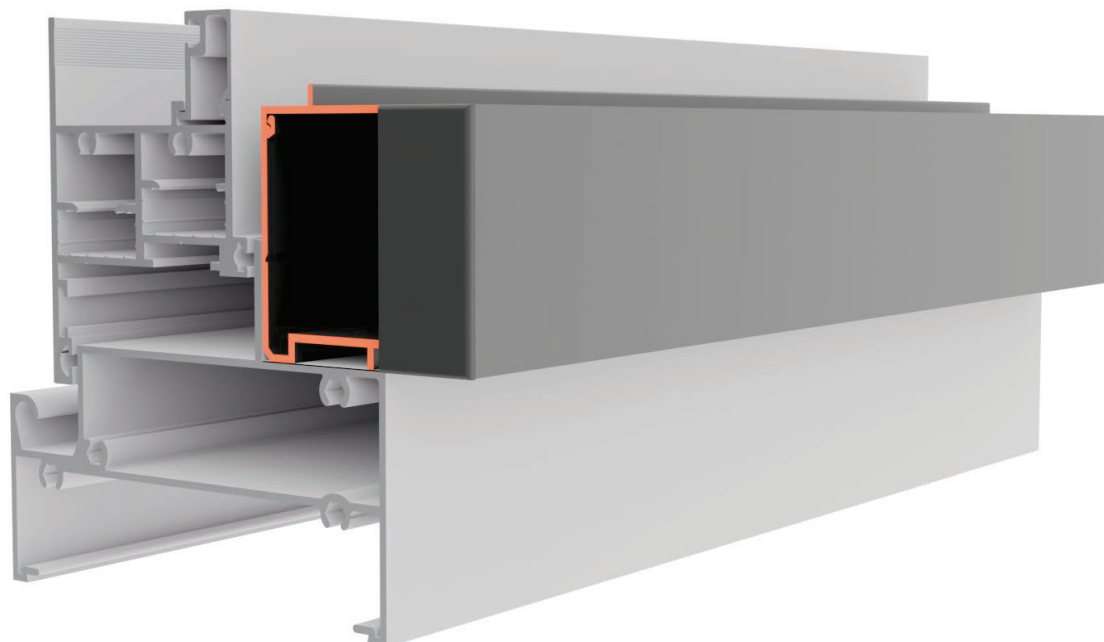

Fabrication

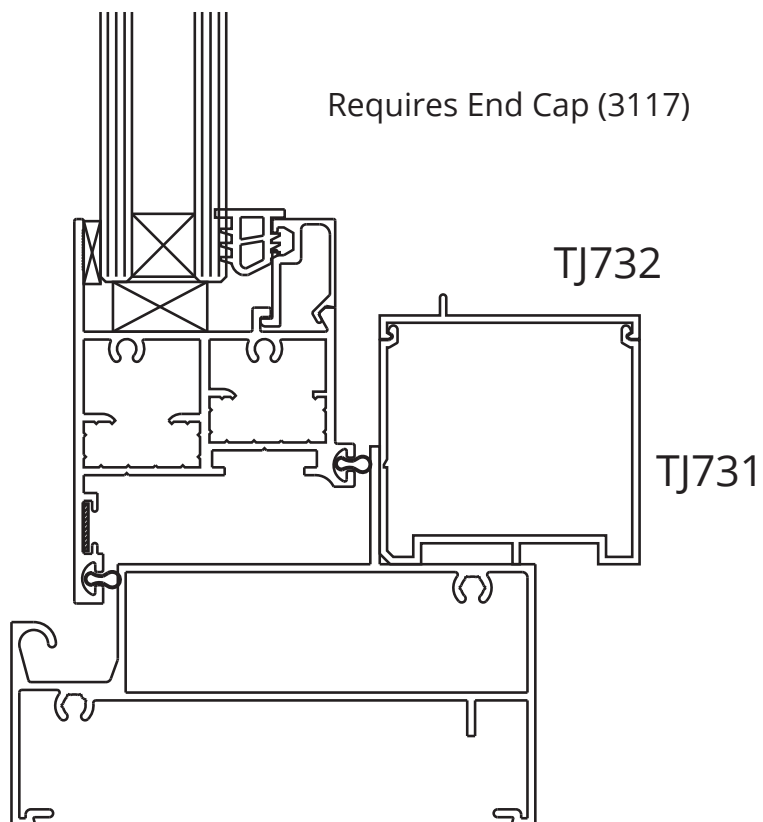

See also: Disclaimer and Copyright information on page 3

ROTO Locking Options

All raw joints need to be sealed with small joint sealer or foam tab option.

2 Point Locking

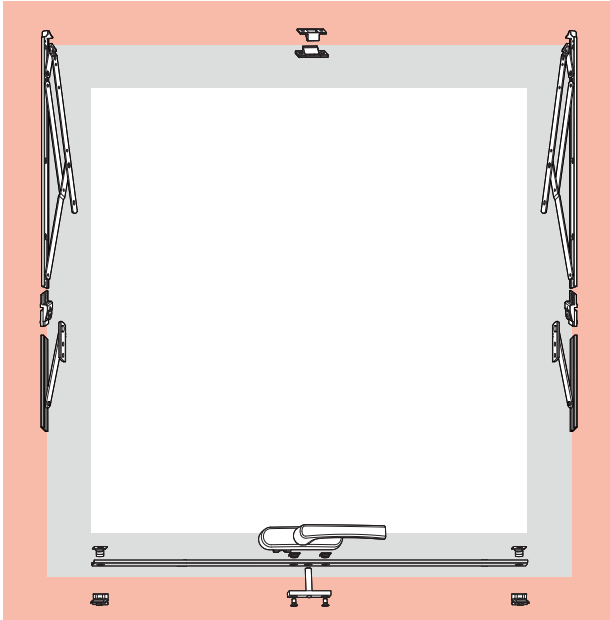

4 Point Locking

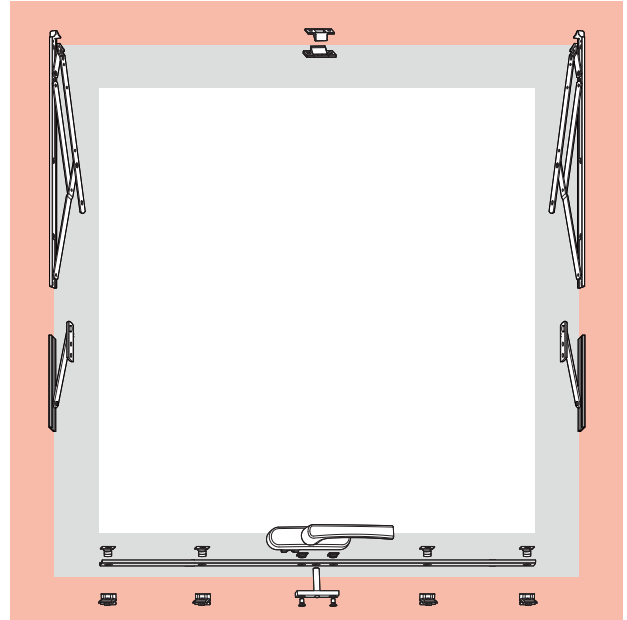

2+2 Point Locking

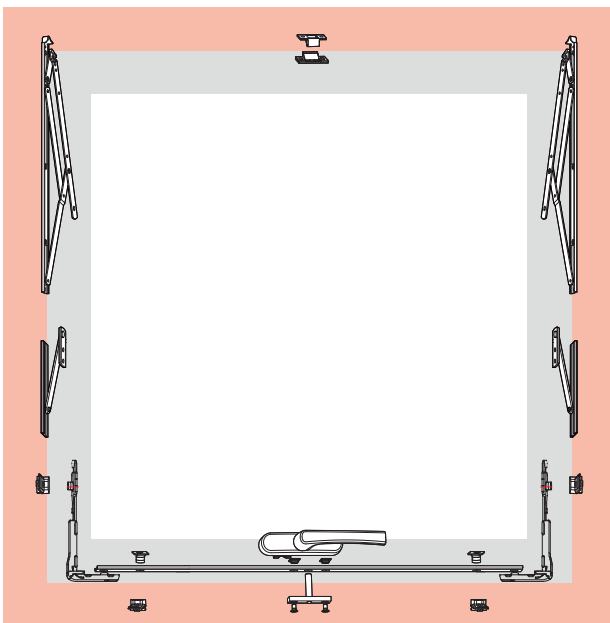

2+4 Point Locking

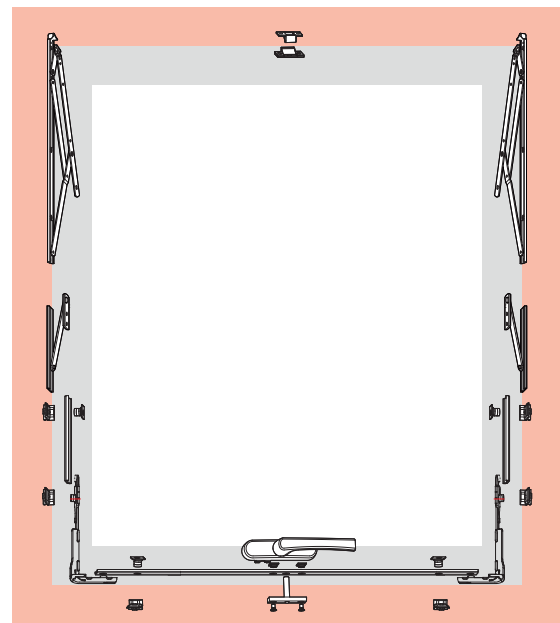

Note: 2+6 and 2+8 configurations also possible by adding more locking points up the sides

See also: Disclaimer and Copyright information on page 3

Hardware Accessories

All raw joints need to be sealed with small joint sealer or foam tab option.

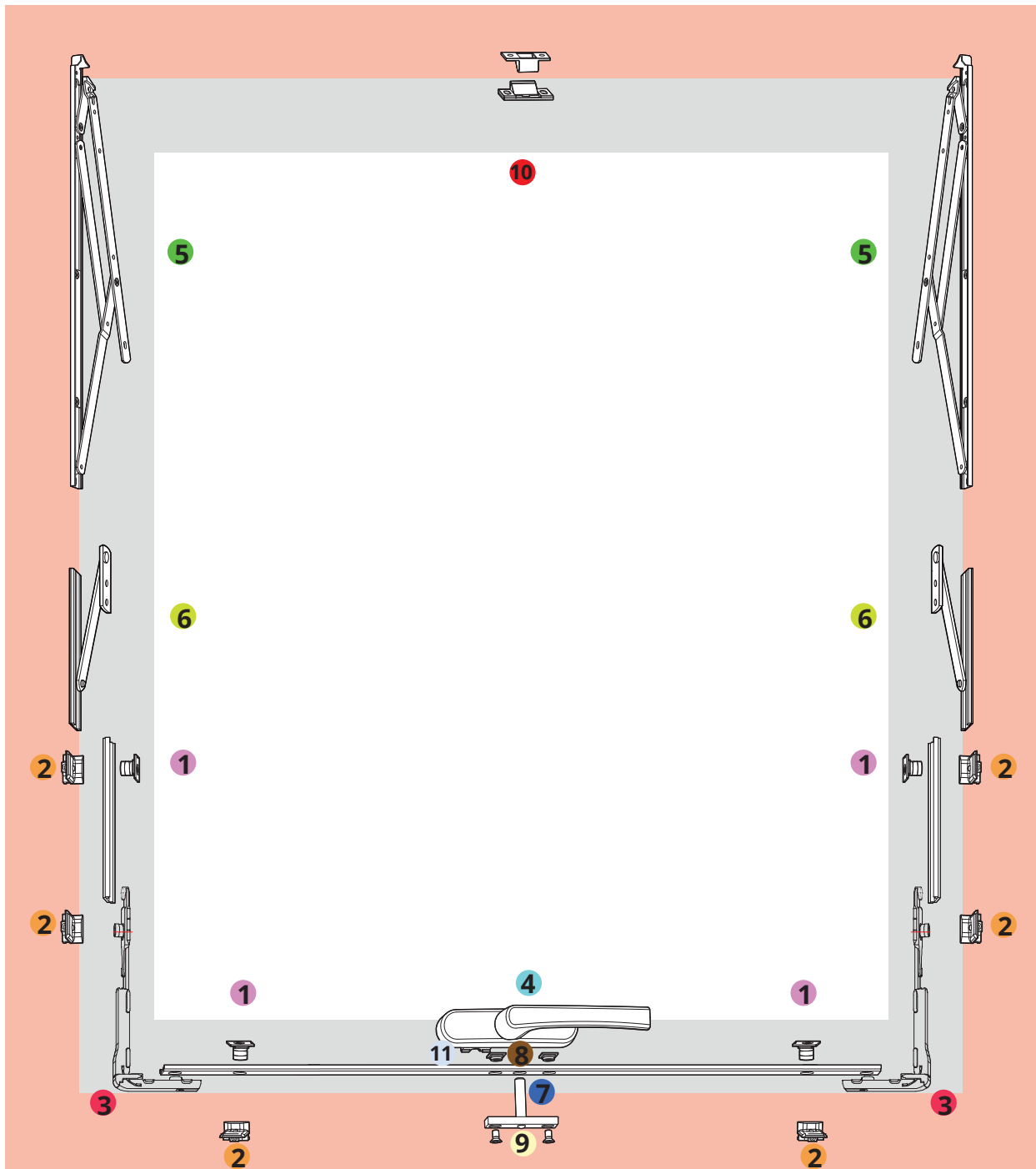

Fabrication

Note: See hardware section for list of hardware corresponding to the numbers on this chart.

See also: Disclaimer and Copyright information on page 3

Awning Hardware

All raw joints need to be sealed with small joint sealer or foam tab option.

Fabrication

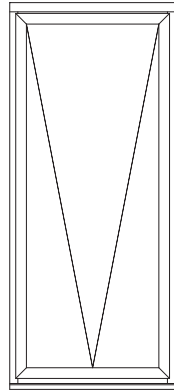

5004

- 1 Insertable Mushroom Cam 9.8mm (x2)



- 2 Strikers (x2)



5003

- 3 Corner Driver Kit (inc. 2 x Strikers)

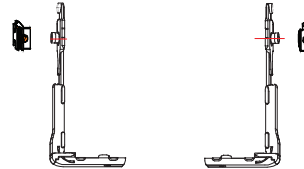

5011-SLV/WH/BLK

- 4 Geared Handle W/O Fork

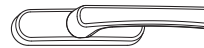

5005/6/7/8 Kit

- 5 S/S Friction Stays (1 set)

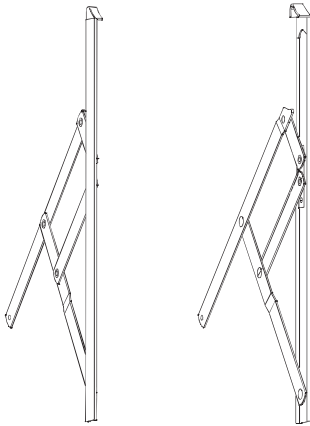

- 7 T Connector 30mm (x1)



- 2 Strikers (x2)



- 8 Security Connector for Handle (x2)



- 9 Countersunk Screw M5 x 8 (x2)



- 10 Centre Closers (Snubber) (x2)



- 6 Restrictor - 10" Outward Open 16mm (1 set)

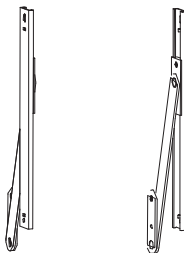

- 1 Insertable Mushroom Cam 9.8mm (x2)



- 11 Fork for Geared Handle (x1)

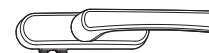

- 12 Adjustable Block (1 set) (5008 only)



See also: Disclaimer and Copyright information on page 3

Hardware Sizing Selection

All raw joints need to be sealed with small joint sealer or foam tab option.

Awning Stainless Steel Kits	
Darley Code	Description
5003	Open Out Kit - Corner Drives
	Includes corner drives (x2), Striker (x2)
5004	Open out Kit - Strike Kit
	Includes insertable mushroom cam (x2), Striker (x2)
5005	Open Out Kit - Top Hung
	For Sashes 501-700m High - 45kg
5006	Open Out Kit - Top Hung
	For Sashes 701-1200m High - 55kg
5007	Open Out Kit - Top Hung
	For Sashes 1201 - 1500mm High - 120kg
5008	Open Out Kit - Top Hung
	For Sashes 1501 - 2400mm High - 180kg

Handle / Cover	
Darley Code	Description
5011-SLV	Rotoline Geared Handle w/o Fork - SILVER
5011-WH	Rotoline Geared Handle w/o Fork - WHITE
5011-BLK	Rotoline Geared Handle w/o Fork - BLACK

See also: Disclaimer and Copyright information on page 3

Exploded Frame Assembly: Standard

All raw joints need to be sealed with small joint sealer or foam tab option.

Fabrication

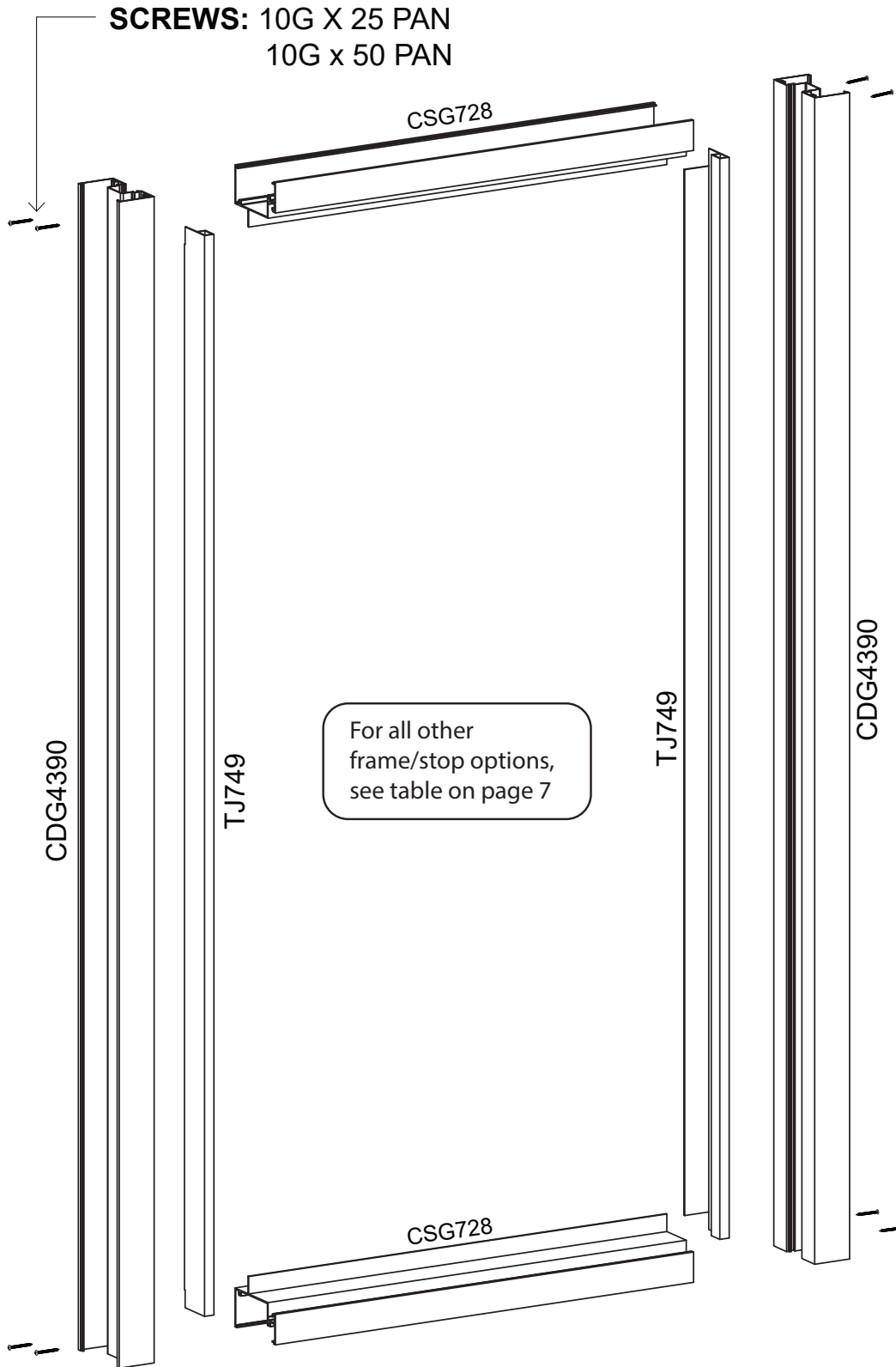

See also: Disclaimer and Copyright information on page 3

Exploded Frame Assembly: Recessed

All raw joints need to be sealed with small joint sealer or foam tab option.

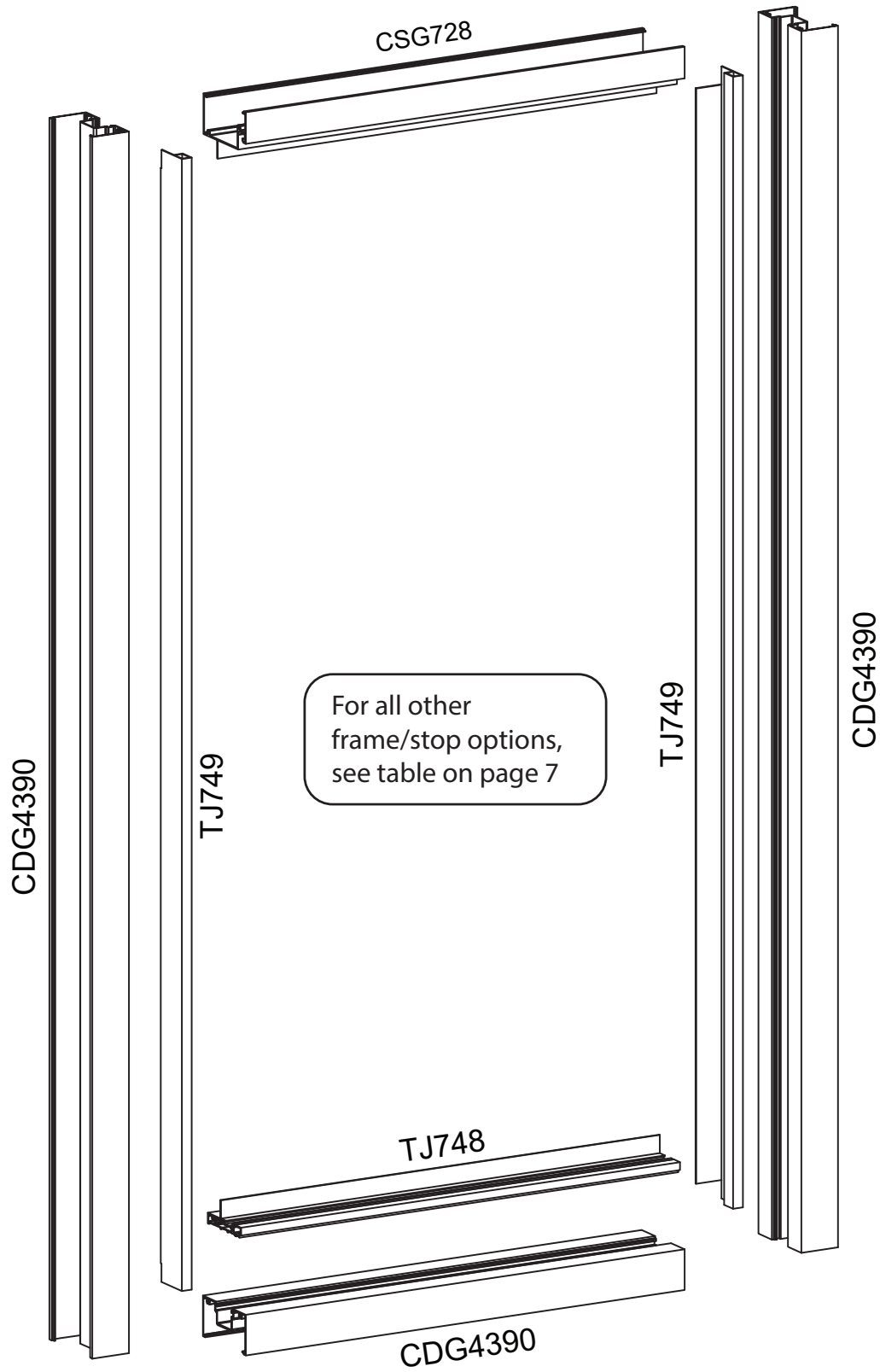

Fabrication

See also: Disclaimer and Copyright information on page 3

Sash Assembly: TJ742 (TJ747 For Hook Sash)

All raw joints need to be sealed with small joint sealer or foam tab option.

Fabrication

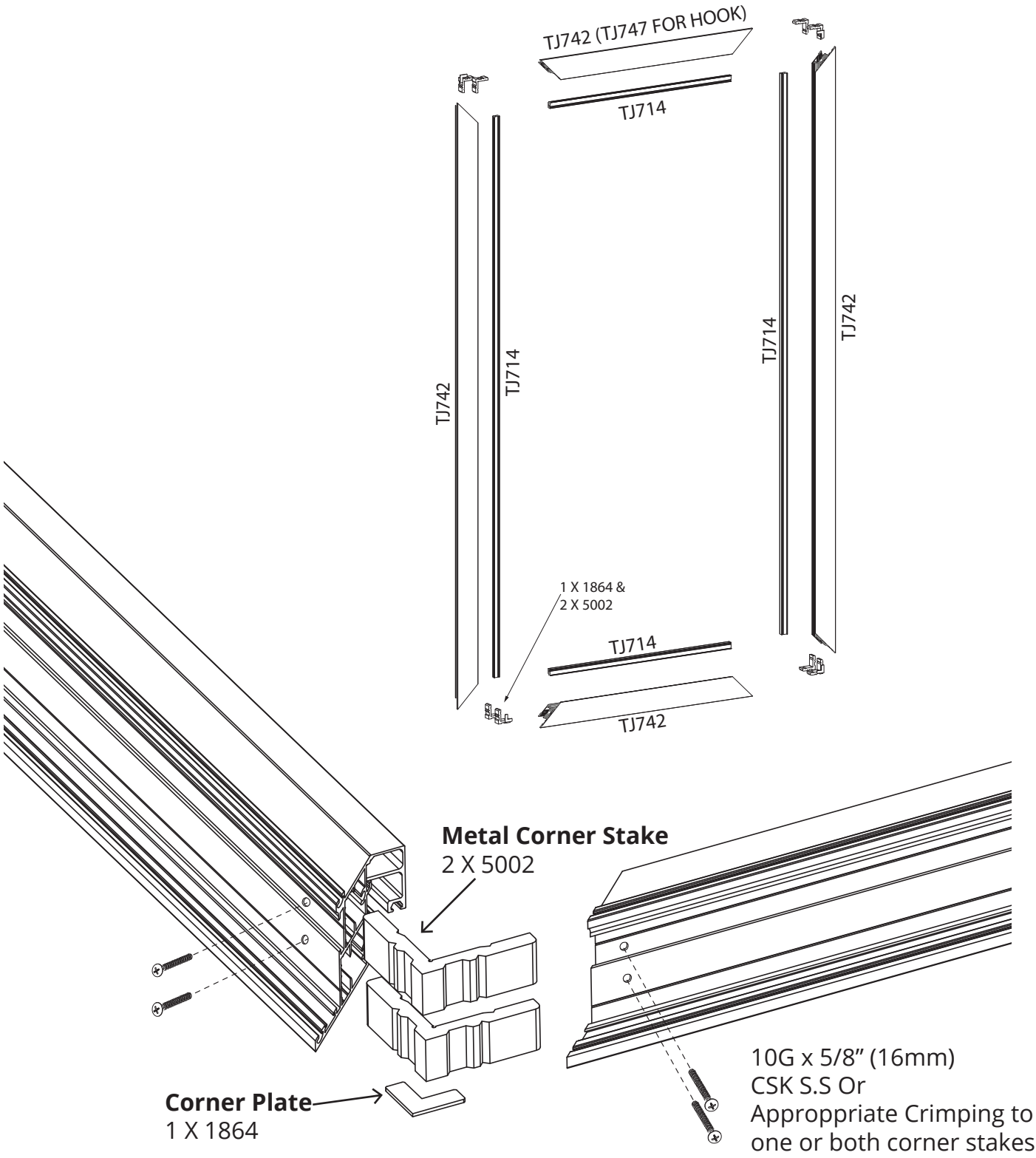

See also: Disclaimer and Copyright information on page 3

Cutting Formula: 100mm Centre Glazed Frame

All raw joints need to be sealed with small joint sealer or foam tab option.

Machining

The following diagram displays a general window configuration with formulae for calculating the cutting dimensions of frames to fit a given window opening.

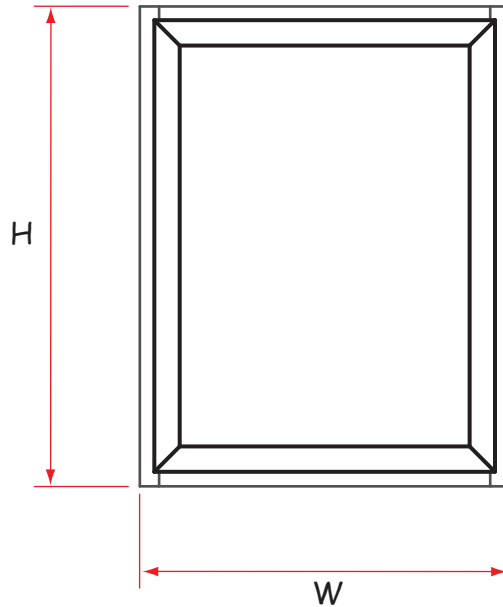

Fabrication

CODE	DESCRIPTION	QTY.	CUTTING FORMULA	NOTE
CSG301	JAMBS	2	H	TJ301 FOR 101.6MM CDG4301 FOR DOUBLE GLAZED Framing Options Pg.9
CSG728	HEAD / SILL	2	W - 100	Framing Options Pg.9
TJ749	JAMB STOP	2	W - 100	Machined. See Pg. 30
TJ747	AWNING SASH HOOK RAIL	1	W - 112	MITRE CUT
TJ742	AWNING SASH BOTTOM RAIL	1	W - 112	MITRE CUT
TJ742	AWNING SASH (VERTICAL)	2	H - 72	MITRE CUT
TJ716	SASH BEAD (HORIZONTAL)	2	W - 225	Glazing Options Pg. 44
TJ716	SASH BEAD (VERTICAL)	2	H - 218	Glazing Options Pg. 44
TJ734	CHAINWINDER BOX	1	W - 100	Machined See Pg 31

GLASS SIZES	QTY	Height	Width
	1	H-194	W-235

***Electric chainwinder box length is equal to sill length**

See also: Disclaimer and Copyright information on page 3

Cutting Formula: 100mm Front Glazed Frame

All raw joints need to be sealed with small joint sealer or foam tab option.

The following diagram displays a general window configuration with formulae for calculating the cutting dimensions of frames to fit a given window opening.

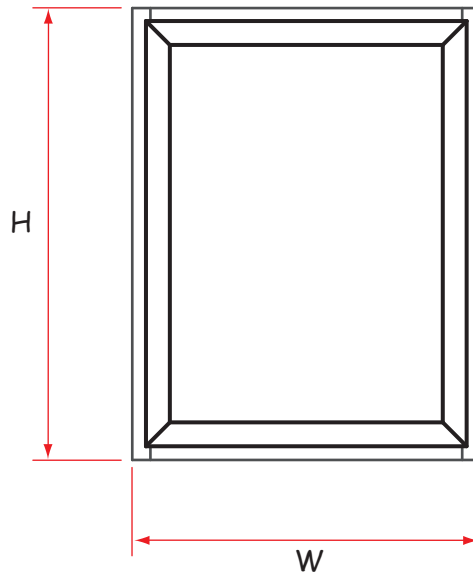

Fabrication

CODE	DESCRIPTION	QTY.	CUTTING FORMULA	NOTE
FGS401	JAMBS	2	H	DGF4501 FOR DOUBLE GLAZED
DGF4573	HEAD / SILL	2	W - 100	Framing Options Pg.9
TJ749	JAMB STOP	2	W - 100	Machined. See Pg. 30
TJ747	AWNING SASH HOOK RAIL	1	H - 112	MITRE CUT
TJ742	AWNING SASH BOTTOM RAIL	1	W - 112	MITRE CUT
TJ742	AWNING SASH (VERTICAL)	2	H - 72	MITRE CUT
TJ716/717	SASH BEAD (HORIZONTAL)	2	W - 225	Glazing Options Pg. 44
TJ716/717	SASH BEAD (VERTICAL)	2	H - 218	Glazing Options Pg. 44

GLASS SIZES	QTY	Height	Width
	1	H-194	W-235

***Electric chainwinder box length is equal to sill length**

See also: Disclaimer and Copyright information on page 3

Cutting Formula: 150mm Centre Glazed Frame

All raw joints need to be sealed with small joint sealer or foam tab option.

The following diagram displays a general window configuration with formulae for calculating the cutting dimensions of frames to fit a given window opening.

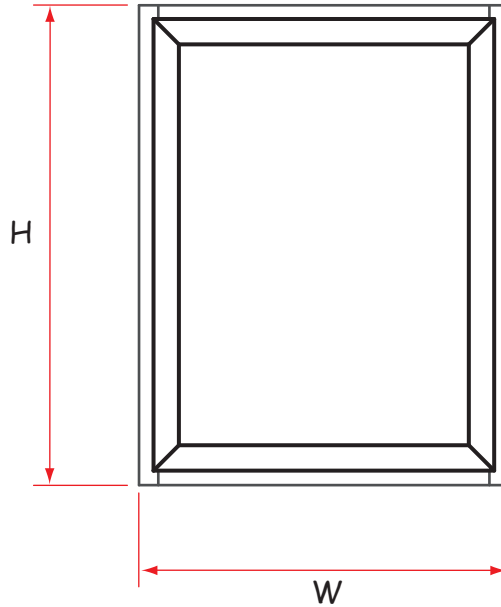

Fabrication

CODE	DESCRIPTION	QTY.	CUTTING FORMULA	NOTE
CDG6501	JAMBS	2	H	Framing Options Pg.9
CDG6728	HEAD / SILL	2	W - 100	Framing Options Pg.9
TJ749	JAMB STOP	2	W - 100	Machined. See Pg. 30
TJ747	AWNING SASH HOOK RAIL	1	H - 112	MITRE CUT
TJ742	AWNING SASH BOTTOM RAIL	1	W - 112	MITRE CUT
TJ742	AWNING SASH (VERTICAL)	2	H - 72	MITRE CUT
TJ717	SASH BEAD (HORIZONTAL)	2	W - 225	Glazing Options Pg. 44
TJ717	SASH BEAD (VERTICAL)	2	H - 218	Glazing Options Pg. 44
TJ734	CHAINWINDER BOX	1	W -100	Machined See Pg 31

GLASS SIZES	QTY	Height	Width
	1	H-194	W-235

***Electric chainwinder box length is equal to sill length**

See also: Disclaimer and Copyright information on page 3

Cutting Formula: 150mm Front Glazed Frame

All raw joints need to be sealed with small joint sealer or foam tab option.

The following diagram displays a general window configuration with formulae for calculating the cutting dimensions of frames to fit a given window opening.

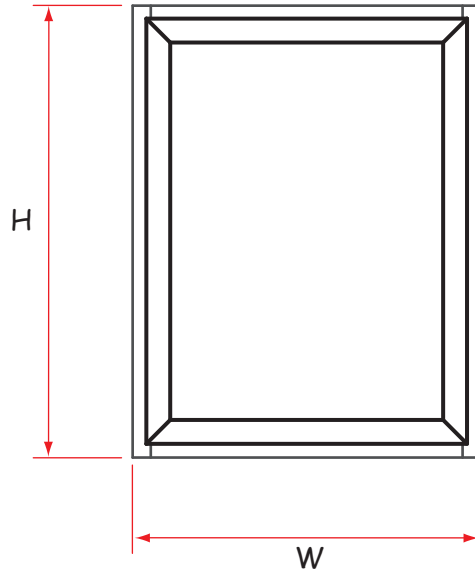

Fabrication

CODE	DESCRIPTION	QTY.	CUTTING FORMULA	NOTE
FGS601	JAMBS	2	H	DGF6561 FOR DOUBLE GLAZED
DGF6572	HEAD / SILL	2	W - 100	Framing Options Pg.9
TJ749	JAMB STOP	2	W - 100	Machined. See Pg. 30
TJ747	AWNING SASH HOOK RAIL	1	H - 100	MITRE CUT
TJ742	AWNING SASH BOTTOM RAIL	1	W - 112	MITRE CUT
TJ742	AWNING SASH (VERTICAL)	2	H - 72	MITRE CUT
TJ717	SASH BEAD (HORIZONTAL)	2	W - 225	Glazing Options Pg. 44
TJ717	SASH BEAD (VERTICAL)	2	H - 218	Glazing Options Pg. 44

GLASS SIZES	QTY	Height	Width
	1	H-194	W-235

***Electric chainwinder box length is equal to sill length**

See also: Disclaimer and Copyright information on page 3

Machining Detail For JambStop

All raw joints need to be sealed with small joint sealer or foam tab option.

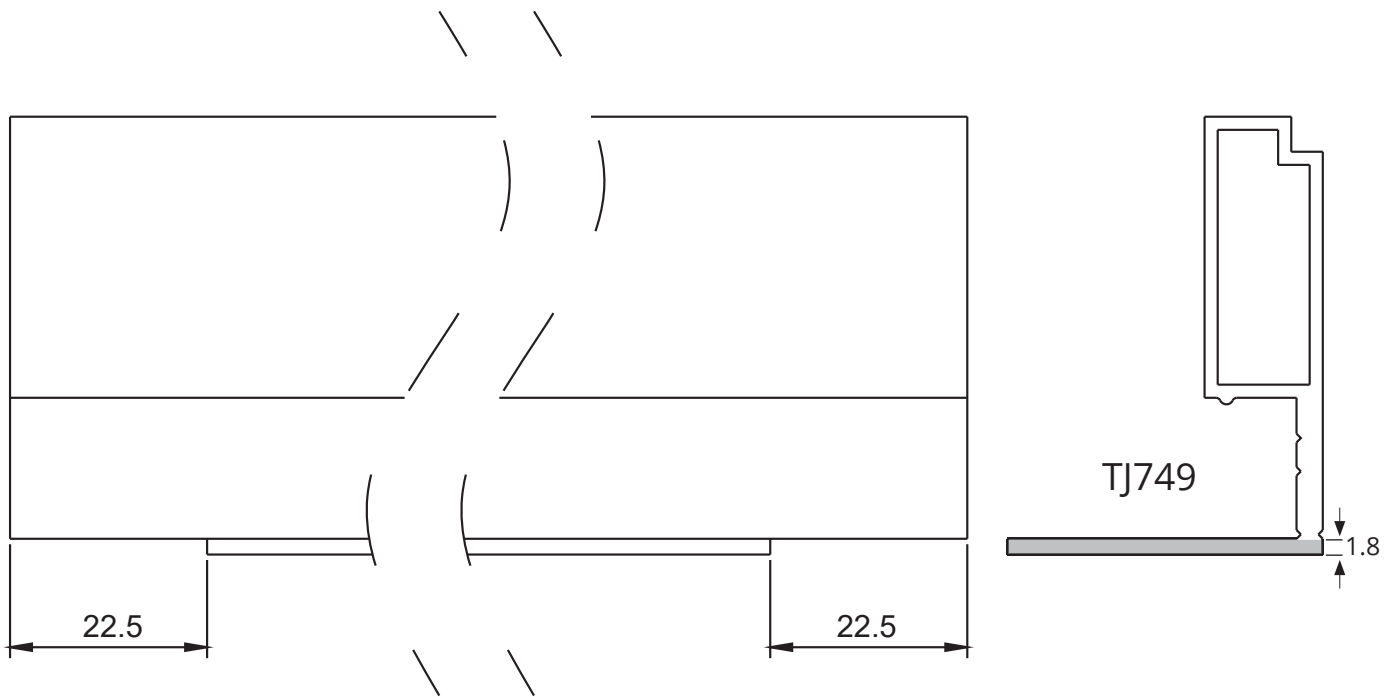
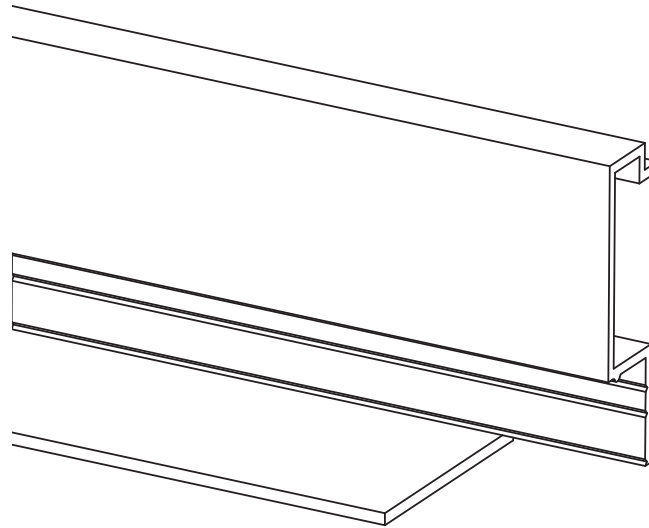

Fabrication

See also: Disclaimer and Copyright information on page 3

Machining Detail: Chainwinder for TJ737 & TJ734

All raw joints need to be sealed with small joint sealer or foam tab option.

Fabrication

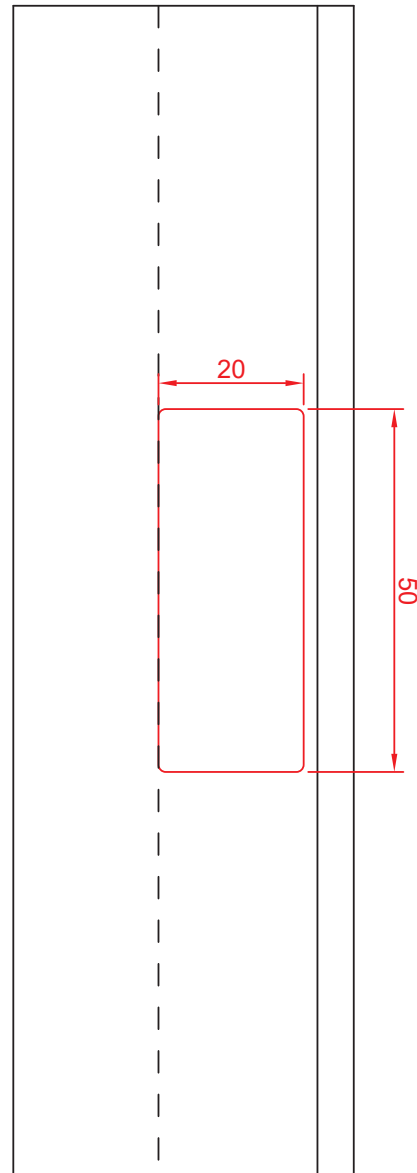
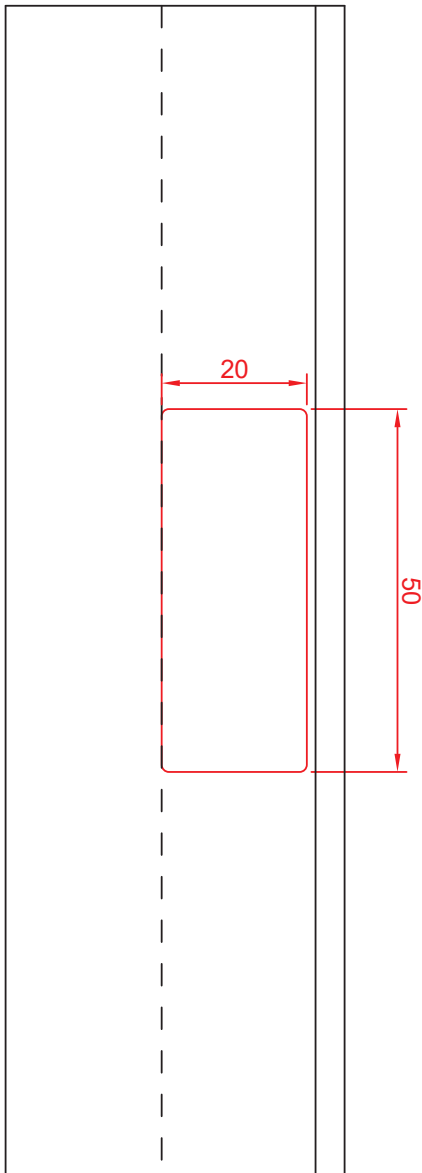
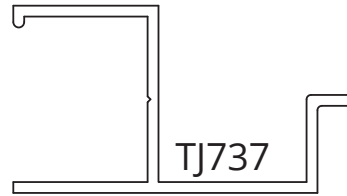
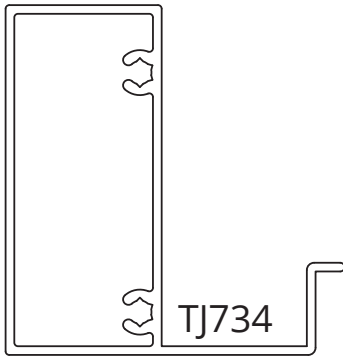

See also: Disclaimer and Copyright information on page 3

Flyscreen Retention

All raw joints need to be sealed with small joint sealer or foam tab option.

Flyscreen Clips (top of jamb)



Flyscreen Clip
Part No. 1892

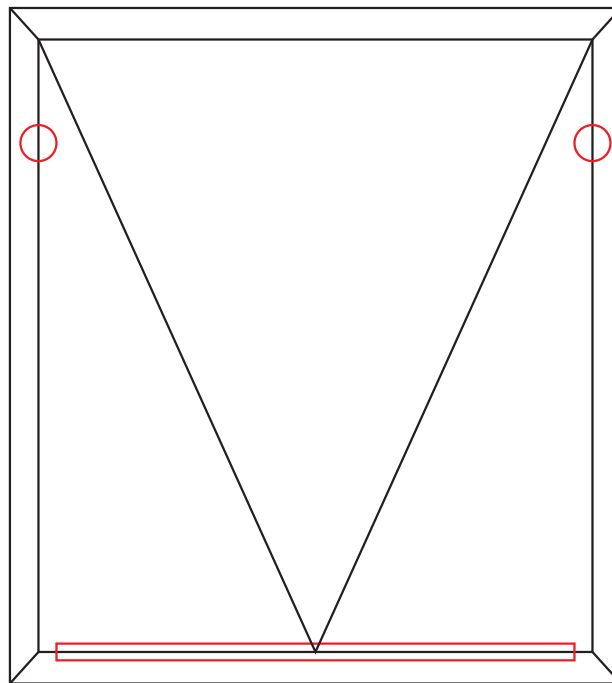
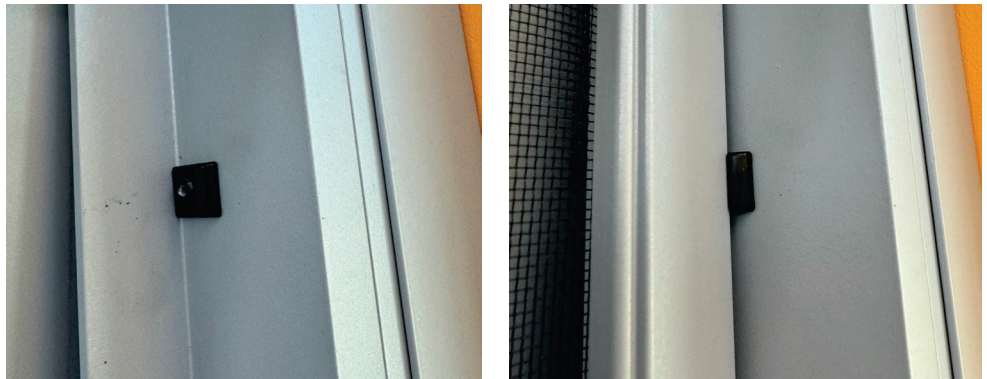

Fabrication

Retention leg on Chainwinder Box (bottom of screen)

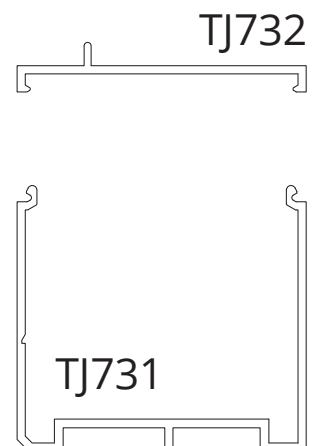
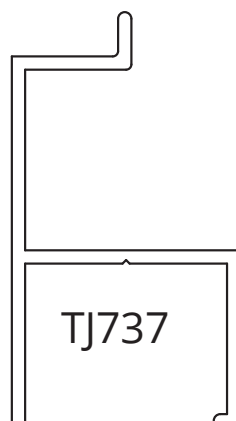
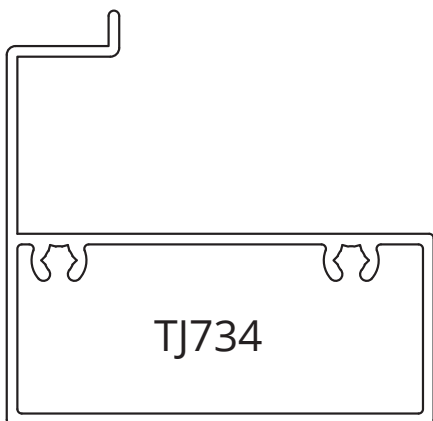

See also: Disclaimer and Copyright information on page 3

Sash Machining Detail For Multipoint

All raw joints need to be sealed with small joint sealer or foam tab option.

Route hole for handle fork and drill two holes for attachment

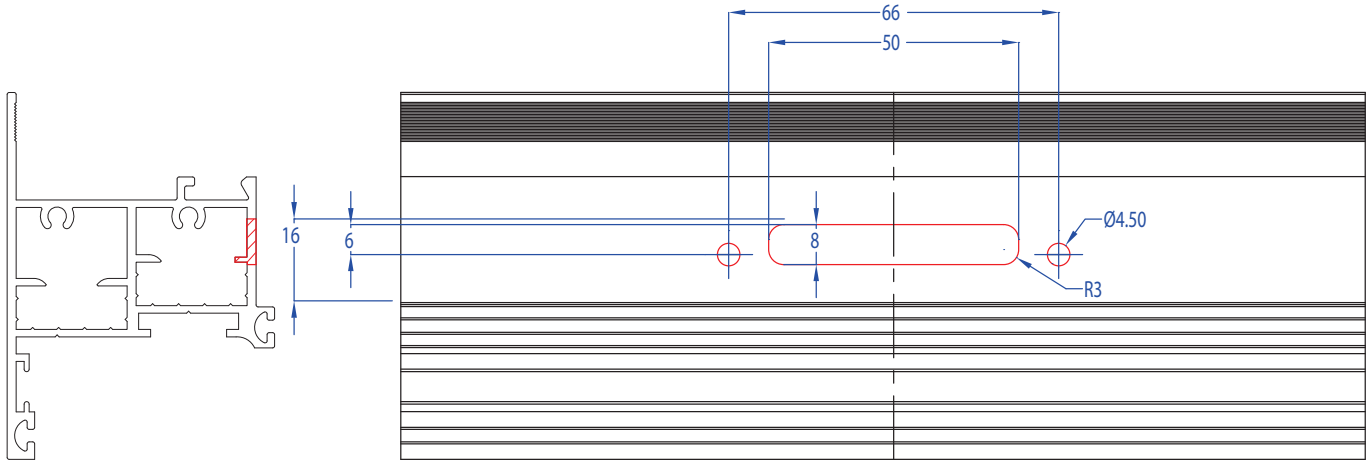

Route hole to insert T-connector

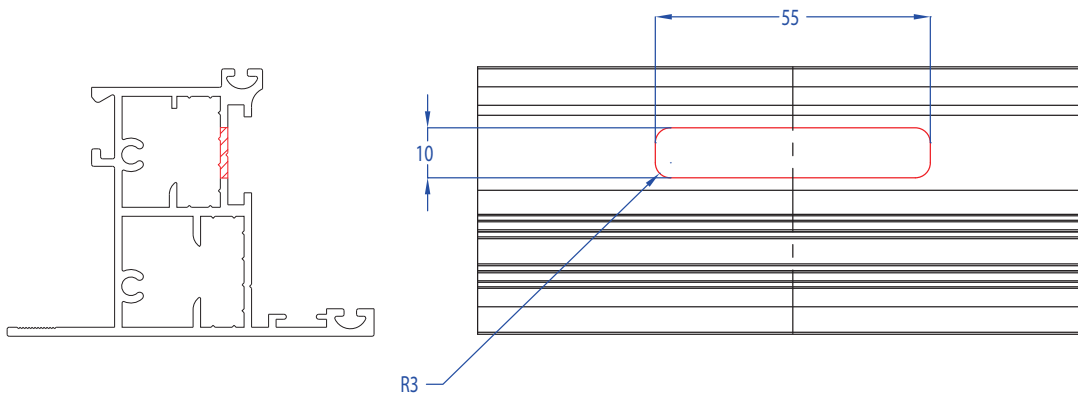

Corner fixings on mitre

Crop all four sash corners to accept the Control Bars and Corner Drives

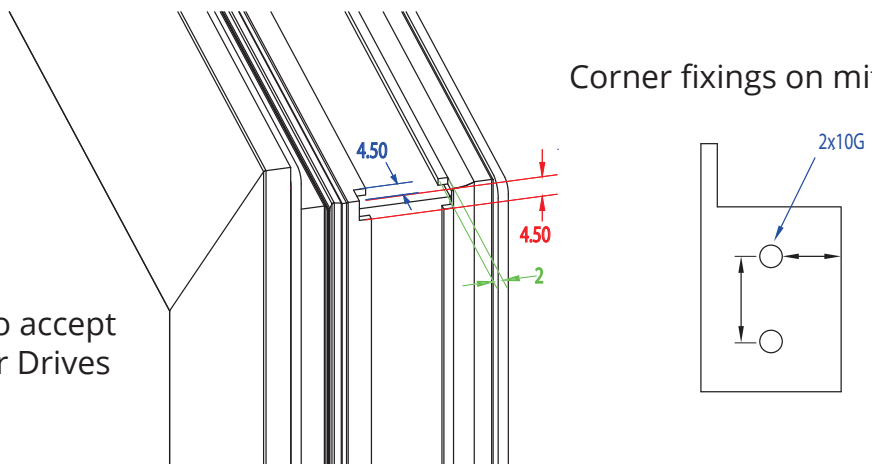

See also: Disclaimer and Copyright information on page 3

Crimp Details for 5002 Corner Stake

All raw joints need to be sealed with small joint sealer or foam tab option.

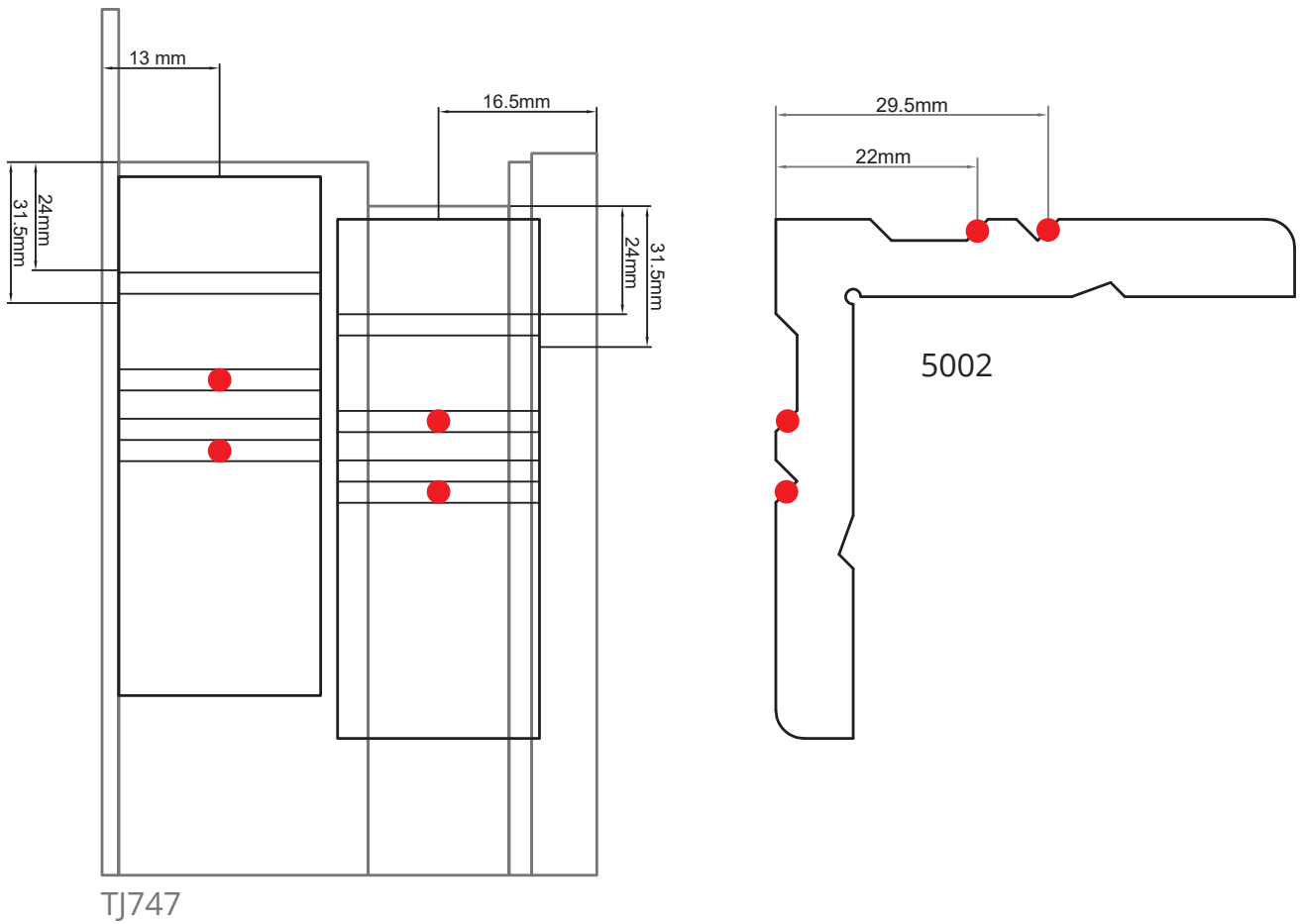

See also: Disclaimer and Copyright information on page 3

CGM001 and Handle Fork Machining Detail For Multipoint

All raw joints need to be sealed with small joint sealer or foam tab option.

Fabrication

* Crop all four sash corners to accept the Control Bars and Corner Drives

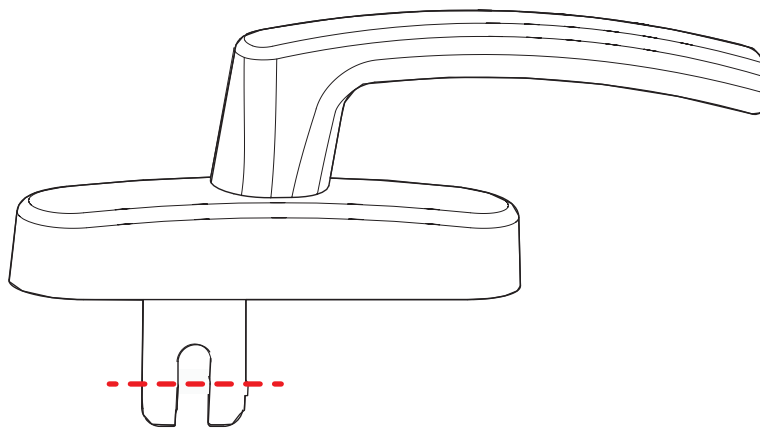
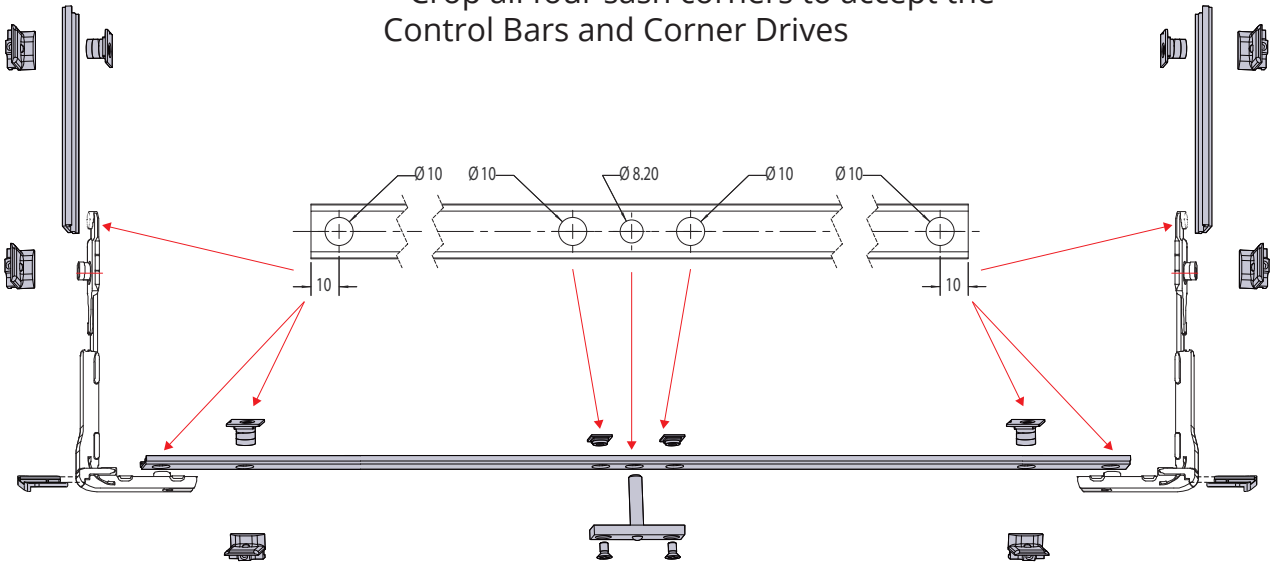

* Cut and file 5mm off the fork

See also: Disclaimer and Copyright information on page 3

Multipoint Order of Assembly: Non-Corner Drive

All raw joints need to be sealed with small joint sealer or foam tab option.

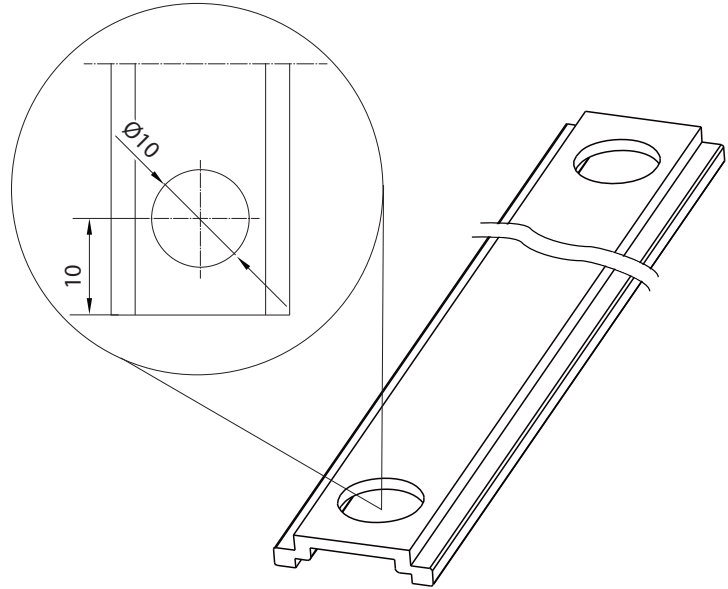

Fabrication

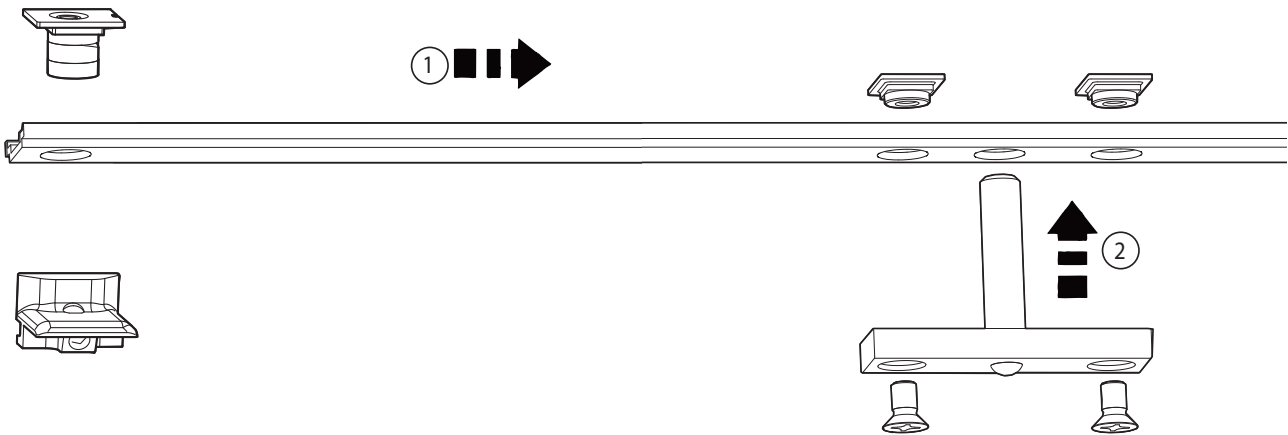

Once Handle has been face mounted (not including T Connector):

- Step 1: Slide the bottom Control Bar into sash groove with Mushroom Cams placed where necessary. Also ensure you place the Security Connector for the Handle.
TIP: Use some sticky tape to hold Security Connectors in place while sliding rod.
- Step 2: Screw in T Connector into bottom Control Bar centre holes.

See also: Disclaimer and Copyright information on page 3

Multipoint Order of Assembly: Corner Drive

All raw joints need to be sealed with small joint sealer or foam tab option.

Fabrication

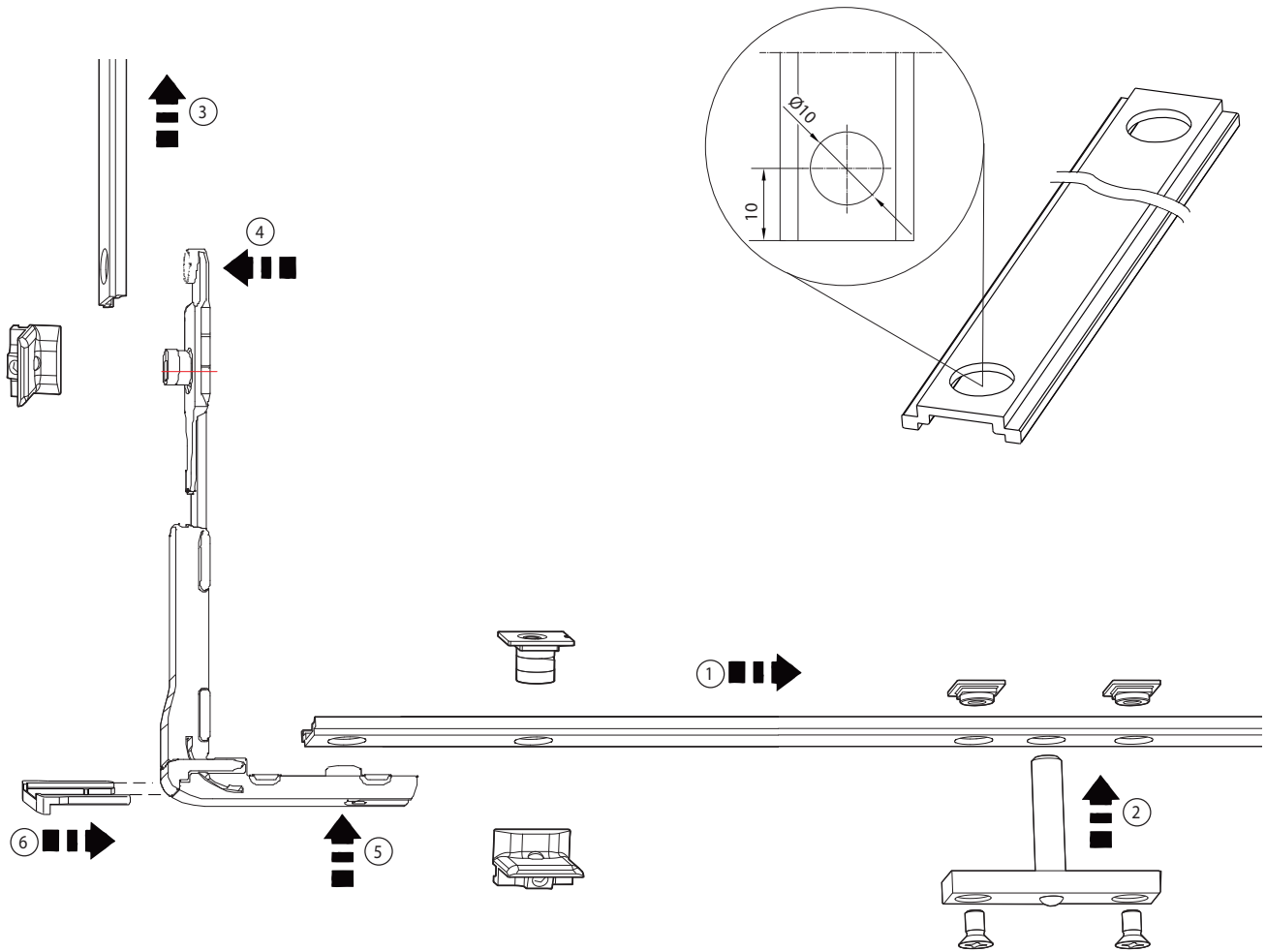

Once Handle has been face mounted (not including T Connector):

- Step 1: Slide the bottom Control Bar into sash groove with Mushroom Cams placed where necessary. Also ensure you place the Security Connectors for the Handle.
TIP: Use some sticky tape to hold Security Connectors in place while sliding rod.
- Step 2: Screw in T Connector into bottom Control Bar centre holes.
- Step 3: If using two side Control Bars for multiple side locking places, slide these into the sash grooves with Mushroom Cams placed where necessary.
- Step 4: Just before pushing in the side Control Bars completely, attach the Corner Drives to the side Control Bars.
- Step 5: Finish pushing side Control Bars up, pushing the bottom locating pin of the Corner Drives into the bottom Control Bar.
- Step 6: Push in each Corner Drive clip to secure the corners.

See also: Disclaimer and Copyright information on page 3

Striker Placement

All raw joints need to be sealed with small joint sealer or foam tab option.

Unlocked



Locked

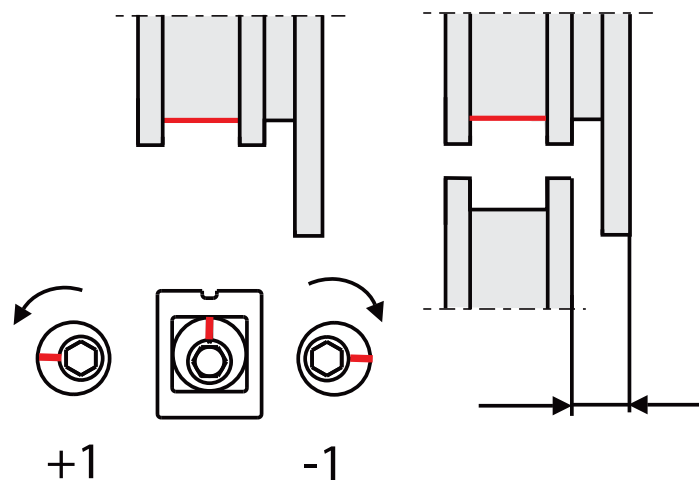

See also: Disclaimer and Copyright information on page 3

100mm Subhead Options

All raw joints need to be sealed with small joint sealer or foam tab option.

Fabrication

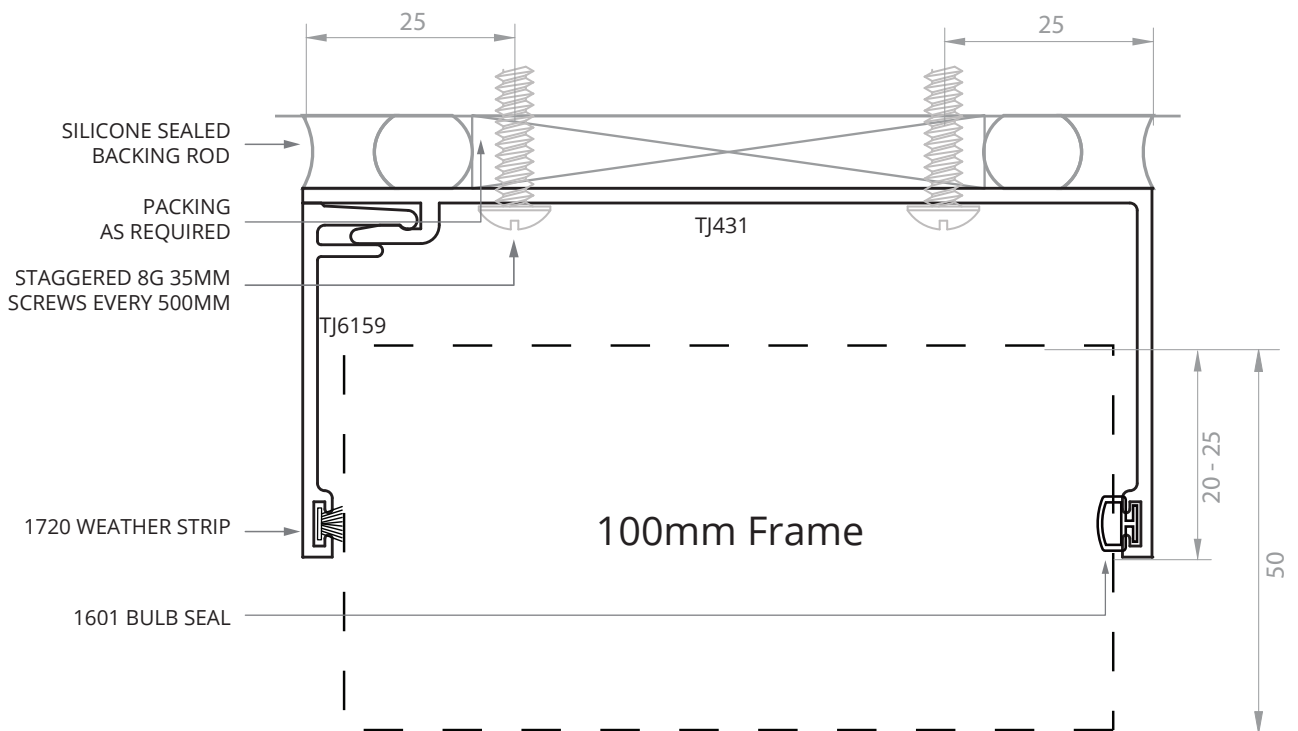
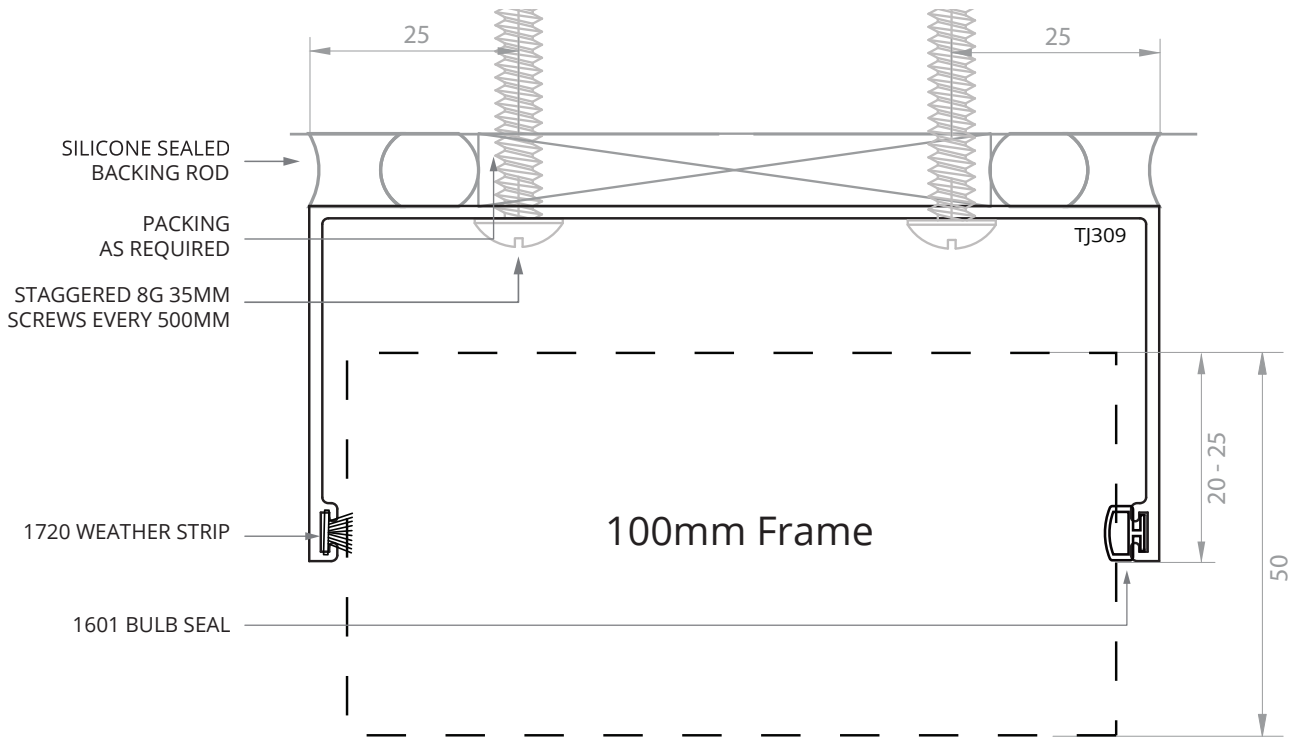

See also: Disclaimer and Copyright information on page 3

50MM HOOK AWNING

100mm SubJamb Options

All raw joints need to be sealed with small joint sealer or foam tab option.

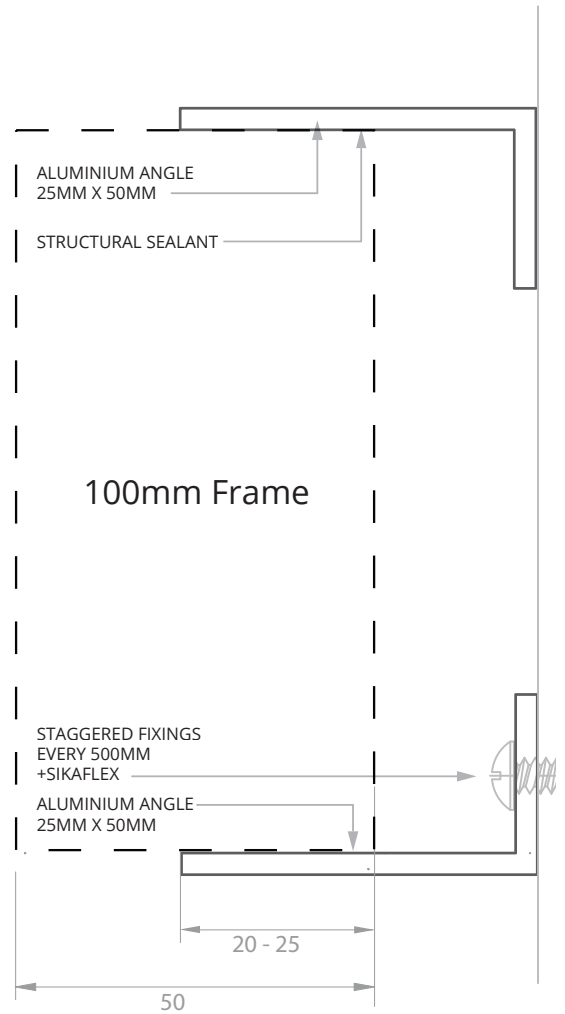
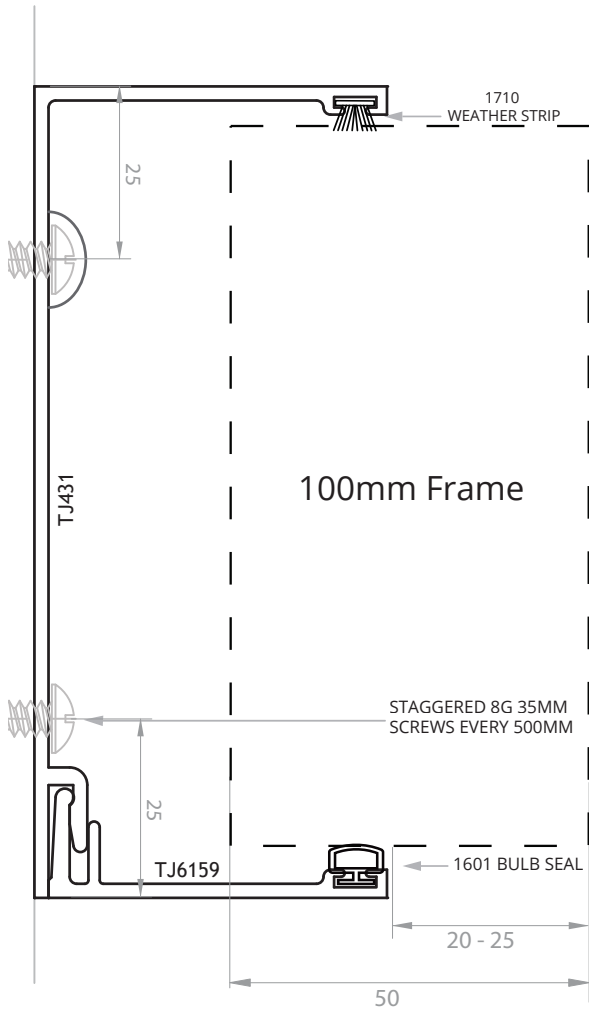

Fabrication

See also: Disclaimer and Copyright information on page 3

100mm Subframe Internal Bead

All raw joints need to be sealed with small joint sealer or foam tab option.

Fabrication

SQUARE CUT (INTERNAL BEAD)

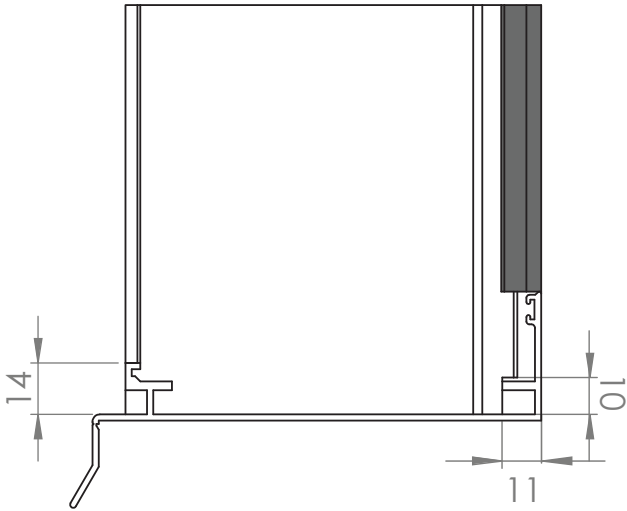

MACHINED (INTERNAL BEAD)

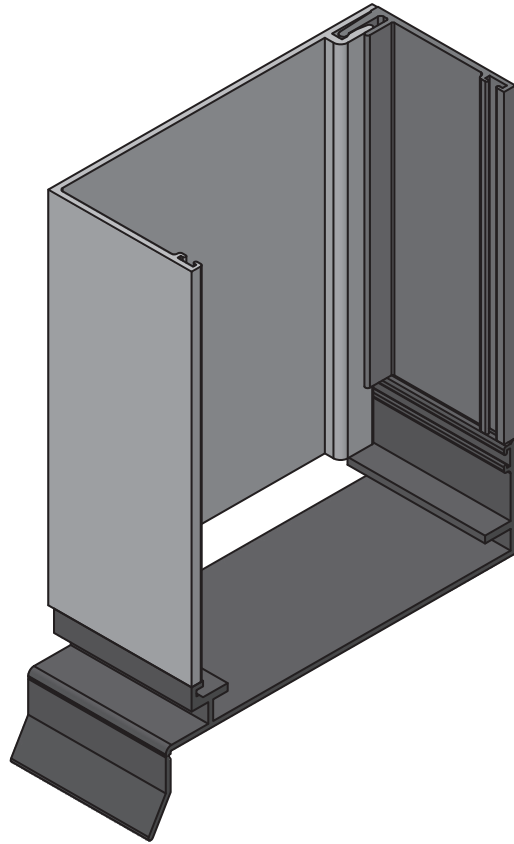
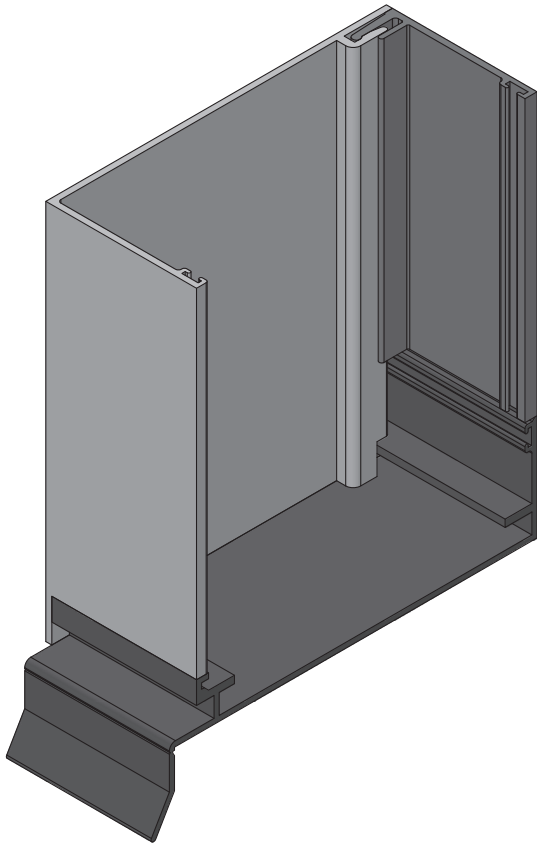
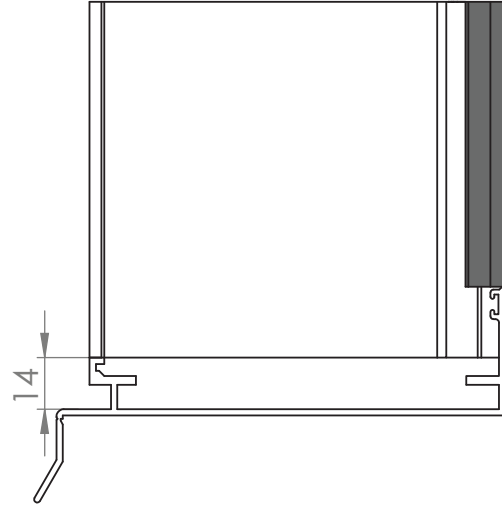

See also: Disclaimer and Copyright information on page 3

100mm Subframe External Bead

All raw joints need to be sealed with small joint sealer or foam tab option.

SQUARE CUT (EXTERNAL BEAD)

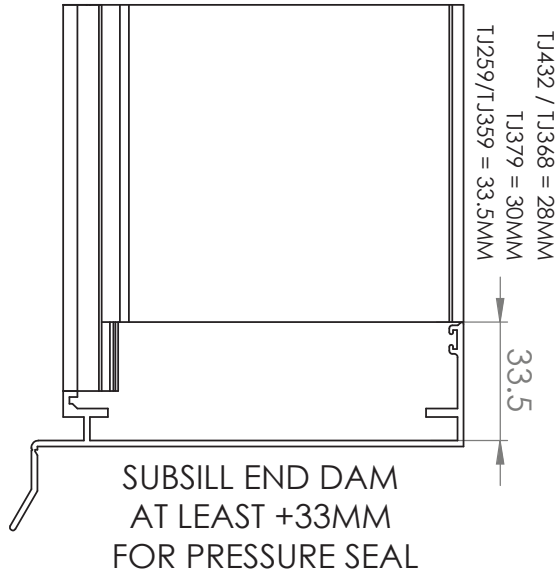

MACHINED (EXTERNAL BEAD)

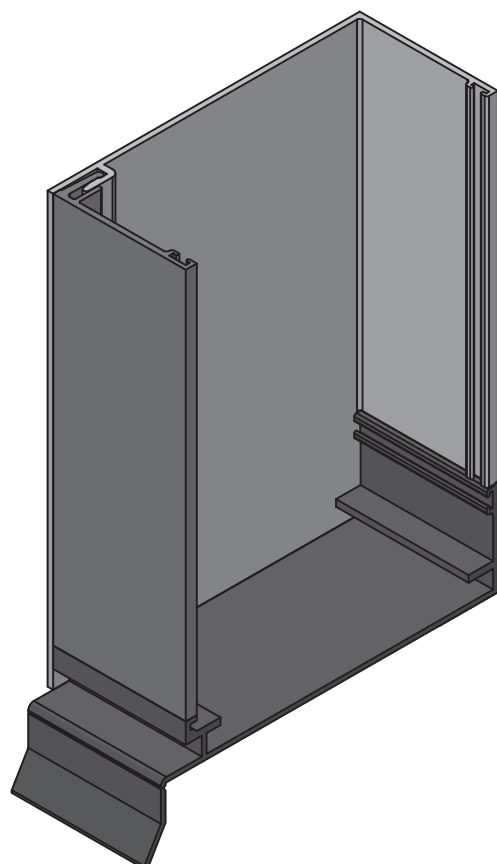
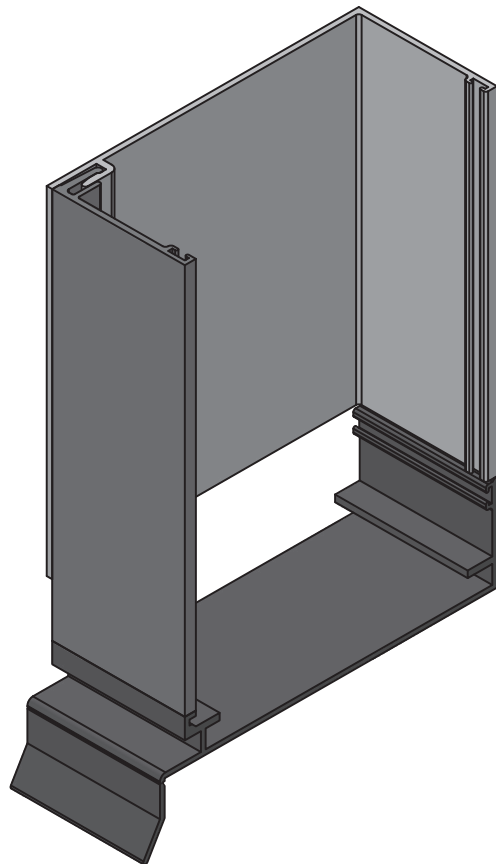
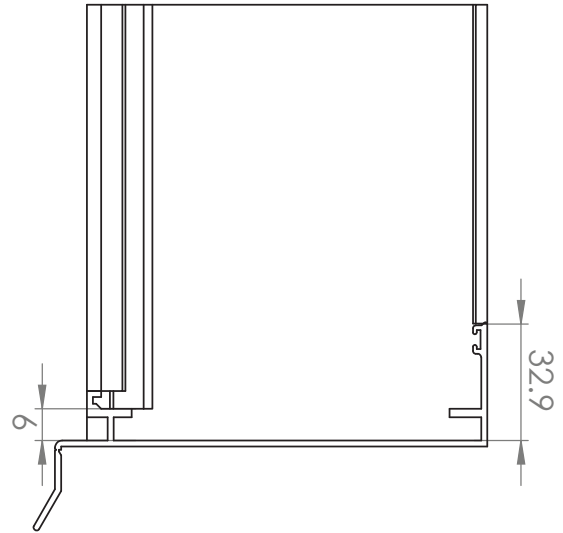

Fabrication

See also: Disclaimer and Copyright information on page 3

Subsill End-Dam Installation

All raw joints need to be sealed with small joint sealer or foam tab option.

Fabrication

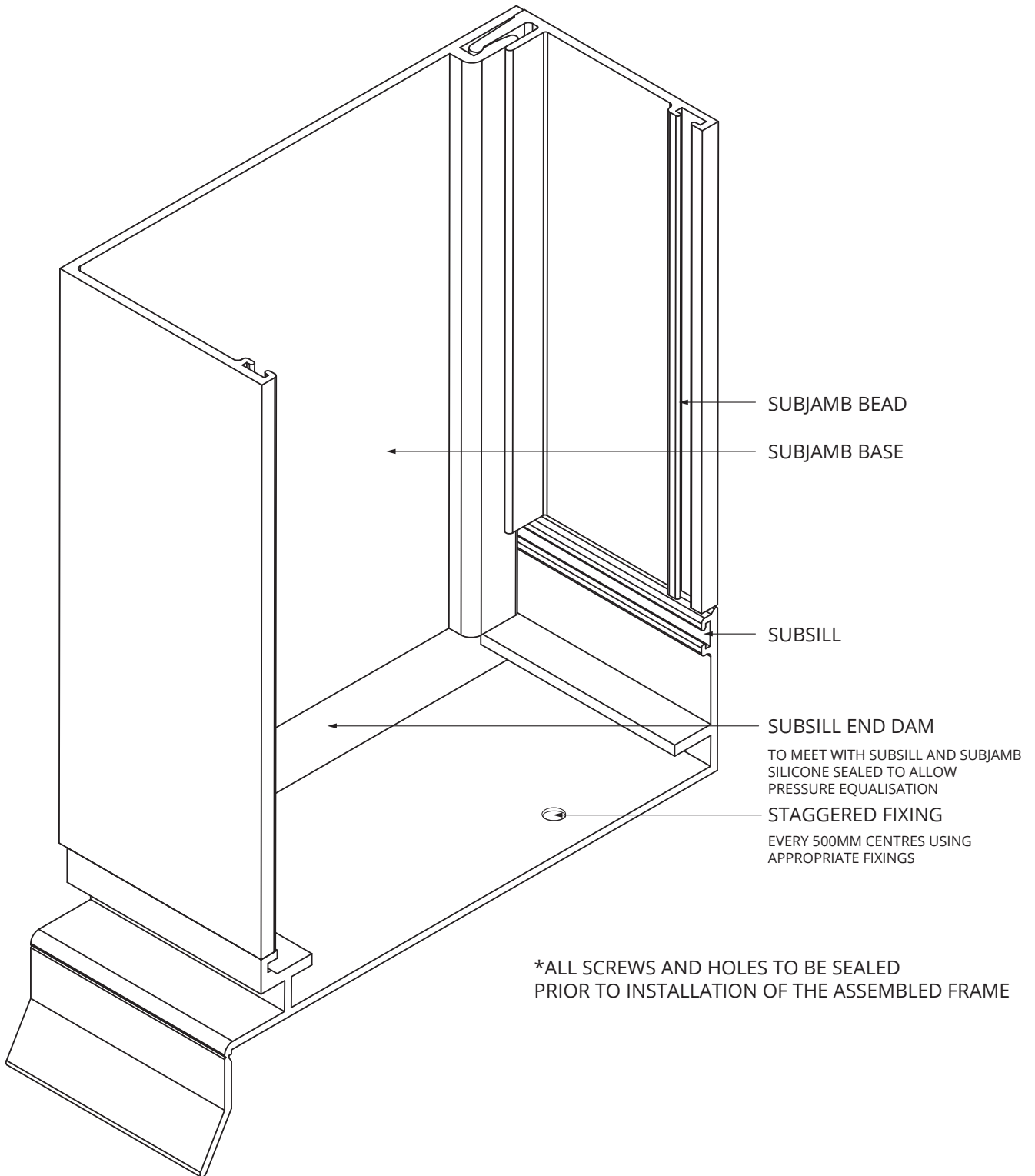

See also: Disclaimer and Copyright information on page 3

All raw joints need to be sealed with small joint sealer or foam tab option.

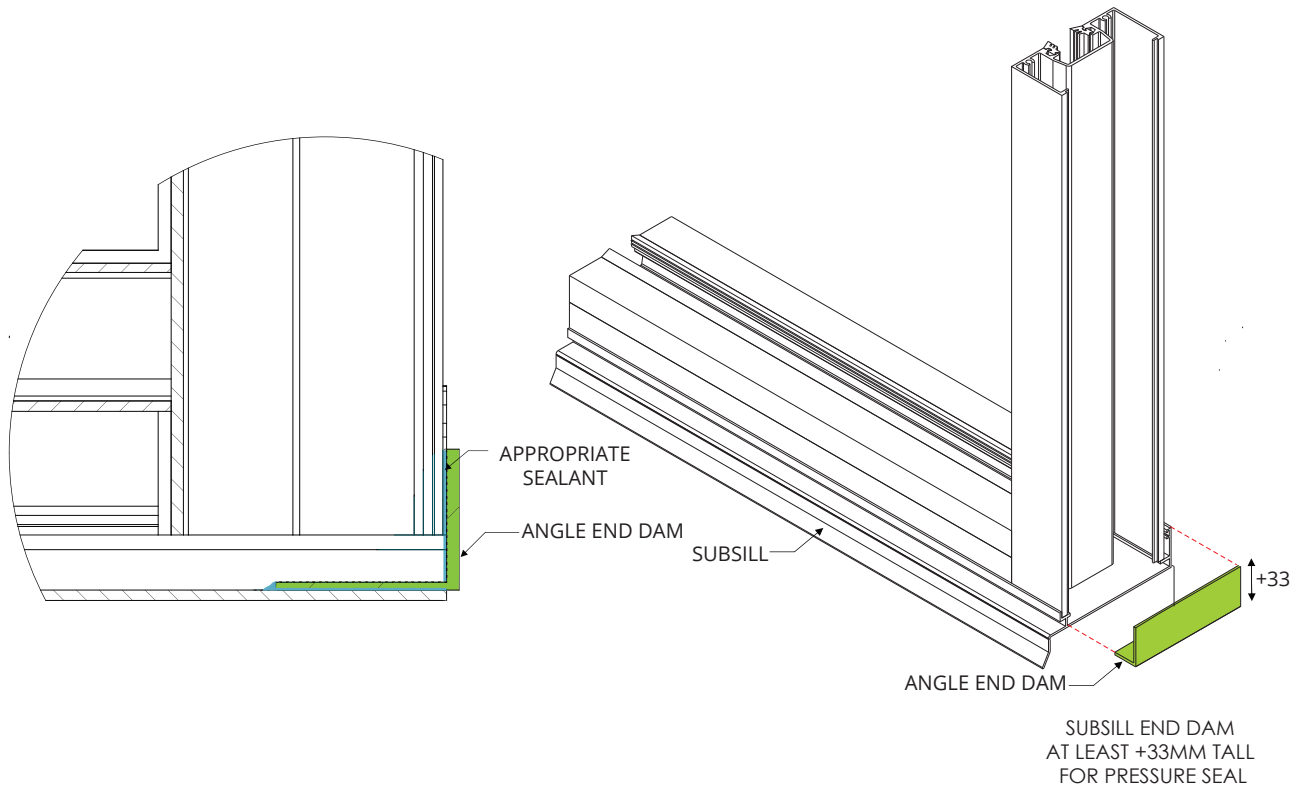
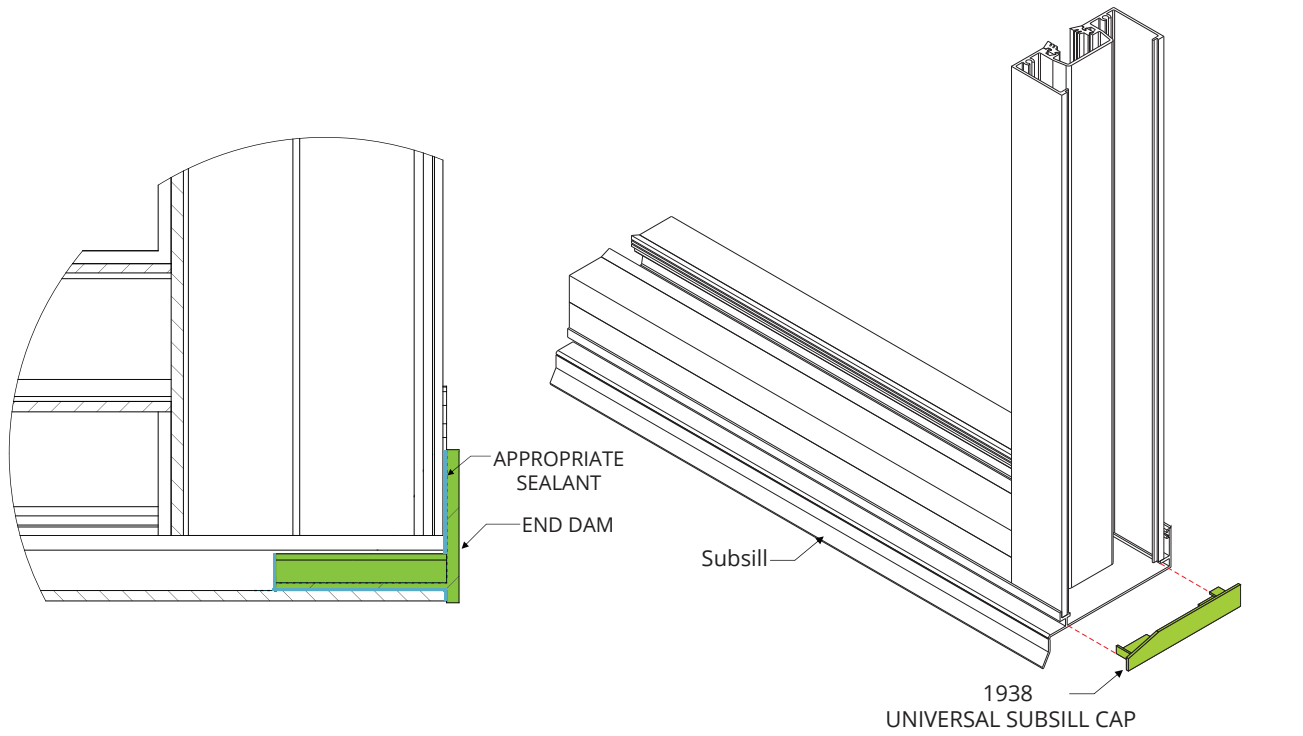

Fabrication

See also: Disclaimer and Copyright information on page 3

100mm Sump Sill

All raw joints need to be sealed with small joint sealer or foam tab option.

Fabrication

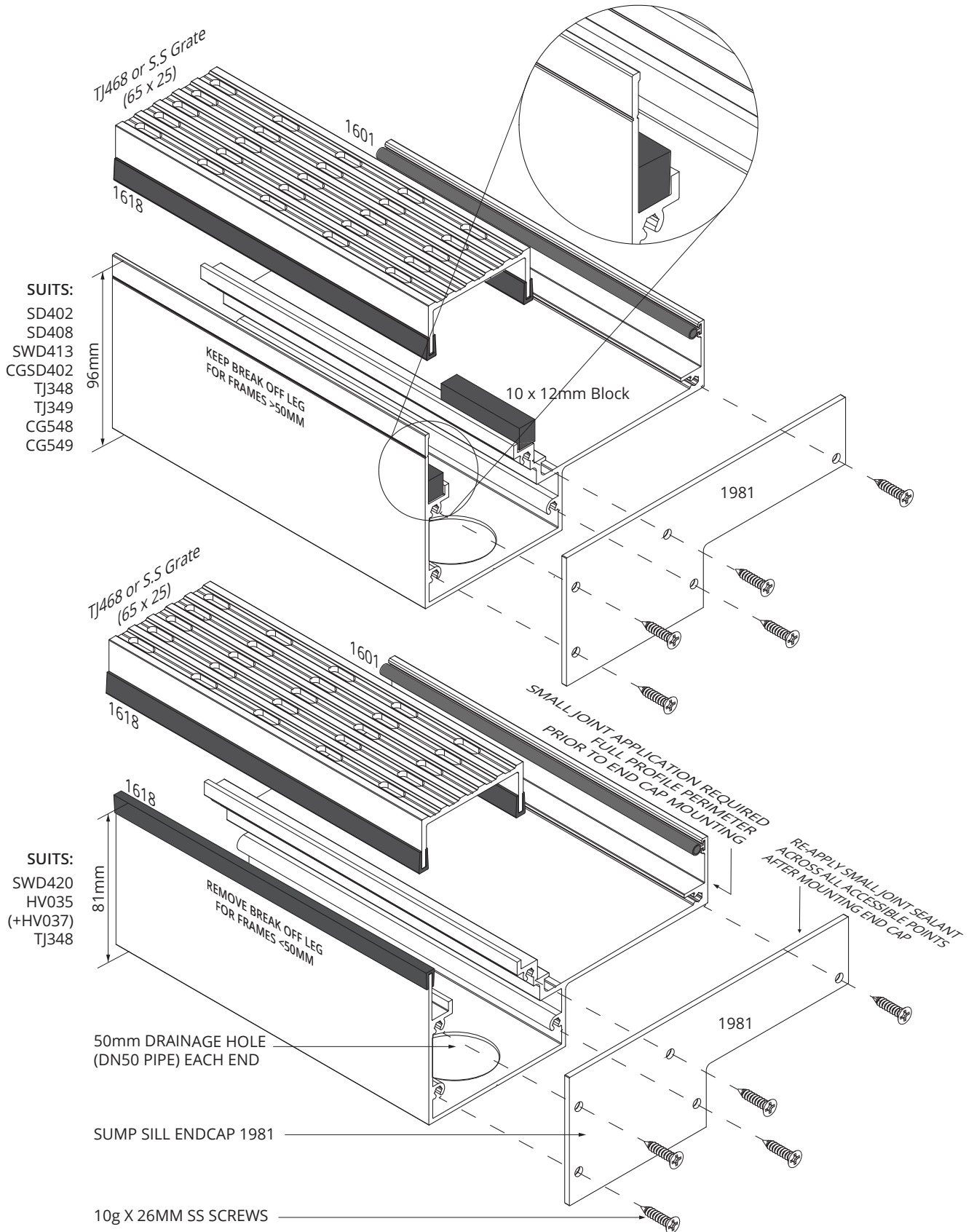

See also: Disclaimer and Copyright information on page 3

TJ400 Slab Recess Details (1:1)

All raw joints need to be sealed with small joint sealer or foam tab option.

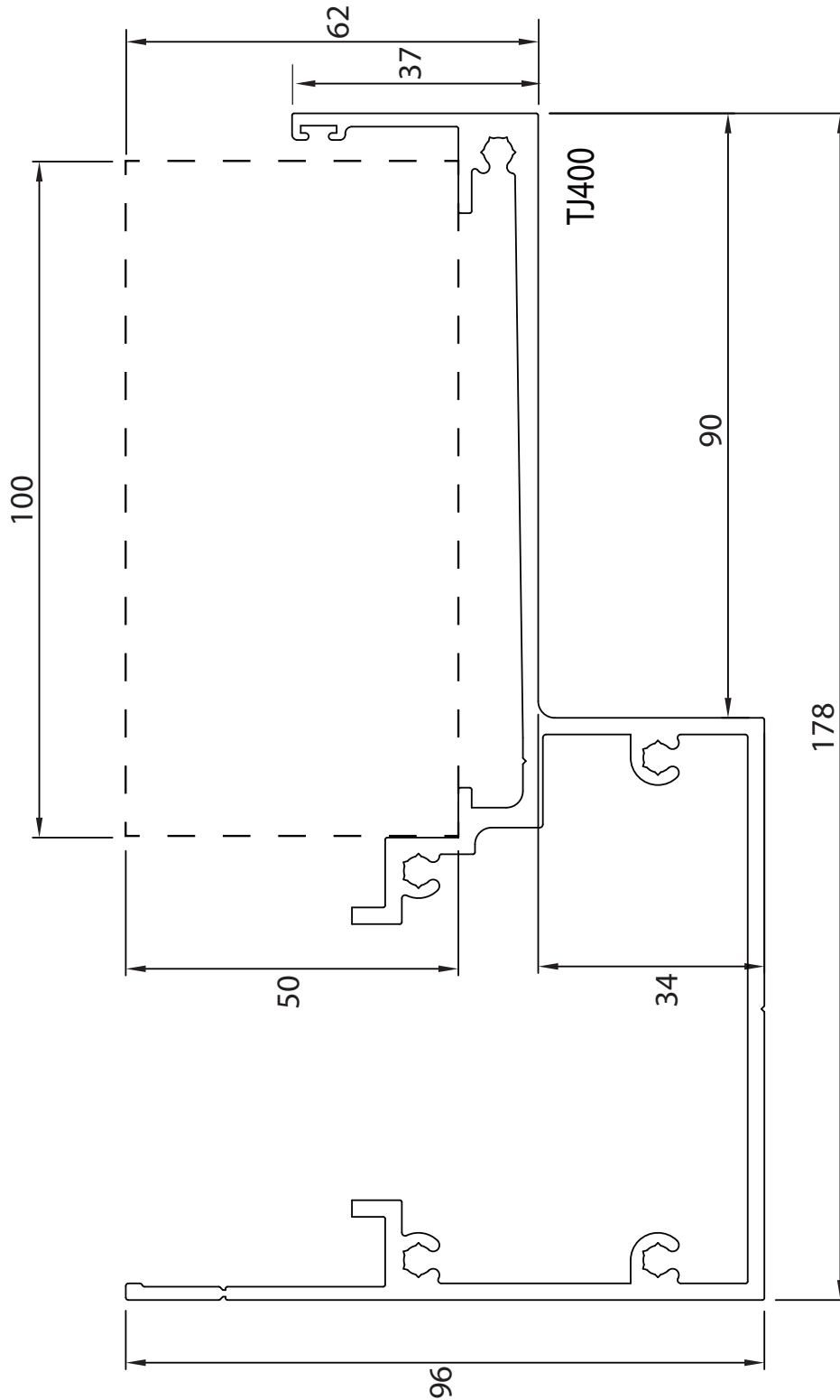

Fabrication

See also: Disclaimer and Copyright information on page 3

150mm Subhead Options

All raw joints need to be sealed with small joint sealer or foam tab option.

Fabrication

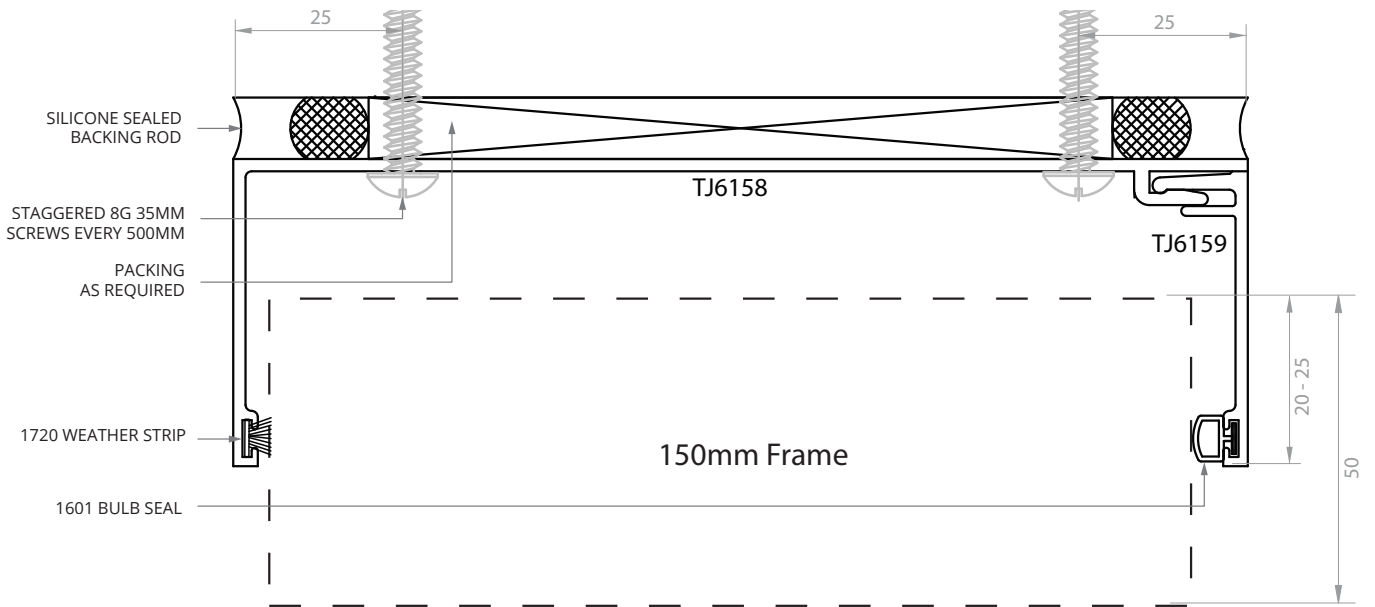
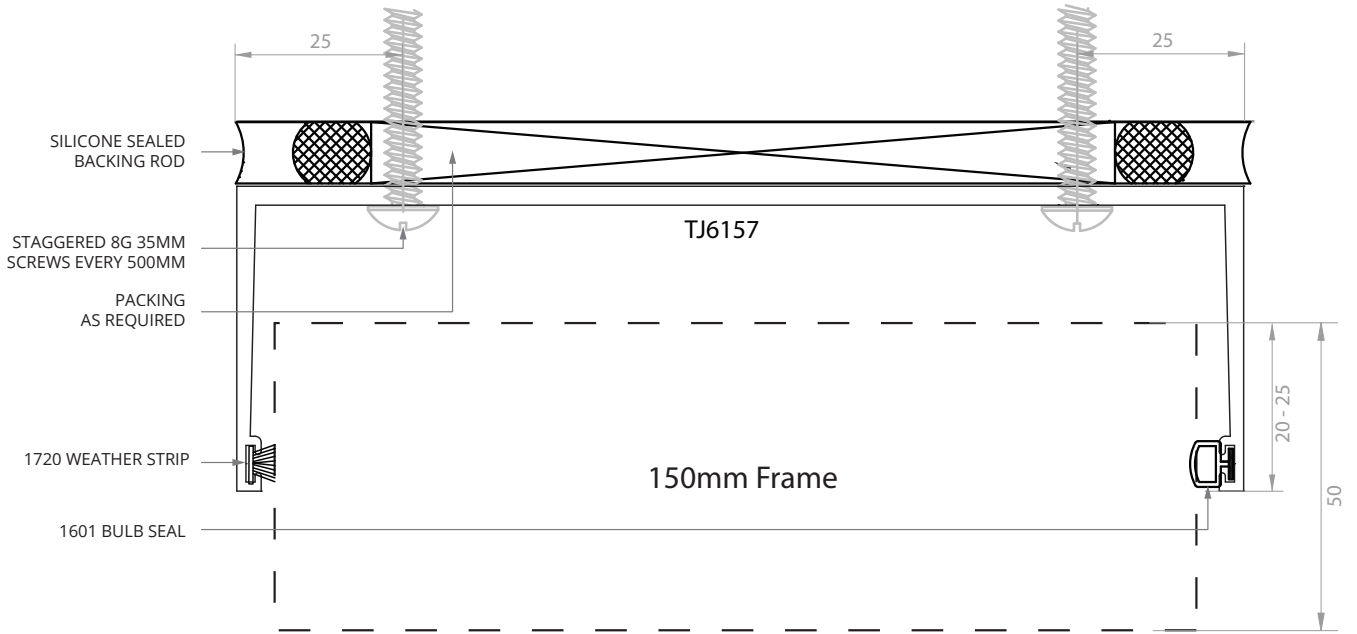

See also: Disclaimer and Copyright information on page 3

50MM HOOK AWNING

150mm SubJamb Options

All raw joints need to be sealed with small joint sealer or foam tab option.

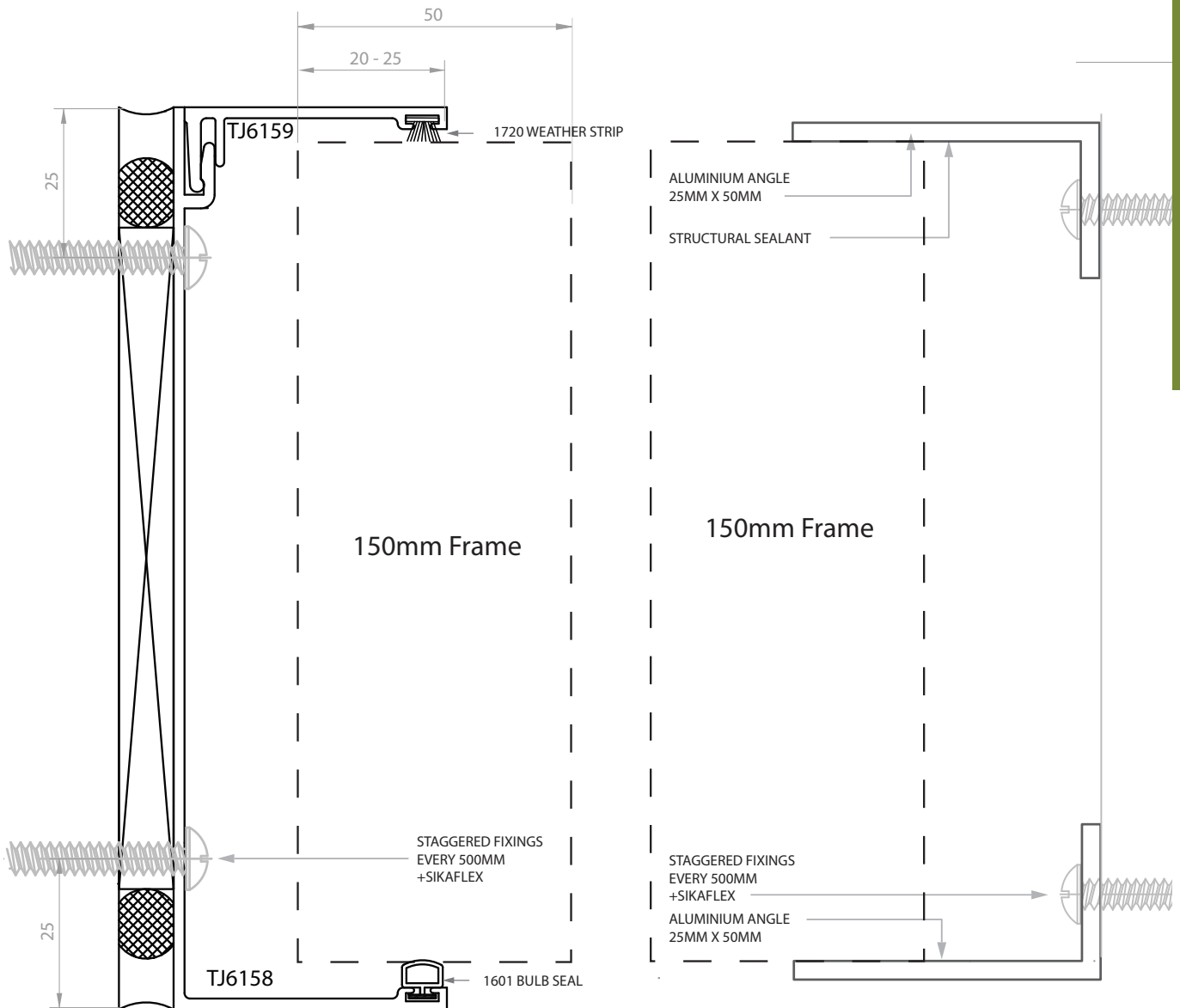

Fabrication

See also: Disclaimer and Copyright information on page 3

150mm Subframe Internal Bead

All raw joints need to be sealed with small joint sealer or foam tab option.

Fabrication

MACHINED (INTERNAL BEAD)

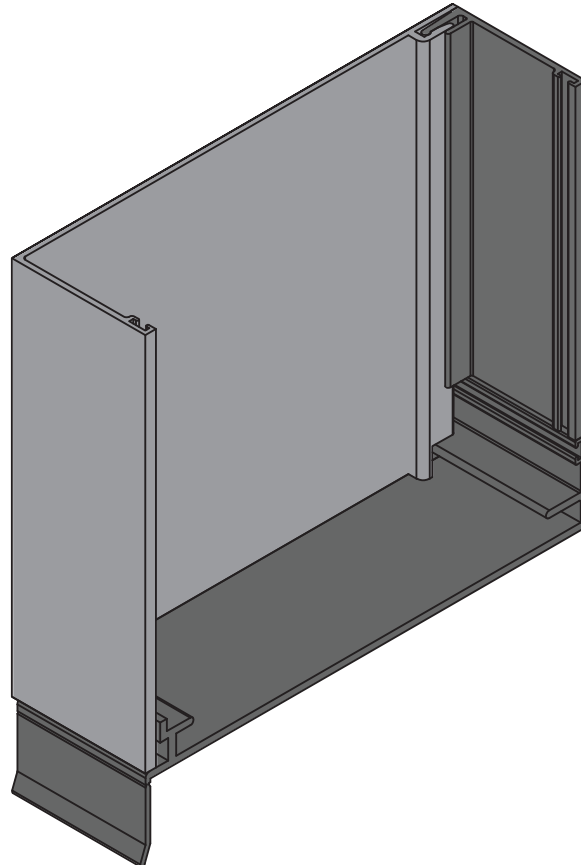
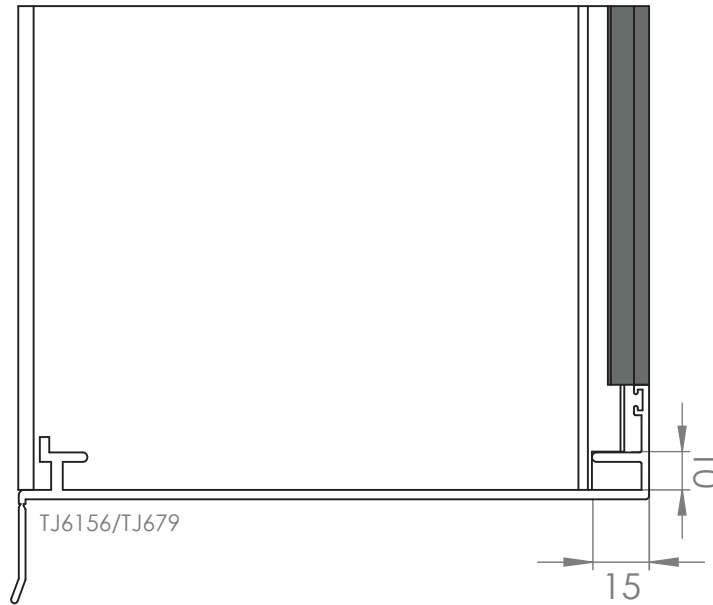

See also: Disclaimer and Copyright information on page 3

150mm Subframe External Bead

All raw joints need to be sealed with small joint sealer or foam tab option.

SQUARE CUT (EXTERNAL BEAD)

MACHINED (EXTERNAL BEAD)

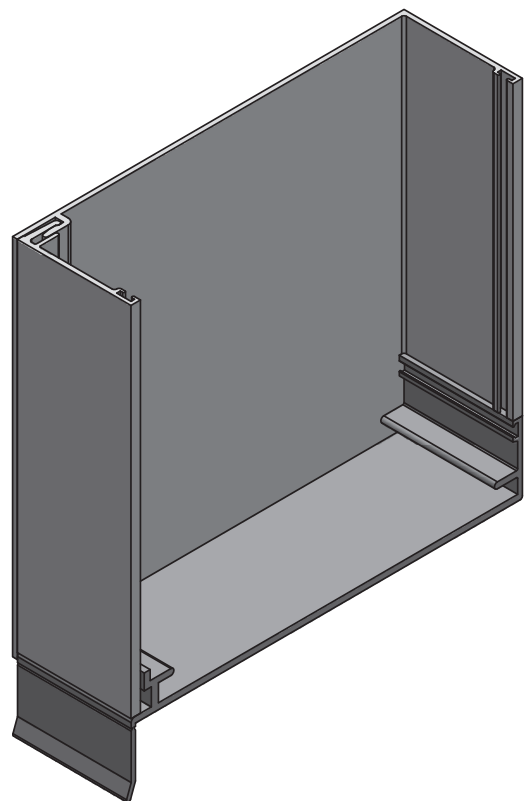
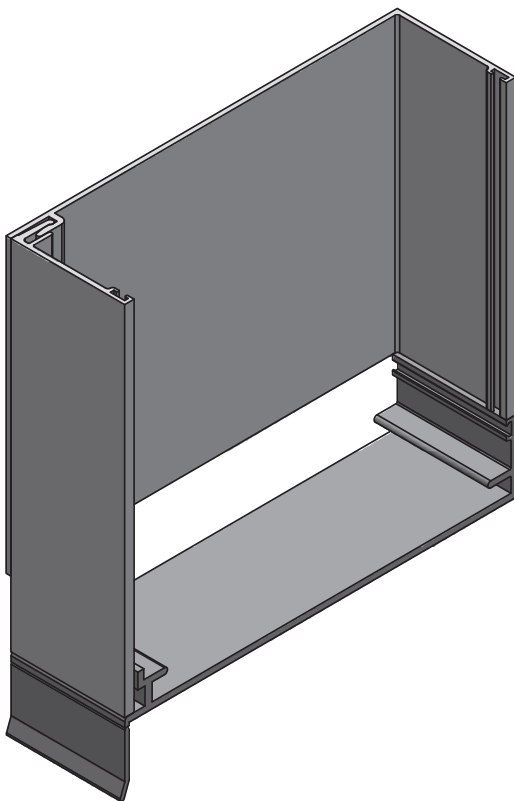
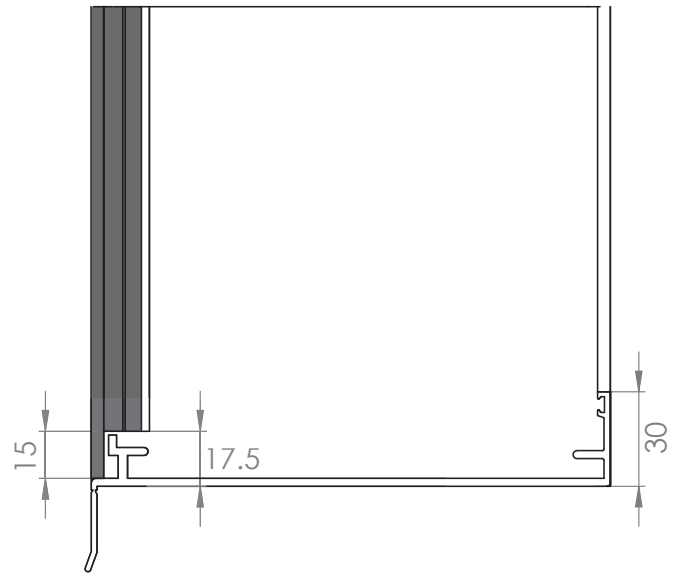
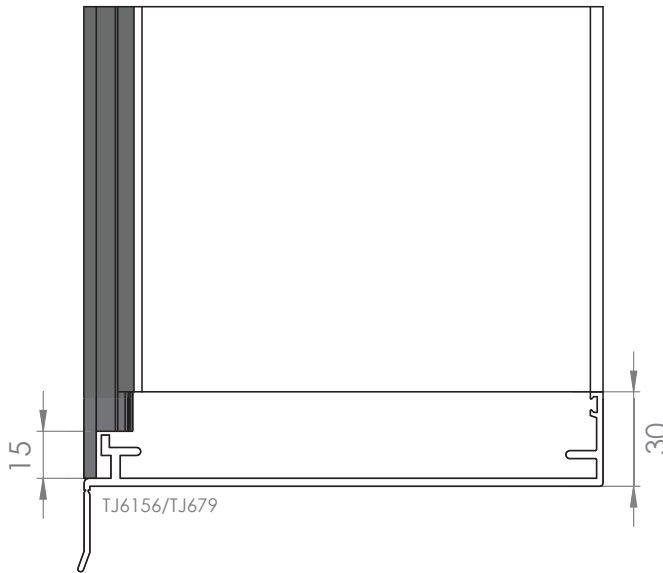

Fabrication

See also: Disclaimer and Copyright information on page 3

Subsill End-Dam Installation

All raw joints need to be sealed with small joint sealer or foam tab option.

Fabrication

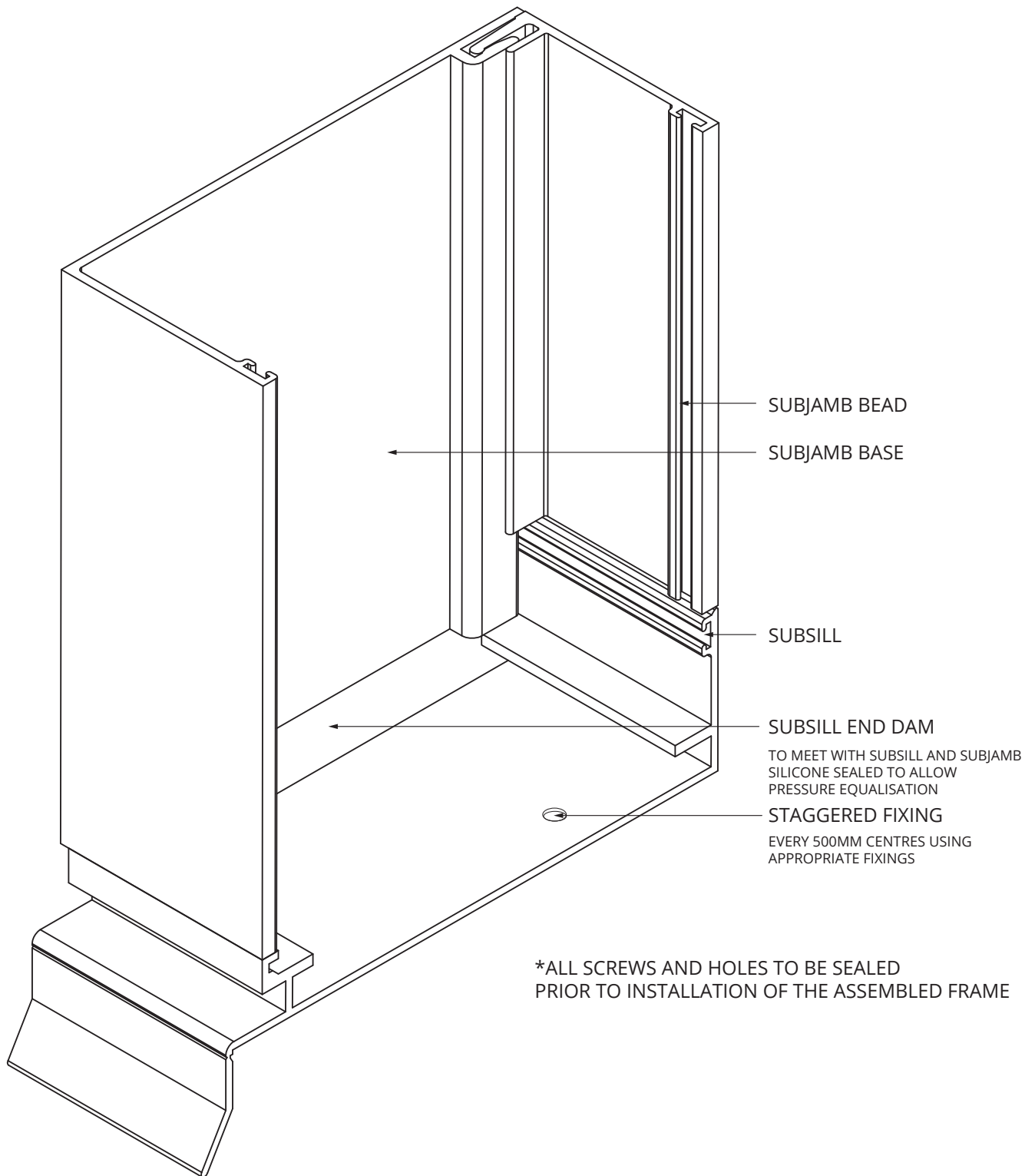

See also: Disclaimer and Copyright information on page 3

All raw joints need to be sealed with small joint sealer or foam tab option.

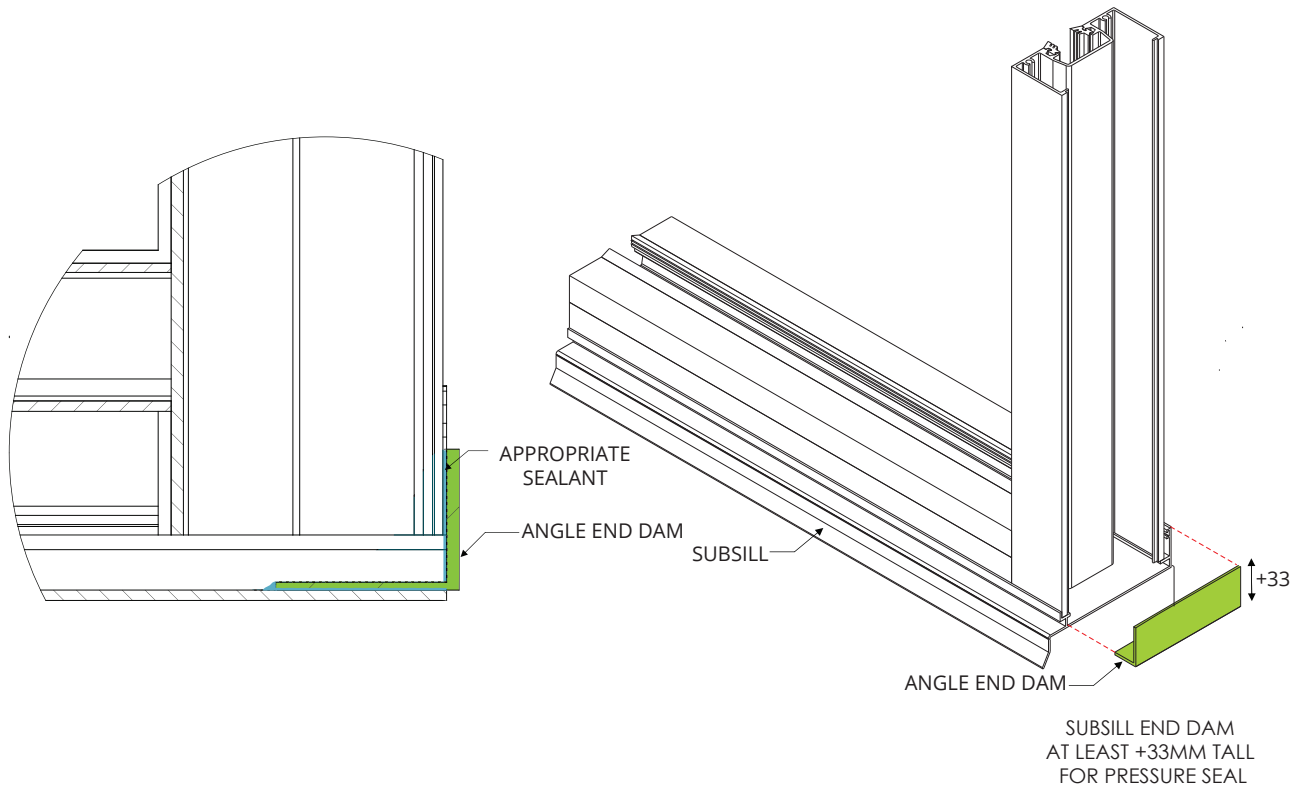
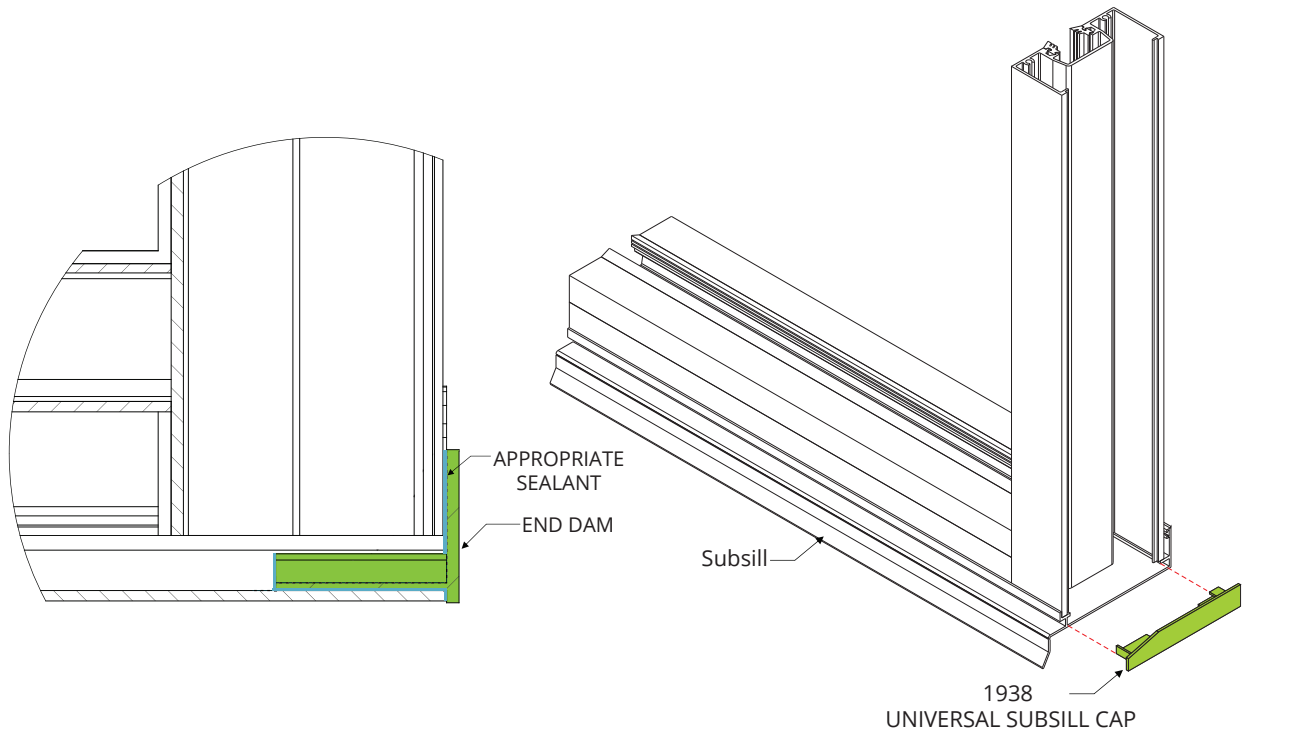

Fabrication

See also: Disclaimer and Copyright information on page 3

50MM HOOK AWNING

150mm Sump Sill

Fabrication

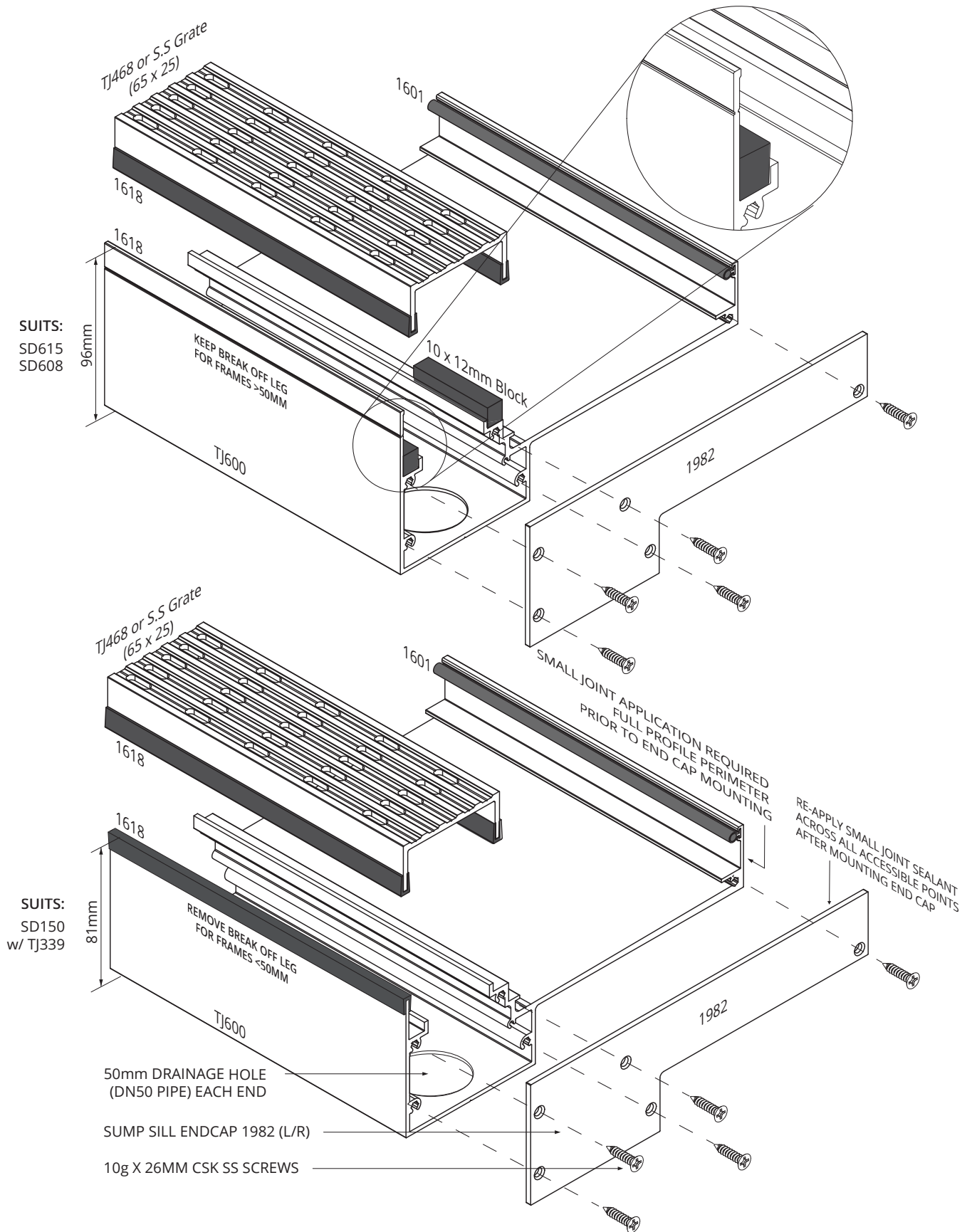

See also: Disclaimer and Copyright information on page 3

TJ600 Slab Recess Details (1:1)

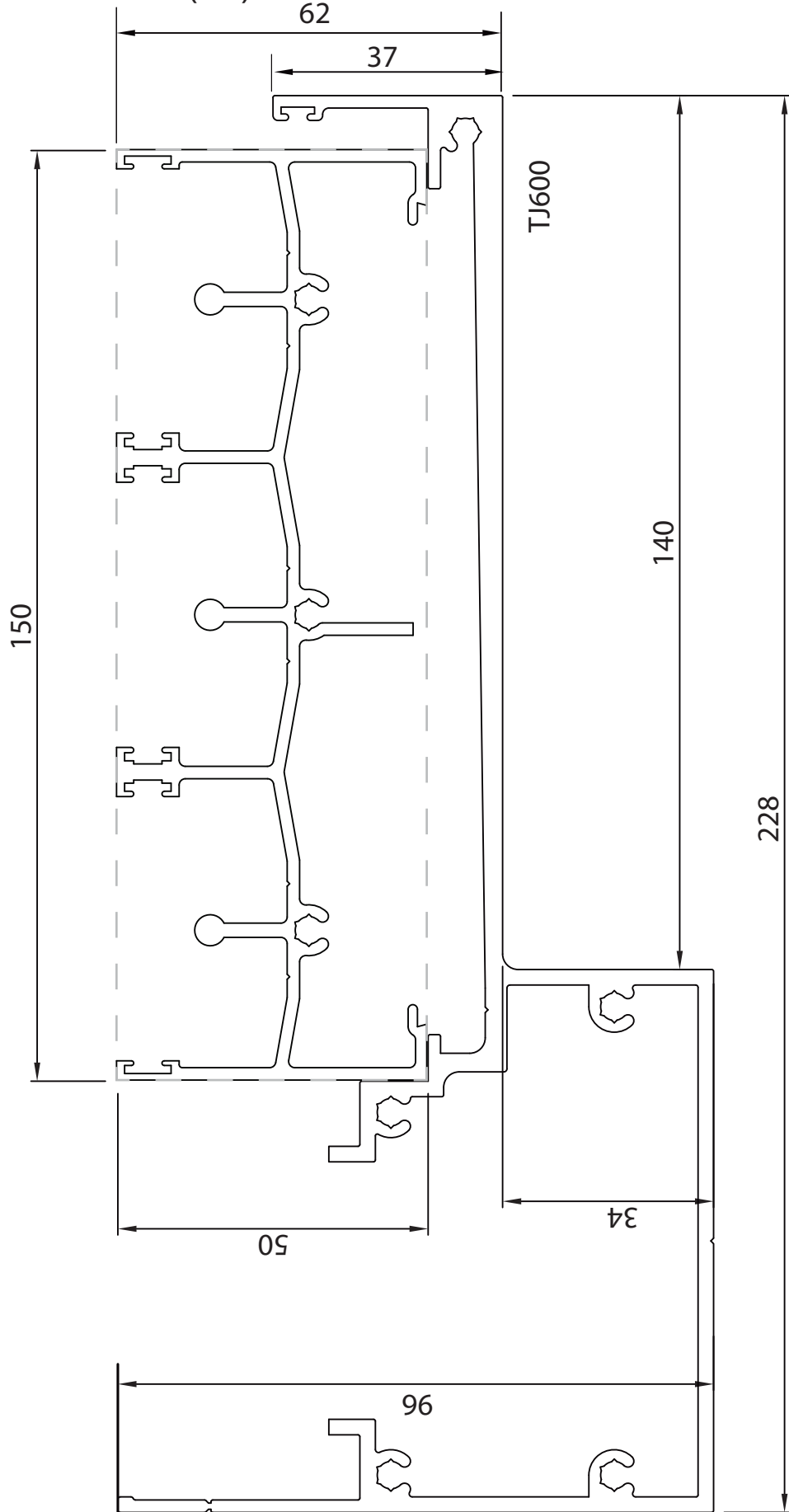

Fabrication

Tooling

BDX-CV-CSG/H/AW CSG Frame / Hinged /Hook Awning

CSG301	100mm Standard Main Frame	TJ435	114mm Open Pocket Hinge Stile
CSG303	CSG Bead	TJ436	114mm Open Pocket Lock Stile
CSG303B	CSG Sloped Bead	TJ437	114mm Open Pocket Plain Stile
CSG304	Glazing Adaptor	TJ440	73mm Open Pocket Lock Stile
CSG320	Standard Duty Self Mating Mullion	TJ441	73mm Open Pocket Hinge Stile
CSG333	Heavy Duty Self Mating Mullion	TJ443	73mm Open Pocket Sliding Stile
CSG360	100mm Centre Glazed Slim Frame	TJ444	73mm Open Pocket Plain Stile
CSG362	CSG Transom/Sill	TJ450	73mm Open Pocket Meeting Stile
CSG390	100mm Light Duty Frame	TJ451	114mm Open Pocket Lock Stile
CSG601	150mm Standard Main Frame	TJ452	114mm Open Pocket Hinge Stile
CSG603	CSG Bead	TJ453	114mm Open Pocket Sliding Stile
CSG604	Glazing Adaptor	TJ725	114mm Open Pocket Plain Stile
CSG633	Self Mating Mullion	TJ737	Flyscreen Adaptor/Winder Support
CDG4301	100mm Centre Double Glazed Main Frame	TJ742	Awning Stile/Rail
CDG4303	Sill Bead	TJ747	Hook Awning Sash Rail
CDG4303M	Sill Sloped bead	TJ749	Hook Awning Sash Stop
CDG4304	Glazing Adaptor		
CDG4310	Male Split Mullion		
CDG4311	Female Split Mullion		
CDG4312	H/D Male Split Mullion		
CDG4313	H/D Female Split Mullion		
CDG4314	Male Light Split Mullion		
CDG4315	Female Light Split Mullion		
CDG4390	Transom/Sill		
CDG6501	150mm Centre DG Main Frame		
CDG6503	Sill Bead		
CDG6504	Glazing Adaptor		
CDG6510	Male Split Mullion		
CDG6511	Female Split Mullion		
CDG6512	H/D Male Split Mullion		
CDG6513	H/D Female Split Mullion		
HV271	Door Stile		
HV272	Hinge Stile		
HV273	Large Rail		
HV275	Large DG Rail		
HV277	Small DG Rail		
HV289	Small Rail		
HV291	DG Stile		
HV322	Sliding Door stile		
TJ154	114mm Hinge Stile		
TJ155	114mm Lock Stile		
TJ158	114mm Pivot Stile		
TJ159	114mm Sliding Stile		
TJ311	Hinge Stile		
TJ312	Lock Stile		
TJ313	Door Top Rail		
TJ315	Door Bottom Rail		
TJ322	Sliding Door Stile		
TJ327	Meeting Stile		
TJ416	73mm Open Pocket Sliding Stile		
TJ417	73mm Open Pocket Hinge Stile		
TJ418	73mm Open Pocket Lock Stile		
TJ419	DG Top Rail		
TJ420	DG Bottom Rail		
TJ428	114mm Open Pocket Sliding Stile		

[BDX-CV-CSG/H/AW tool set information](#)

Weight	900kg
Dimensions	1420 x 1140 x 800mm (H x W x D)
Outrigger	Yes



Tooling

All raw joints need to be sealed with small joint sealer or foam tab option.

CARE & MAINTENANCE

KlassicView / CityView / ClimateGuard

Tooling Operation Manual

The following guidelines should be observed to ensure safe and efficient use, longevity and quality production.

All users are responsible for the safe operation and maintenance of tools.

- * Read the entire Manual before starting machinery. Machinery may cause serious injury if not correctly operated.
- * Never leave machine unattended. Turn power off and wait until machine has come to a complete stop before leaving the machine unattended.
- * Disconnect main power before servicing machine. Make sure all power switches are in the off position and air disconnected and make sure all moving parts have come to a complete stop.
- * Keep machine well-guarded. Do not remove guards and ensure all guards are in place prior to operation.
- * Electric pump will shut down to prevent further damage if there is not enough lubricant.

General Maintenance:

- * Please keep tooling lubricated. We recommend using kerosene poured into a spray bottle. Lubricate all pins & blades before starting the machine. (PIC 1)
- * We also recommend fortnightly cleaning and lubrication of the guide pins and bushes at the front and rear on both decks. (PIC 2)

Note! Do not use silicon based lubricant under any circumstances as this will build up on the cutting edges of the tool and result in shorter operating life and poor quality results.

Operation:

- * Check machine over before operating. Check machine for damaged parts, loose bolts, loose connections, keys and wrenches left on the machine and any other conditions that may affect the machines operation. Repair and replace damaged parts.
 - * Do not use extrusion that are not specified for this machine.
 - * Do not use burred, heavy coated or bent extrusions or force extrusions into the tool.
- Note that manufacturing tolerance on aluminium can vary. Never hit or force extrusions into die guides.*
- * While operating do not remove guards and always keep hands outside of the guards.
 - * Empty swarf trays when required to prevent build up obstructing clearance of discarded aluminium.

Periodically, the die and punches will need sharpening. This must be carried out by experienced toolmaker.

See also: Disclaimer and Copyright information on page 3

Tooling

All raw joints need to be sealed with small joint sealer or foam tab option.

CARE & MAINTENANCE

Exchange or replace die:

* This is only to be carried out by suitability qualified persons:

1. Switch off the machine and isolate power point. Removing front covers and swarf trays.
2. Remove top and bottom screws from the die. Carefully take out the old die block.
3. Reconnect the power and switch on the machine. Turn to INCHING MODE, press foot valve to ensure the machine desk is on lowest level.
4. Placing the new block and pins units inside and fixed back into their original positions, then release the inching mode back to operation mode.

Ordering procedure for Replacement or spare parts:

* Please provide following details to your sales representative

- Machine serial number:
- Port (DIE) location:
- List of extrusion involved:
- Take photo of the issues:

(PIC 1) Lubricate all dark grey areas fortnightly with kerosene

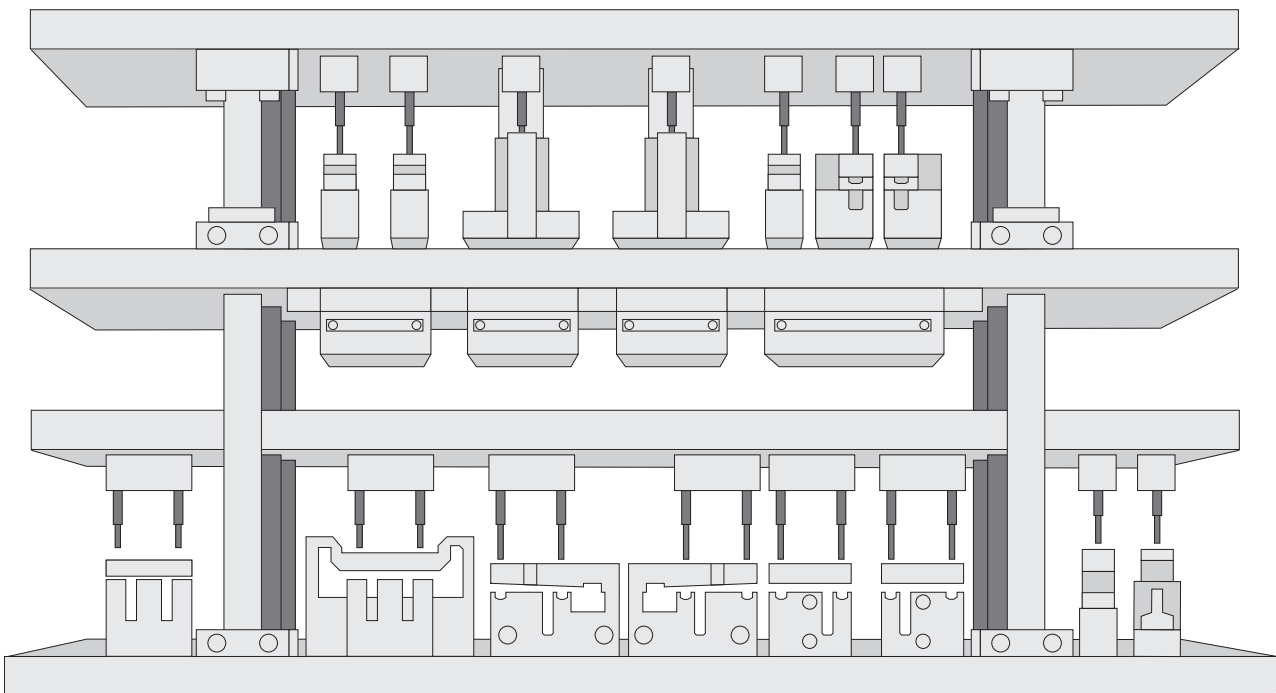

See also: Disclaimer and Copyright information on page 3

Maintenance & Warranty



Darley Aluminium

are long standing members of various industry associations including the Australian Glass & Window Association (AGWA) and the Window Energy Rating Scheme (WERS) and as such we conform to an Industry Code of Conduct designed to protect consumers.

Manufacturing Standards;

All aluminium extrusions supplied to by Darley Aluminium have been supplied in accordance with Australian Standard AS1866 - 'Aluminium and Aluminium alloy: Extruded rod, bar, solid and hollow shapes'. All Anodised and Painted Extrusions are as per AS1231 Aluminium and Aluminium Alloys - 'Anodic Oxidation Coatings' and AS3715 - 'Metal Finishing-Thermoset Powder Coatings for Architectural Applications of Aluminium and Aluminium Alloys'.

Product Testing and Compliance;

Darley Aluminium products are tested in NATA accredited independent laboratories to ensure they meet the relevant Australian Standards. Energy ratings can also be found on the Window Energy Rating Scheme (WERS) website:

<https://agwa.imiscloud.com/WERS/>

Maintenance & Warranty

Care & Maintenance

- A gentle wash with a soft non-abrasive brush or cloth using a mild detergent followed by a fresh water rinse will maintain the long term performance of the powder coat or anodised finish.
- If paint splashes, sealants or other residue need to be removed, then methylated spirits or white spirits can be applied with a soft cloth and gentle wiping only.
- In rural or normal urban environments, cleaning should occur at least every 12 months.
- In areas of pollution, industrial or coastal areas back one kilometre from the water, cleaning should occur at least every 3 months.
- In hazardous locations such as beachfronts, severe marine environments or areas of high industrial pollution, the frequency of cleaning should be increased to monthly.
- Special maintenance may be required in some extended warranty applications.

Tracks:

Keep tracks free from obstruction and excessive dirt or water.

Guides and Spindles:

To be greased with good quality automotive grease every 6 months.

Rollers:

As per manufacturer's instructions.

Hinges, Hangers & Flush Bolts:

Visible surfaces should be cleaned using a damp cloth and mild detergent, then wiped dry. Apply a light application of non-corrosive preventative lubricant to all surfaces and internals, using a dry cloth to remove excess. Repeat at intervals no greater than 3 months.

Seals and PVC Product:

An occasional wipe with a damp cloth or a wash with warm soapy water is all that is required.

Glass:

Simply wipe over the surface with a few drops of methylated spirits on a damp cloth, then polish the surface with a dry, lint-free, non-abrasive cloth.

Ver 3: August 2023



SYDNEY HEAD OFFICE

8 Tyrone Place, Erskine Park NSW 2759
Tel: (02) 8887 2888
Fax: (02) 9834 3244
Email: sales@darleyaluminium.com.au

MELBOURNE

10 Bridge Road, Keysborough VIC 3173
Tel: (03) 9238 3888
Fax: (03) 9768 7288
Email: salesvic@darleyaluminium.com.au

BRISBANE

29 Access Avenue, Yatala QLD 4207
Tel: (07) 3287 1888
Fax: (07) 3287 2088
Email: salesqld@darleyaluminium.com.au

PERTH

36 Armstrong Road, Hope Valley WA 6165
Tel: (08) 9437 2999
Fax: (08) 9437 1024
Email: saleswa@darleyaluminium.com.au

darleyaluminium.com.au



AUSTRALIAN
**GLASS &
WINDOW**
ASSOCIATION
MEMBER