

## 35mm Awning Window System



SLS - 1200 Pa  
ULS - 3000 Pa



Air - 0.21L  
Water - 500 Pa



Acoustic - Rw 38  
10.38mm Laminate



Fire Rating  
Tested - BAL 40



Single glazed  
U VALUE 5.59 to 6.80  
SHGC 0.22 to 0.53  
TVW 0.05 to 0.52

Double glazed  
U VALUE 3.95 to 4.92  
SHGC 0.13 to 0.50  
TVW 0.04 to 0.49

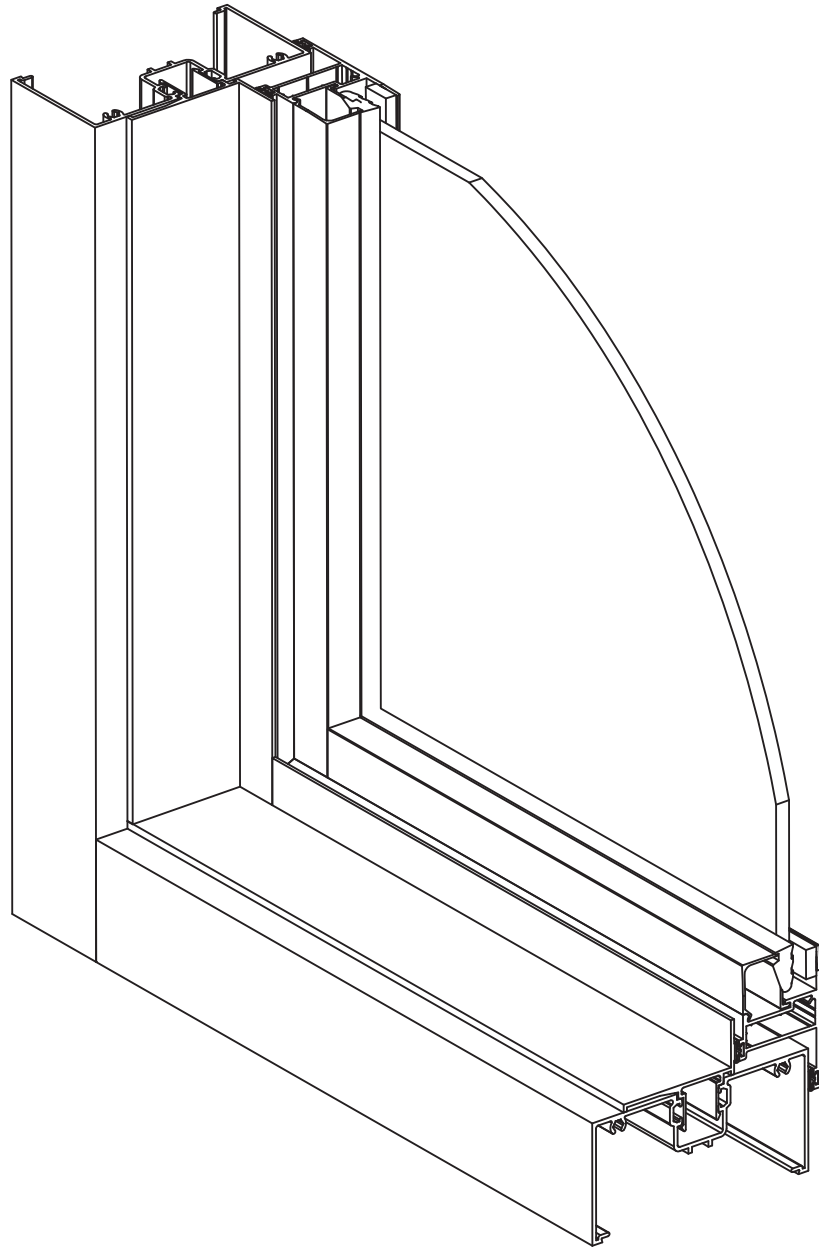

53mm

**76mm**

100mm

150mm

165mm

200mm

250mm



12mm Glass  
Coverage



Max  
24mm



Subsill  
Draining



Transom  
Draining



## Disclaimer

Darley Aluminium strives to ensure the technical details contained in this manual are complete and correct. Occasionally, some errors or outdated information may require rectification - Darley Aluminium takes no responsibility for any loss or damage as a result of these errors. If you are unsure of any information provided within this manual, please contact your nearest Darley Aluminium office.

Engineering, manufacture and installation of frames must meet requirements of AS2047 (Windows in Buildings).

Glazing selected must meet requirements of AS 1288 (Glass in Buildings).

Size limitations are governed by design intent, glass selection, and local wind load requirements as per AS/NZS 1170.2 (Wind Actions) or AS 4055 (Wind Loads for Housing). An Engineer should be consulted to ensure selected framing and installation meets the requirements as set out by the relevant Australian Standards.

Any reference to an Australian Standard within this manual is based on the interpretations of Darley Aluminium. Code Compliance responsibility remains with the user of this manual. Misuse or misinterpretation of the information in this manual or of the Australian Standards remains the responsibility of the user of this manual.

Engineering, manufacture and installation must meet requirements of AS 2047, AS3959, WERS and Acoustic requirements. Glazing selected must meet requirements of AS 1288. Size limitations are governed by design intent, glass selection, and local wind load requirements as per AS/NZS 1170.2 or AS 4055.

N.B.- For frames, designs, and configurations outside the tested scope, an engineer or suitably qualified person should be consulted.

## Copyright

This technical manual and the information within remains the property of Darley Aluminium. The manual must not be reproduced, copied or loaned without prior agreements with Darley Aluminium.

# Contents

<b>Introduction</b>	<b>5</b>
<b>Welcome</b> .....	<b>5</b>
Overview.....	5
Design Features.....	5
Performance Summary .....	5
System Requirements.....	5
<b>1:1 Section Profiles</b> .....	<b>6</b>
<b>Adaptors</b> .....	<b>15</b>
<b>Hardware</b> .....	<b>18</b>
<b>Performance</b>	<b>23</b>
<b>Performance Summary</b> .....	<b>23</b>
<b>Test Results</b> .....	<b>24</b>
Acoustic Test Report .....	29
BAL Compliance .....	31
<b>Glazing</b>	<b>32</b>
<b>Glass &amp; Rubber Combinations</b> .....	<b>32</b>
<b>Energy Ratings</b> .....	<b>33</b>
<b>General Configuration</b> .....	<b>38</b>
<b>Fabrication</b>	<b>38</b>
<b>Machining</b> .....	<b>56</b>
Cutting Formula.....	56
<b>Component Assembly</b> .....	<b>63</b>
<b>Sub-Framing</b> .....	<b>65</b>
100mm Subframe Details .....	65
150mm Subframe Details .....	73
<b>Tooling</b> .....	<b>83</b>
<b>Appendix</b>	<b>84</b>
<b>Maintenance &amp; Warranty</b> .....	<b>84</b>
<b>Release Notes</b> .....	<b>86</b>

## Welcome

### Overview

Darley's Awning Window System is the ideal choice for modern architectural requirements, meeting current design trends as well as performance specifications. The system is ideally suited for shopping centres, offices, show rooms, and commercial buildings. It is also widely used in high-end residential developments and apartments. Framing options include 76/100/101.6/150mm Front and Centre Glazed Combinations. Glazing ranging from 6mm to 24mm can be installed with the options of various beads to suit. All Darley framing systems are available in powder coat and anodised finishes. (Refer to Darley Aluminium Product Catalogue for further information)

### Design Features

- Accepts glass thickness from 6mm to 24mm.
- Compatible with other Darley Aluminium Commercial Systems
- Self-draining transom
- Accepts a variety of awning sash options (refer to awning section)
- Range of heavy-duty mullion options for tall framing and high-wind areas
- Max sash height = 1700mm
- Max sash width = 950mm
- Side Stays (13mm Stack):
  - 14kg Max for heights under 450mm
  - 20kg Max for heights 450 - 550mm
  - 24kg Max for heights 500 - 1200mm
  - 35kg max for heights 1200 - 1800mm
- Top hook-hinge:
  - 20kg Max for widths 400mm - 600mm
  - 45kg Max for widths 600mm - 1080mm
- Tested and Approved by an independent NATA accredited laboratory

### Performance Summary

Performance Summary							
Sash Size	SLS	ULS	Water	Air Infiltration	Acoustic	BAL	Glass
600 - 1633mm H 600 - 1080mm W	1200pa	3000pa	500	+ 0L/s m <sup>2</sup> - 0.21L/s m <sup>2</sup>	36 Rw	Bal40	Max 24mm

### System Requirements

- Engineering, manufacture and installation of frames must meet requirements of:
  - AS2047-2048 (Windows and External Glazed Doors in Buildings)
- Glazing selected must meet requirements of AS1288 (Glass in Buildings - Selection and Intallation)

## Mainframe Profiles

Scale 1:1

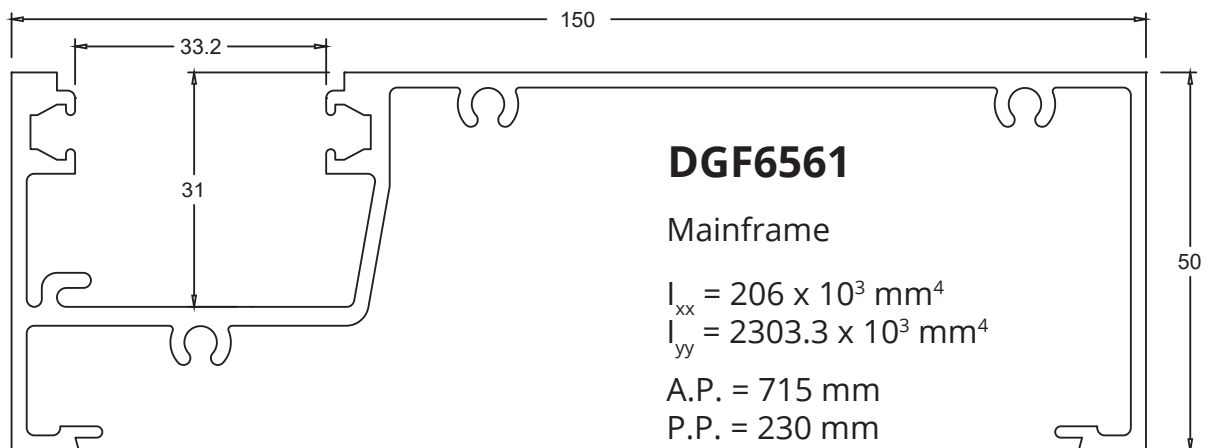
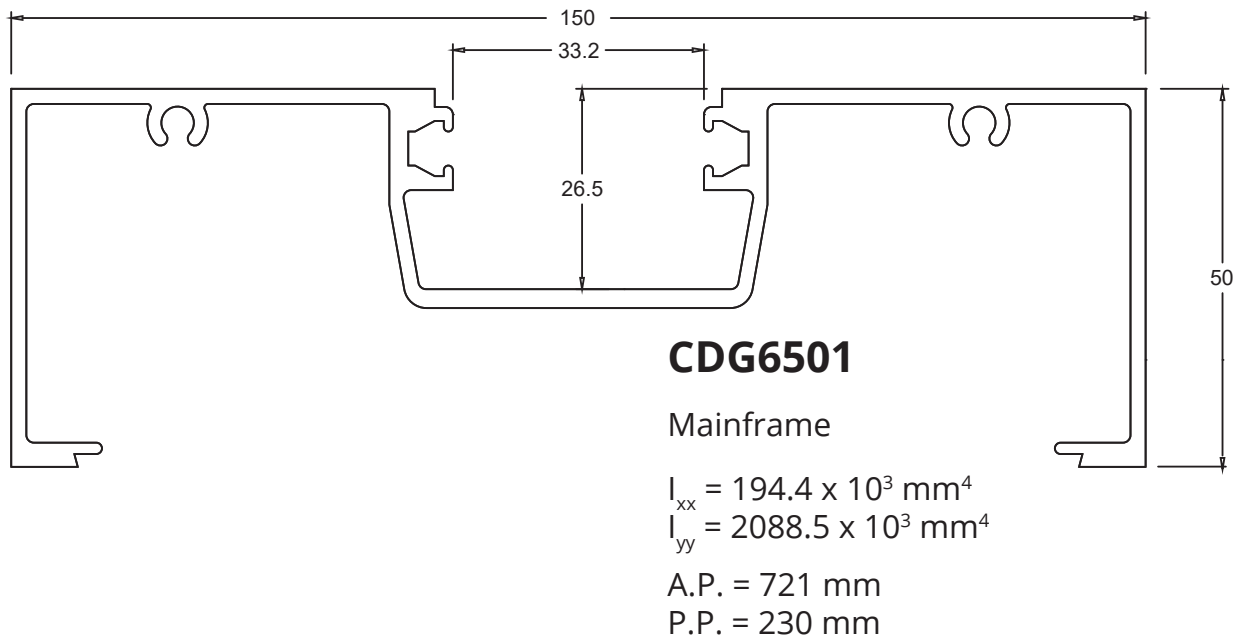
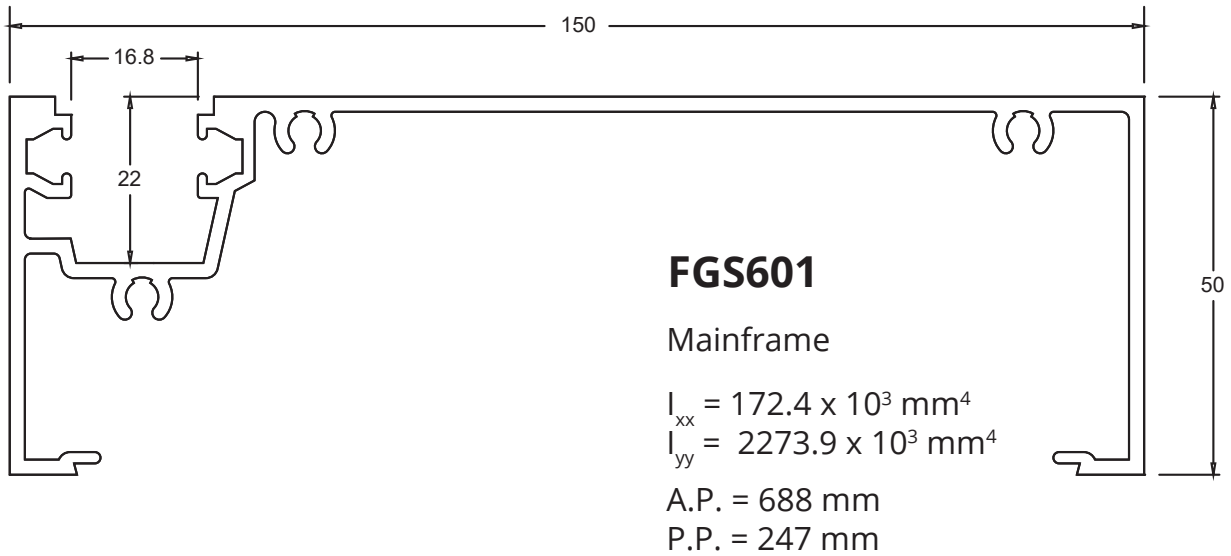

Mainframe Profiles

Scale 1:1

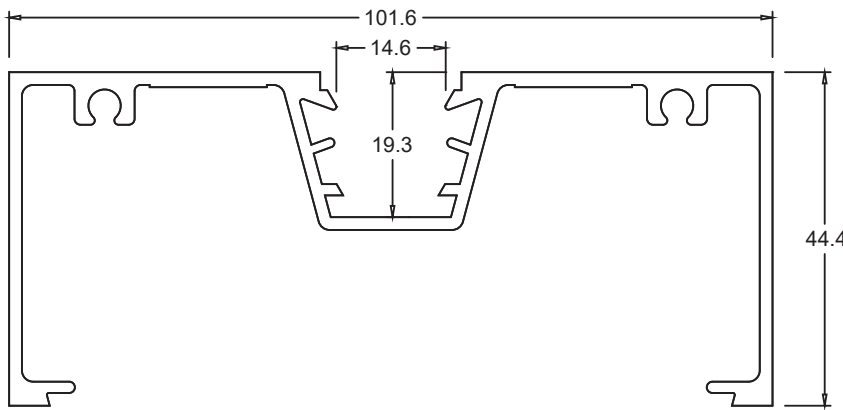

**TJ301**

Standard Mainframe

$I_{xx} = 98.29 \times 10^3 \text{ mm}^4$   
 $I_{yy} = 677.94 \times 10^3 \text{ mm}^4$

A.P. = 541 mm  
 P.P. = - mm

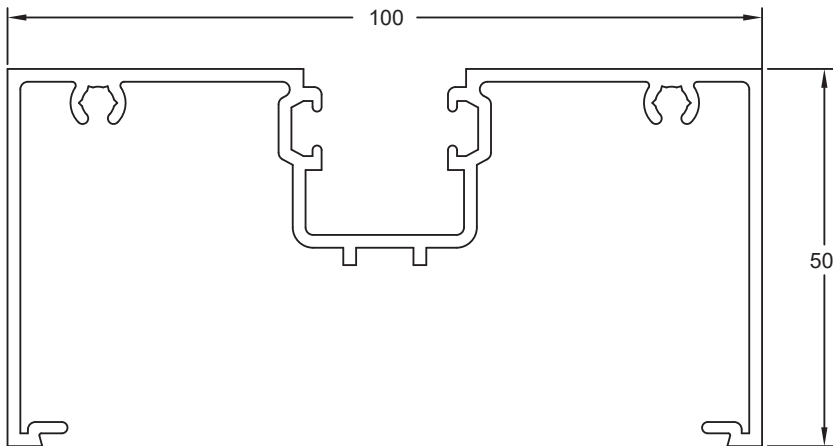

**CSG301**

Standard Mainframe

$I_{xx} = 117 \times 10^3 \text{ mm}^4$   
 $I_{yy} = 658.8 \times 10^3 \text{ mm}^4$

A.P. = 594 mm  
 P.P. = 188 mm

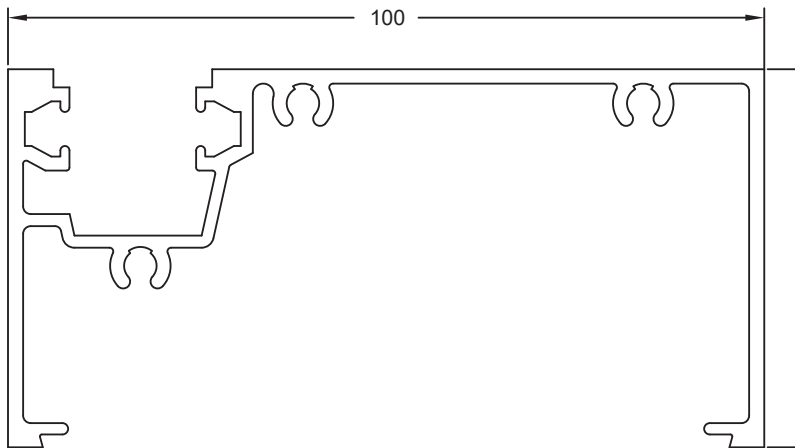

**FGS401**

Mainframe

$I_{xx} = 148.8 \times 10^3 \text{ mm}^4$   
 $I_{yy} = 835.4 \times 10^3 \text{ mm}^4$

A.P. = 589 mm  
 P.P. = 198 mm

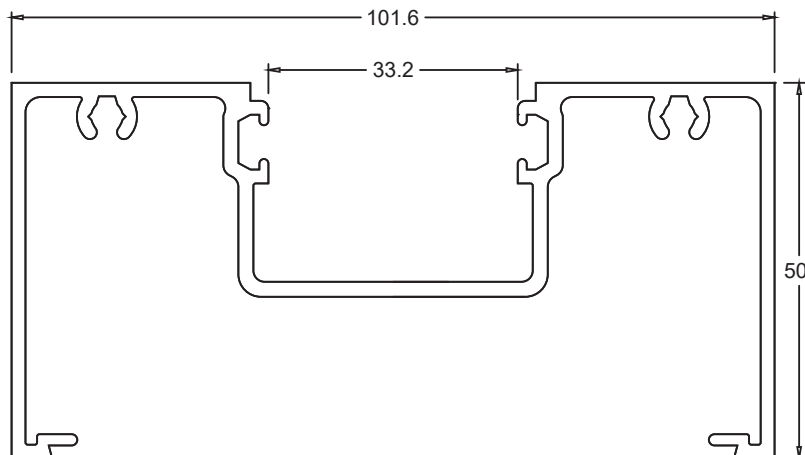

**CDG4301**

Mainframe

$I_{xx} = 148.8 \times 10^3 \text{ mm}^4$   
 $I_{yy} = 880.4 \times 10^3 \text{ mm}^4$

A.P. = 611 mm  
 P.P. = 174 mm

## Mainframe Profiles

Scale 1:1

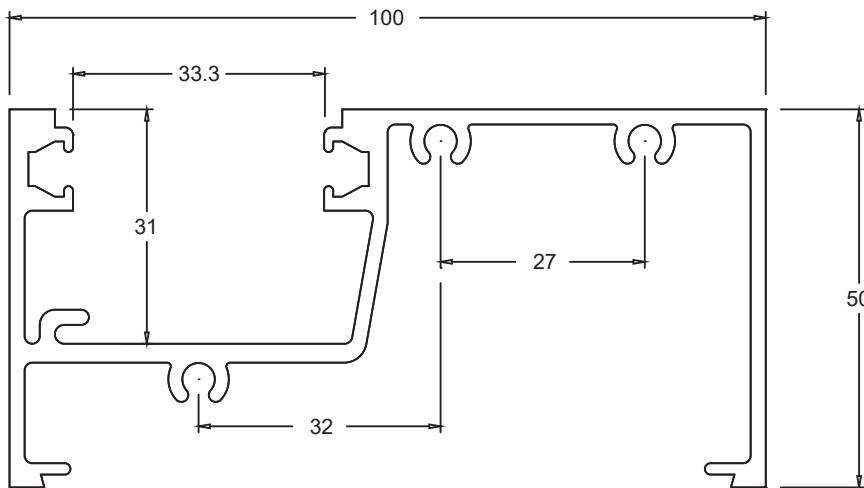
**DGF4501**

Mainframe

$$I_{xx} = 160.2 \times 10^3 \text{ mm}^4$$

$$I_{yy} = 852.9 \times 10^3 \text{ mm}^4$$

A.P. = 595 mm

P.P. = 171 mm

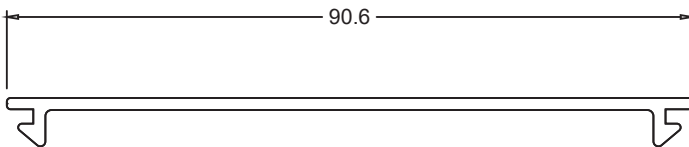
**TJ305**Frame Filler For 100mm  
Frame

A.P. = 206 mm

P.P. = 100 mm

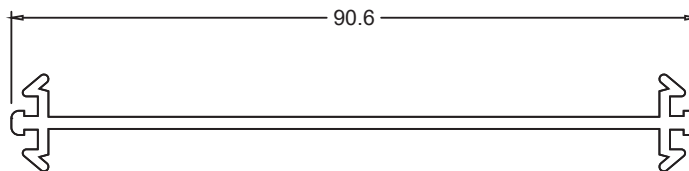
**TJ385**Back To Back Adaptor  
For 100mm Frame

A.P. = 247 mm

P.P. = - mm

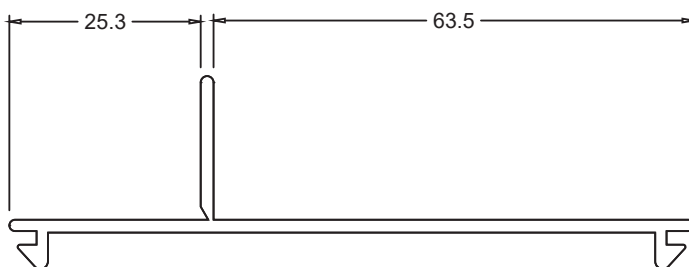
**TJ342**Frame Reveal Adaptor  
For 100mm Frame

A.P. = 244 mm

P.P. = 130 mm

Additional Profiles

Scale 1:1

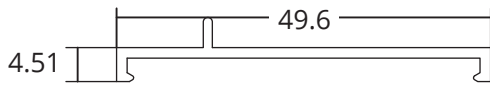

**TJ732**

Electric Chainwinder Cover

A.P. = 124 mm  
P.P. = 100 mm

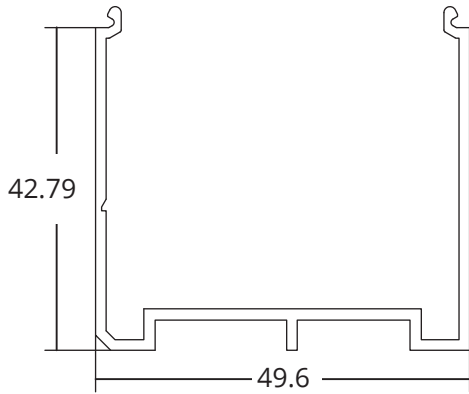

**TJ731**

Electric Chainwinder Base

A.P. = 309 mm  
P.P. = 150 mm

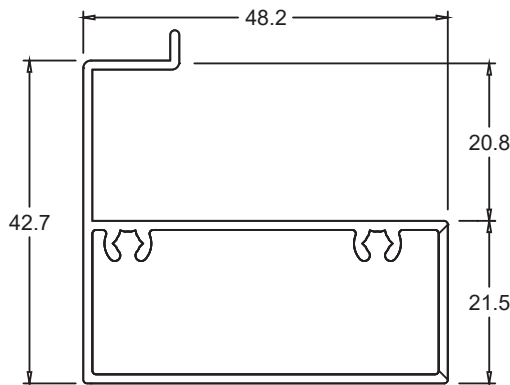

**TJ734**

Chain Winder Adaptor

$I_{xx} = 38.36 \times 10^3 \text{ mm}^4$   
 $I_{yy} = 70.02 \times 10^3 \text{ mm}^4$

A.P. = 211 mm  
P.P. = 211 mm

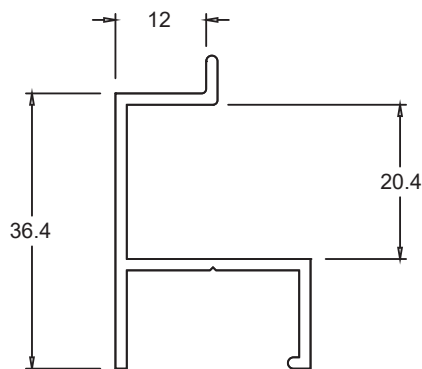

**TJ737**

Chain Winder Adaptor

$I_{xx} = 25.95 \times 10^3 \text{ mm}^4$   
 $I_{yy} = 14.71 \times 10^3 \text{ mm}^4$

A.P. = 208 mm  
P.P. = 100 mm

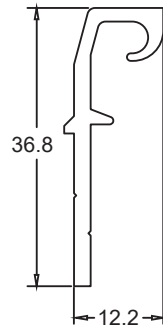
**TJ725**

Awning Sash Hinge  
(Fits with TJ724)

$$I_{xx} = 0.796 \times 10^3 \text{ mm}^4$$

$$I_{yy} = 14.5 \times 10^3 \text{ mm}^4$$

A.P. = 45.05 mm  
P.P. = 216.7 mm

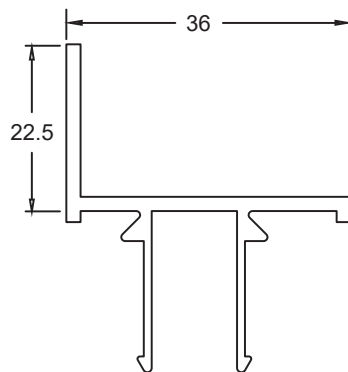
**TJ720**

Cityview Awning Stop  
(Fits 101.6mm CSG)

$$I_{xx} = 8.24 \times 10^3 \text{ mm}^4$$

$$I_{yy} = 21.75 \times 10^3 \text{ mm}^4$$

A.P. = - mm  
P.P. = - mm

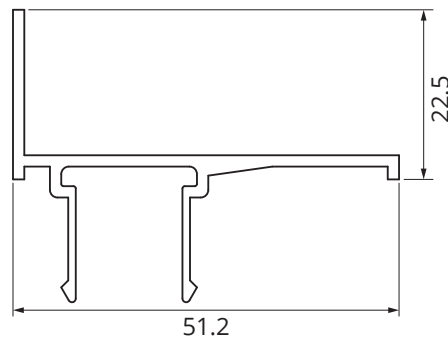
**CSG720**

35mm Awning Stop

$$I_{xx} = 6.1 \times 10^3 \text{ mm}^4$$

$$I_{yy} = 16.1 \times 10^3 \text{ mm}^4$$

A.P. = 160 mm  
P.P. = - mm

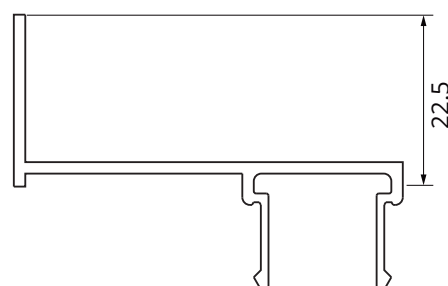
**CSG620**

35mm Awning Stop

$$I_{xx} = 6.1 \times 10^3 \text{ mm}^4$$

$$I_{yy} = 16.1 \times 10^3 \text{ mm}^4$$

A.P. = 224 mm  
P.P. = 100 mm

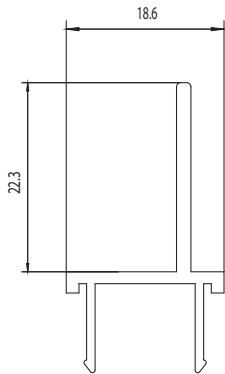

### TJ730

Cityview Awning Stop  
(Fits 76mm CSG)

$$I_{xx} = 6.597 \times 10^3 \text{ mm}^4$$

$$I_{yy} = 2.305 \times 10^3 \text{ mm}^4$$

A.P. = 130 mm  
P.P. = 100 mm

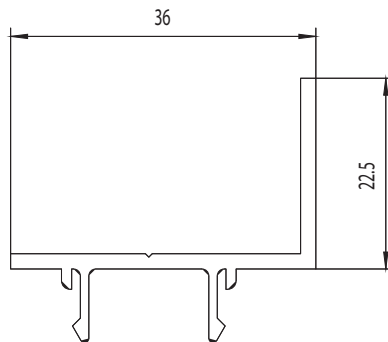

### FGS416

Cityview Awning Stop (Fits  
100mm FSG & 150mm FSG)

$$I_{xx} = 6.092 \times 10^3 \text{ mm}^4$$

$$I_{yy} = 16.884 \times 10^3 \text{ mm}^4$$

A.P. = 160 mm  
P.P. = 100 mm

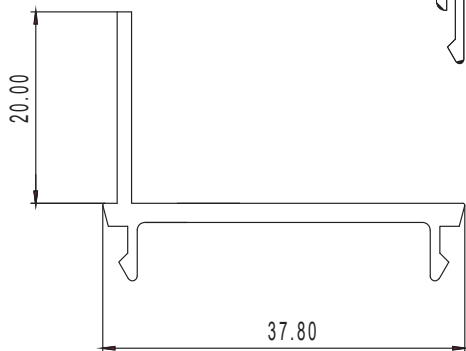

### CDG4316

Cityview Awning Stop  
(Fits 100mm CDG)

$$I_{xx} = 4.363 \times 10^3 \text{ mm}^4$$

$$I_{yy} = 19.169 \times 10^3 \text{ mm}^4$$

A.P. = 143 mm  
P.P. = 100 mm

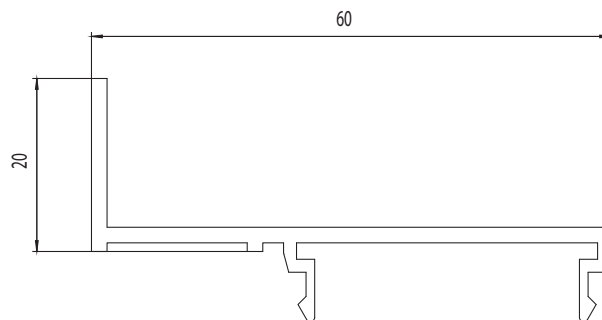

### CDG6516

Cityview Awning Stop  
(Fits 150mm CDG)

$$I_{xx} = 4.366 \times 10^3 \text{ mm}^4$$

$$I_{yy} = 69.176 \times 10^3 \text{ mm}^4$$

A.P. = 206 mm  
P.P. = 100 mm

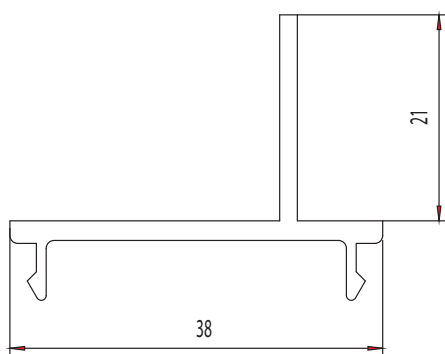

### DGF4516

Cityview Awning Stop (Fits  
100mm FDG & 150mm  
FDG)

$$I_{xx} = ? \times 10^3 \text{ mm}^4$$

$$I_{yy} = ? \times 10^3 \text{ mm}^4$$

A.P. = 145 mm  
P.P. = 100 mm

## Sash Profiles

Scale 1:1

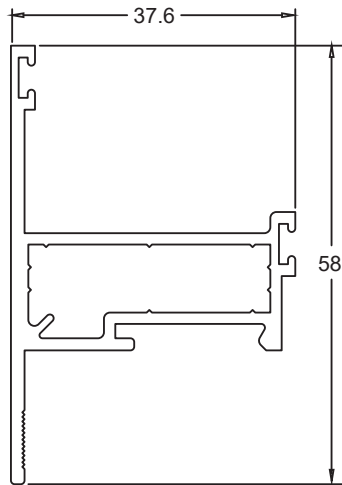
**TJ723**

Awning Sash with Flat Face

$$I_{xx} = 42.18 \times 10^3 \text{ mm}^4$$

$$I_{yy} = 104.78 \times 10^3 \text{ mm}^4$$

A.P. = 229 mm

P.P. = 140 mm

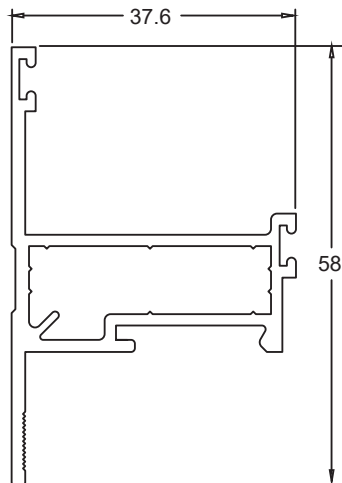
**TJ722**

Awning Sash with Grooved Face

$$I_{xx} = 42.44 \times 10^3 \text{ mm}^4$$

$$I_{yy} = 103.87 \times 10^3 \text{ mm}^4$$

A.P. = 229 mm

P.P. = 150 mm

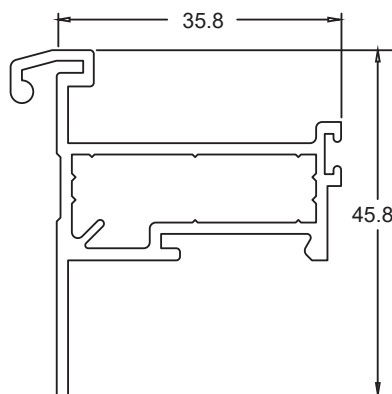
**TJ724**

Awning Hinged Sash

$$I_{xx} = 32.09 \times 10^3 \text{ mm}^4$$

$$I_{yy} = 106.34 \times 10^3 \text{ mm}^4$$

A.P. = 227 mm

P.P. = 150 mm

Sash Profiles

Scale 1:1

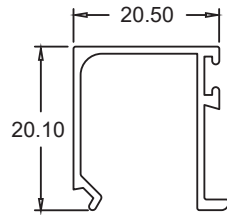

**TJ709**

Awning Bead (Suits 6-10mm Glazing)

$$I_{xx} = 4.8 \times 10^3 \text{ mm}^4$$

$$I_{yy} = 5.46 \times 10^3 \text{ mm}^4$$

A.P. = 147 mm  
P.P. = 100 mm

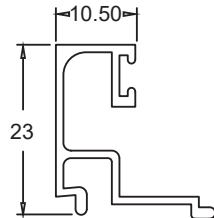

**TJ713**

Awning Bead (Suits 12-18mm Glazing)

$$I_{xx} = 5.03 \times 10^3 \text{ mm}^4$$

$$I_{yy} = 2.64 \times 10^3 \text{ mm}^4$$

A.P. = 146 mm  
P.P. = 100 mm

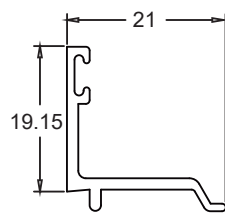

**TJ016**

Awning Bead (Suits 20-24mm Glazing)

$$I_{xx} = 1.04 \times 10^3 \text{ mm}^4$$

$$I_{yy} = 3.9 \times 10^3 \text{ mm}^4$$

A.P. = 96 mm  
P.P. = 100 mm

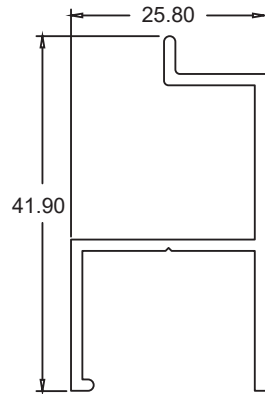
**TJ737**

Flyscreen Adaptor

$$I_{xx} = 1.73 \times 10^3 \text{ mm}^4$$

$$I_{yy} = 2.59 \times 10^3 \text{ mm}^4$$

A.P. = 208 mm

P.P. = - mm

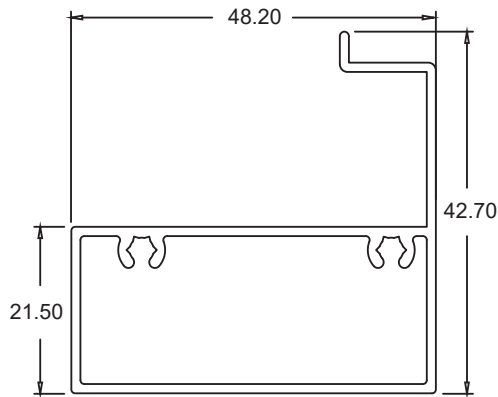
**TJ734**

Flyscreen Adaptor

$$I_{xx} = 38.363 \times 10^3 \text{ mm}^4$$

$$I_{yy} = 70.017 \times 10^3 \text{ mm}^4$$

A.P. = 211 mm

P.P. = 211 mm

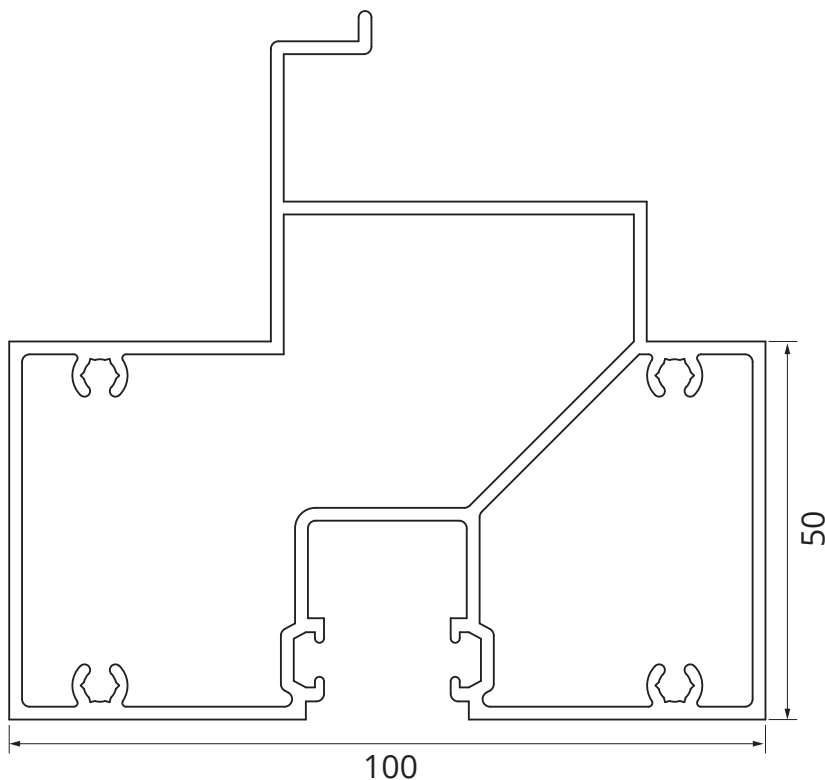
**CSG727**

35mm Awning Transom

$$I_{xx} = 598.1 \times 10^3 \text{ mm}^4$$

$$I_{yy} = 872.2 \times 10^3 \text{ mm}^4$$

A.P. = 491 mm

P.P. = 388 mm

## Mainframe Profiles

Scale 1:1

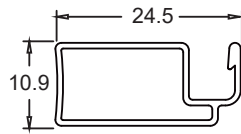
**HFF180**

11mm Flyframe

$$I_{xx} = 0.956 \times 10^3 \text{ mm}^4$$

$$I_{yy} = 3.758 \times 10^3 \text{ mm}^4$$

A.P. = 85 mm

P.P. = 100 mm

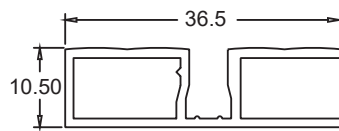
**WF001**

Standard Security Screen

$$I_{xx} = - \times 10^3 \text{ mm}^4$$

$$I_{yy} = - \times 10^3 \text{ mm}^4$$

A.P. = 140 mm

P.P. = 100 mm

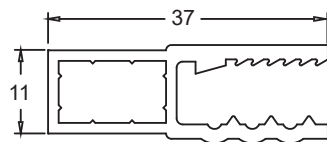
**AU01002**

Screenguard Security Screen

$$I_{xx} = 3.752 \times 10^3 \text{ mm}^4$$

$$I_{yy} = 19.202 \times 10^3 \text{ mm}^4$$

A.P. = 152 mm

P.P. = 100 mm

35MM AWNING

CityView 100mm Adaptors

KW040 76mm to 100mm Box Joiner

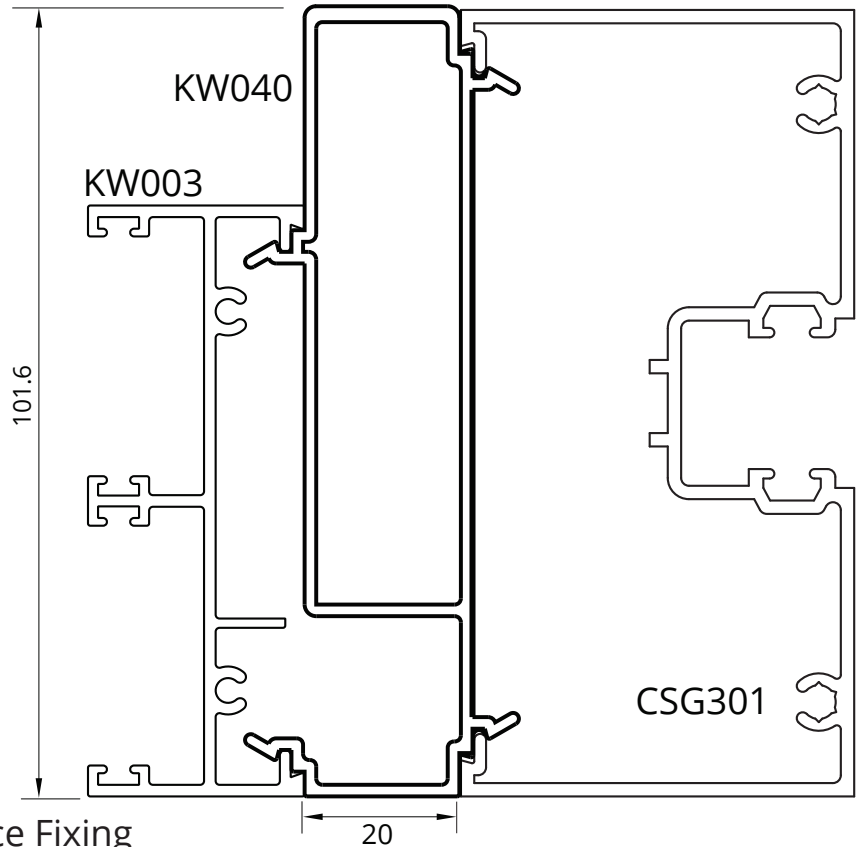

RWM053 Concealed Face Fixing

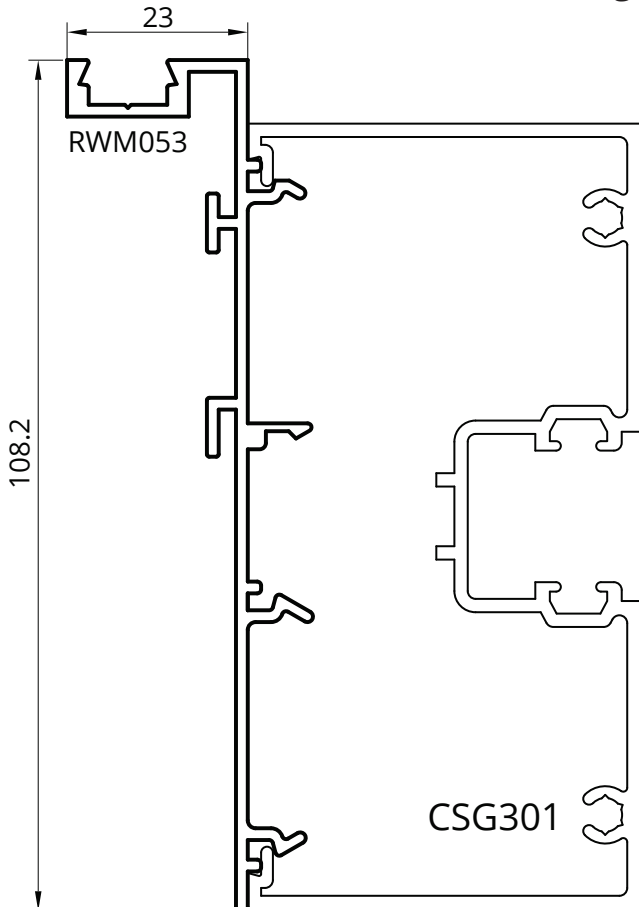

KW039 76mm to 100mm Flat Joiner

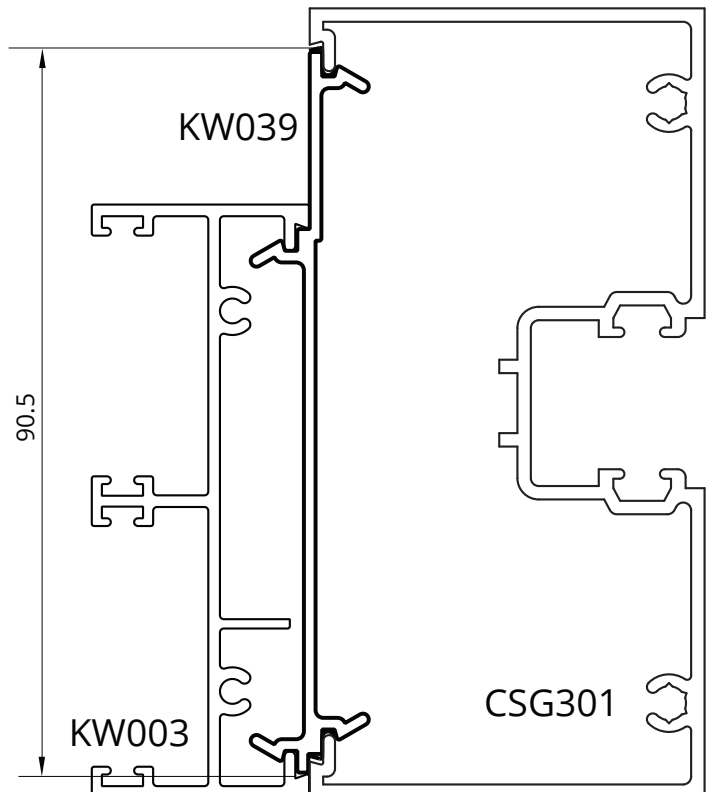

KWSD068 Inline Reveal Option

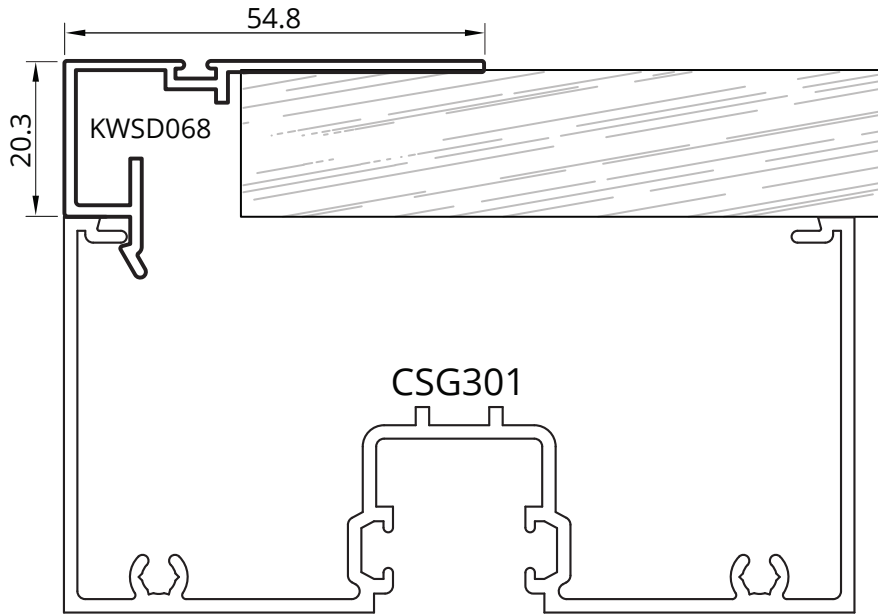

KW042 100mm Fixing Plate

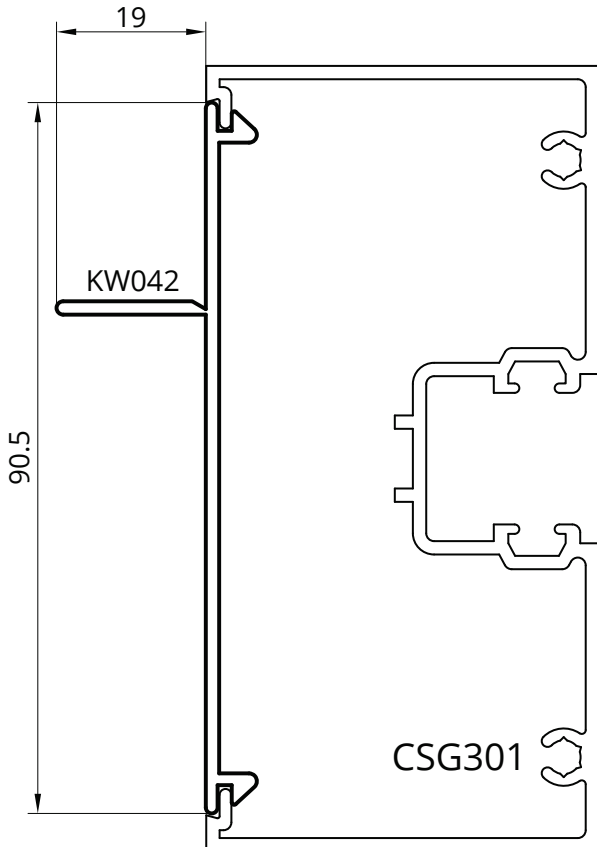

KW048 Concealed Face Fixing

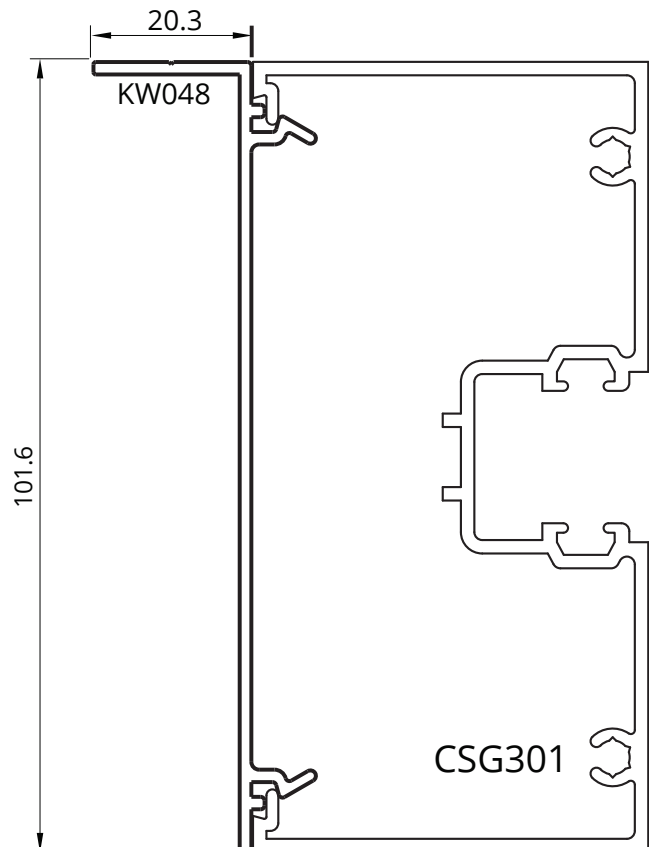

TJ345 100mm Fixing Plate

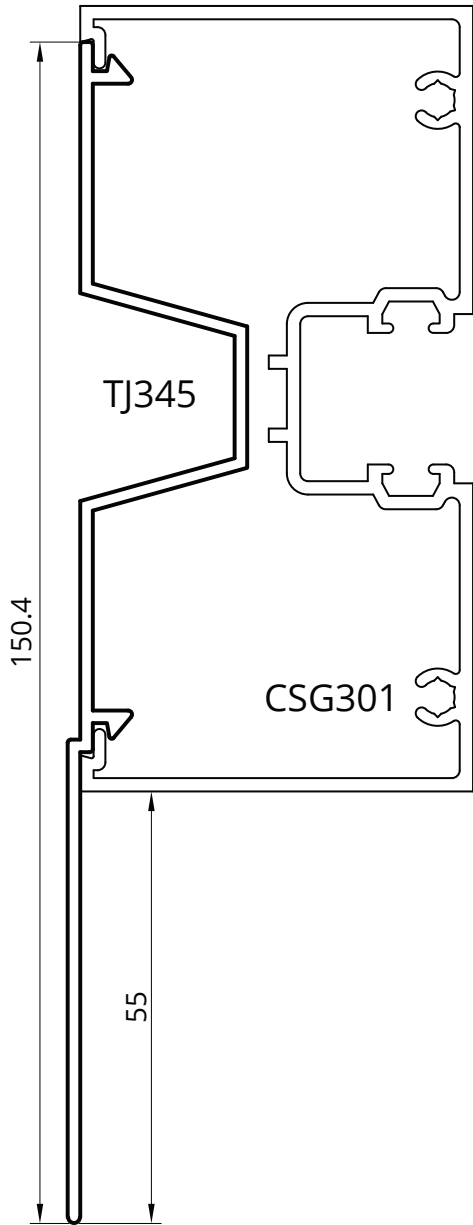

KW042 100mm Fixing Plate

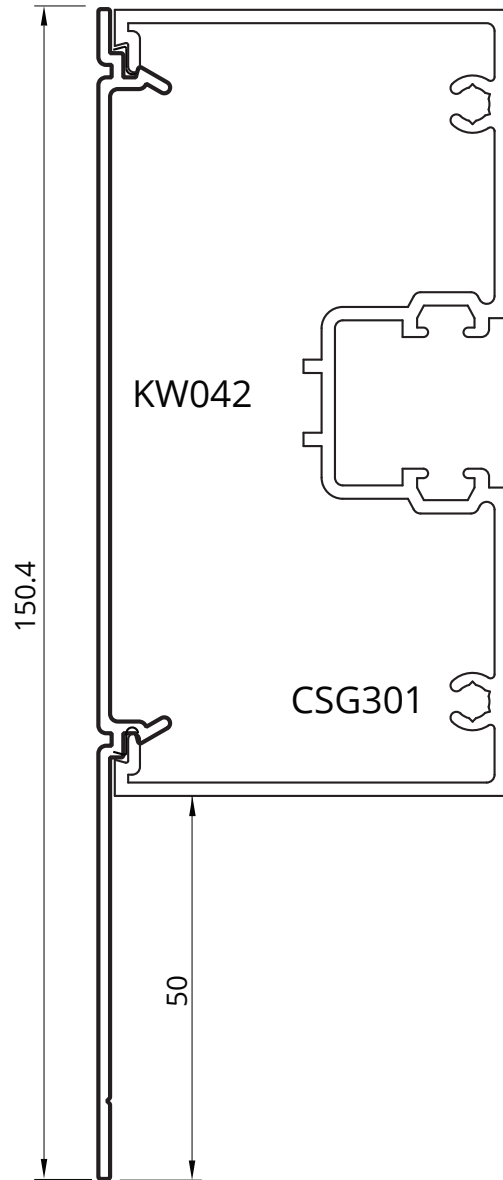









## Small Parts

	Code	Description	U.O.M	BOX QTY.
	1080**	Whitco Mk8 Non-Locking Chainwinder - Standard **Specify finish: Black: 1080-BL, Primrose: 1080-PR, White: 1080-WH	Each	10
	1082	Whitco Mk8 Non-Locking Chainwinder - Black Non Corrosive	Each	10
	1090	Whitco Mk8 Locking Chainwinder - K/N 32381 - Standard **Specify finish: Black: 1090-BL, Primrose: 1090-PR, White: 1090-WH, Silver: 1090-SCA	Each	10
	1092	Locking Chainwinder - Black K/N 32381 - Non-corrosive **Specify finish: Black: 1092-BL, Primrose: 1092-PR, White: 1092-WH, Silver: 1092-SCA	Each	NA
	1227-BL	Locking Chainwinder - Black stainless steel chain - Keyed 92608	Each	
	1227-WH	Locking Chainwinder - Black stainless steel chain - Keyed 92608	Each	
	1229-BL	Locking Twin Chainwinder - Black stainless steel chain	Each	
	1229-WH	Locking Twin Chainwinder - White stainless steel chain	Each	
	1098-SQ	Chain Length Restriction Plug - Works with 1080, 1082, 1090, 1092 10 Per bag	Bag	10
	1099	Chainwinder Bracket - Black - Height = 20mm	Each	20
	1240	Awning Handle - Wedgeless - Right Hand - Black Non-Locking	Each	10

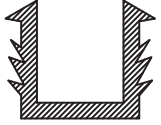
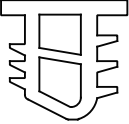
## Small Parts

	Code	Description	U.O.M	BOX QTY.
	1241	Awning Handle - Wedgeless - Left Hand - Black Non-Locking	Each	10
	1242	Awning Handle - Wedgeless - Right Hand - Black Locking	Each	10
	1243	Awning Handle - Wedgeless - Left Hand - Black Locking	Each	10
	1450	Glazing Tape - D/Sided Black PVC - 1.6mm x 12mm - 50m Roll	Roll	20
	1451	Glazing Tape - D/Sided Black PVC - 3.2mm x 12mm - 25m Roll	Roll	20
	1452	Glazing Tape - D/Sided Black PVC - 4.8mm x 12mm - 15.2m Roll	Roll	20
	1453A	Glazing Tape - D/Sided Black PVC - 6.4mm x 12mm - 15.2m Roll	Roll	18
	1600	Bulb Seal PVC - 250m Roll	Roll	1
	1601	Bulb Seal Co-Extruded - 100m Roll	Roll	N/A
	2641	Qlon - Push in - 400m Roll Suits: TJ741	Roll	N/A
	1615	Glazing Wedge PVC - 200m Roll	Roll	1

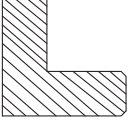
Small Parts

	Code	Description	U.O.M	BOX QTY.
	1620	Glazing Wedge PVC - 200m Roll	Roll	1
	1630	Glazing Wedge PVC - 200m Roll	Roll	1
	1605	Glazing Channel to Suit 6mm Awning Window - 200m Roll Suits: TJ738/739	Roll	N/A
	1931	Glazing Wedge - 100m Roll	Roll	1
	1623	Glazing Wedge - 100m Roll	Roll	1
	1933	Glazing Wedge - 125m Roll	Roll	1
	1851	35mm Corner Stake for Awning Sash Suits: TJ722/723/724/725/726/729	Each	100
	1854	35mm Corner Stake for Sash - Suitable for Crimping Suits: TJ722/723	Each	100
	1864	50mm Sash Corner Plate	Bag	100
	BDX-CV-CS-G/H/AW	CSG Frame / Hinged / Hook Awning Hydraulic Tool		

## Electric Chainwinder Box: Doric Ventus

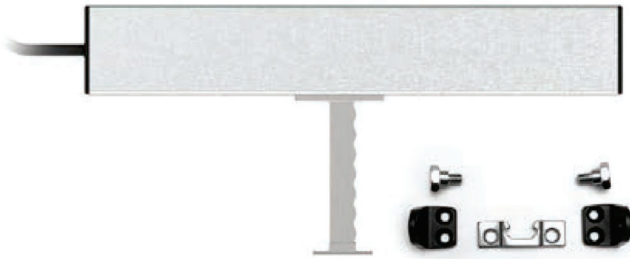

SCE100S	
<b>Voltage</b>	24V DC
<b>Push/Pull Force</b>	250N
<b>Chain Projection</b>	100mm
<b>Max Window Height</b>	1500mm
<b>Max Window Width</b>	350mm - 1200mm
<b>Chain</b>	304 Stainless Steel
<b>Doric Code</b>	9052637 - SCE100S



SCE300S	
<b>Voltage</b>	24V DC
<b>Push/Pull Force</b>	250N
<b>Chain Projection</b>	300mm
<b>Max Window Height</b>	1500mm
<b>Max Window Width</b>	350mm - 1200mm
<b>Chain</b>	304 Stainless Steel
<b>Doric Code</b>	9052809 - SCE300S

SIZE CHART					
Configuration	Max Height	Max Width	Max m <sup>2</sup>	Max Weight	Force of Motor
<b>SCE100s</b>					
Single	1500mm	1200mm	1.8	25kg	250N
Two Units (Synchronised)	1200mm	2400mm	2.88	50kg	Combined 500N
<b>SCE300s</b>					
Single	1500mm	1200mm	1.8	25kg	250N
Two Units (Synchronised)	1200mm	2400mm	2.88	50kg	Combined 500N

For a comprehensive list of required and optional hardware for this system, please contact your Darley representative.

Electric Chainwinder Box: FSA Fentec



ECO 230V	
<b>Voltage</b>	110/240V AC
<b>Push/Pull Force</b>	250N
<b>Chain Projection</b>	125, 240, 360mm
<b>Min Window Height (Determined by Chain Projection)</b>	150, 250, 350mm
<b>FSA Code</b>	F-ECOSY-C

ECO 24V	
<b>Voltage</b>	24V DC
<b>Push/Pull Force</b>	250N
<b>Chain Projection</b>	125, 240, 360mm
<b>Min Window Height (Determined by Chain Projection)</b>	150, 250, 350mm
<b>FSA Code</b>	F-ECOSY24-C

SIZE CHART			
Chain Projection	Min Height	Max Weight	Force of Motor
125mm	150mm	56kg	250N
240mm	250mm	48kg	250N
360mm	350mm	45kg	250N

For a comprehensive list of required and optional hardware for this system, please contact your Darley representative.

Performance Summary

Performance

PERFORMANCE							
System	Test Size	Panel Size	Ser	Water	Ult	Report	Glass
35mm Awning in 100mm CSG	1035x1140	935 x 935	0	300	2000	AZT0127.08	6-24
35mm Awning in 100mm One Piece Transom	2333x907	1633 x 907	1200	300	3000	AZT0489.20	6-24
35mm Awning in 100mm One Piece Transom	2333x907	1633 x 907	1200	500	3000	AZT0490.20	6-24
100mm Centre Glazed - Chainwinder	2545 x 2450	1110 x 1080	1200	300	3000	AZT0235.23	6-24
100mm Centre Glazed - Chainwinder + Cams	2545 x 2455	1110 x 1080	1500	300	3000	AZT0239.23	6-24

ACOUSTIC PERFORMANCE				
System	Rw	C : CTR	Report	Glass
CityView Awning	36	-1 ; -3	4858-1	10.38 Hush Clr Lam
CityView 35mm Awning	38	-1 ; -4	4858-2	10.52 Hush Lam

BAL FIRE RATING			
System	BAL	Report	Glass
CityView 35mm Awning	BAL-40	FRT210417	6mm Toughened

TESTED BY NEUTRAL THIRD PARTIES



warringtonfire

See Performance Section for more detail.  
 Taller maximums may be achievable via strength charts  
 Size limitations are governed by design intent, glass selection and local wind load and deflection requirements.

For further technical assistance and fabricator selection contact Darley Aluminium.  
 An Engineer should be consulted to ensure selected framing meets the requirements as set out in the relevant Australian Standards



## LABORATORY TEST RESULTS: CityView CSG 35mm Awning Window - stays

The following data was obtained from the results of the tests on the Darley Awning Window as performed in the Azuma Testing Laboratory (NATA Accredited).

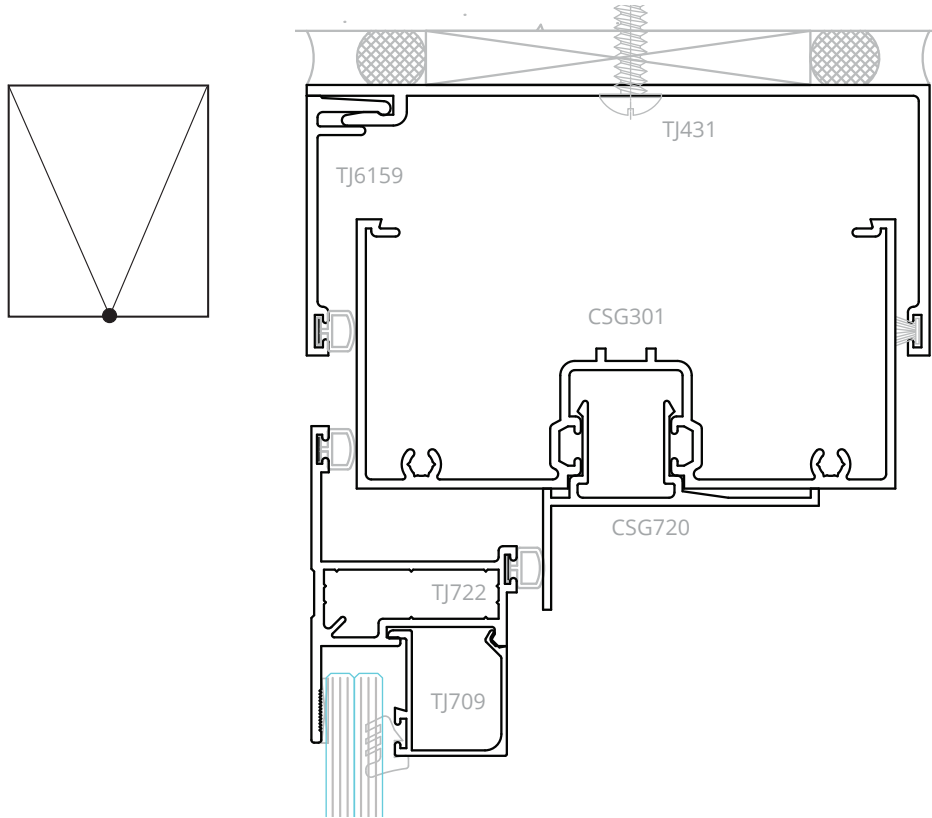

Performance

Test & Date	AZT0127.08, 25/08/2008
Test Size	1035mm H x 1140mm W
Hardware	Whitco Chainwinder, Stays 1211
Serviceability Load	0
Air Infiltration	+75 Pa = 0.00 L/s.m2 -75 Pa = 0.25 L/s.m2 +150 Pa = 0.00 L/s.m2 -150 Pa = 0.21 L/s.m2
Water Penetration	300 Pa
Ultimate Strength	+/- 2000 Pa

## LABORATORY TEST RESULTS: CityView 35mm One-Piece Transom Window - Hook

The following data was obtained from the results of the tests on the Darley Awning Window as performed in the Azuma Testing Laboratory (NATA Accredited).

Performance

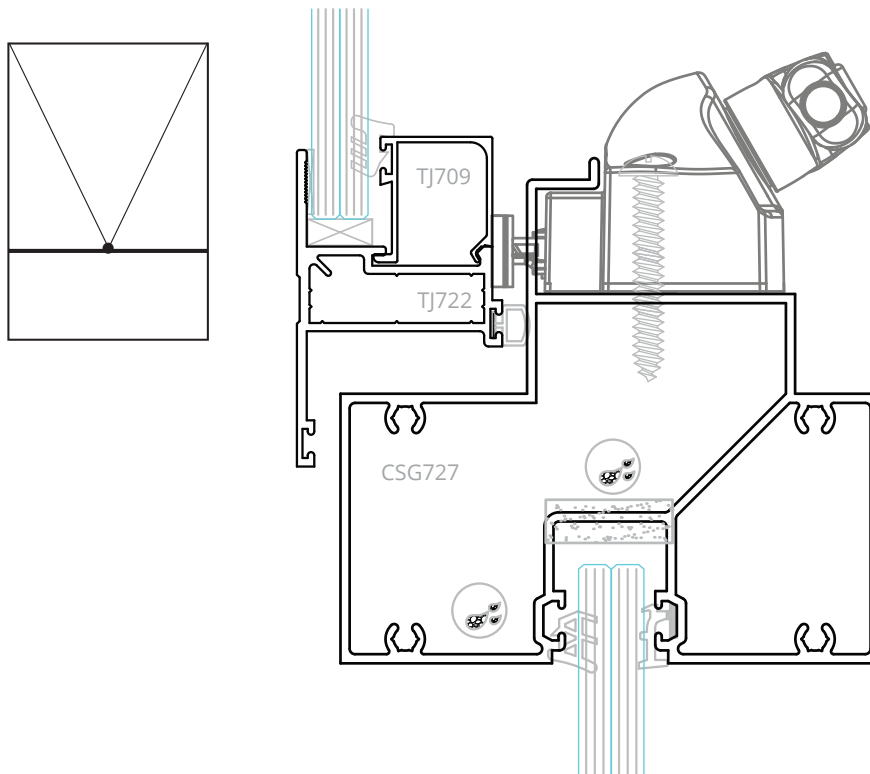

Test & Date	AZT0489.20, 16/11/2020
Test Size	2333mm H x 907mm W
Hardware	1227 Chainwinder, Hook Hinge
Serviceability Load	+/-1200
Air Infiltration	+75 Pa = 0.62 L/s.m2 -75 Pa = 0.80 L/s.m2
Water Penetration	300 Pa
Ultimate Strength	+/- 3000 Pa

## LABORATORY TEST RESULTS: CityView One-Piece Transom Window - Hook

The following data was obtained from the results of the tests on the Darley Awning Window as performed in the Azuma Testing Laboratory (NATA Accredited).

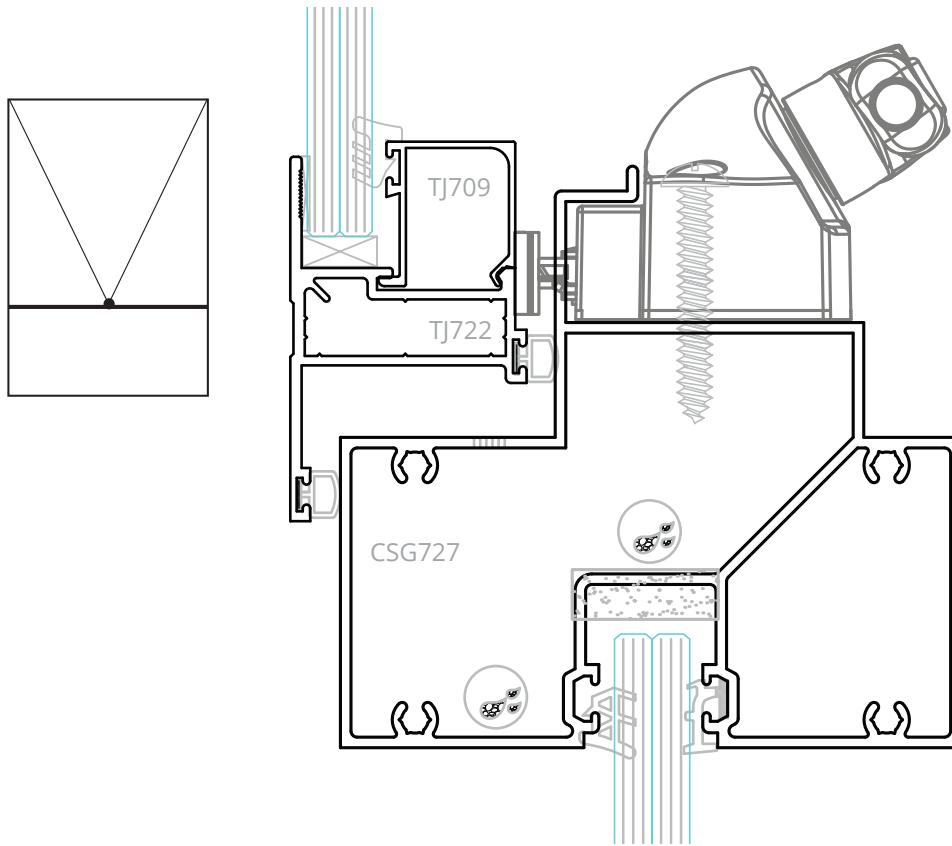

Performance

Test & Date	AZT0490.20, 16/11/2020
Test Size	2333mm H x 907mm W - SASH 1610mm H x 840mm W
Hardware	1227 Chainwinder, Hook Hinge
Serviceability Load	+/-1200
Air Infiltration	+75 Pa = 0.62 L/s.m2 -75 Pa = 0.80 L/s.m2 +150 Pa = 0.80 L/s.m2 -150 Pa = 0.80 L/s.m2
Water Penetration	500 Pa
Ultimate Strength	+/- 3000 Pa

## LABORATORY TEST RESULTS: CityView Window with Chainwinder - Hook

The following data was obtained from the results of the tests on the Darley Awning Window as performed in the Azuma Testing Laboratory (NATA Accredited).

Performance

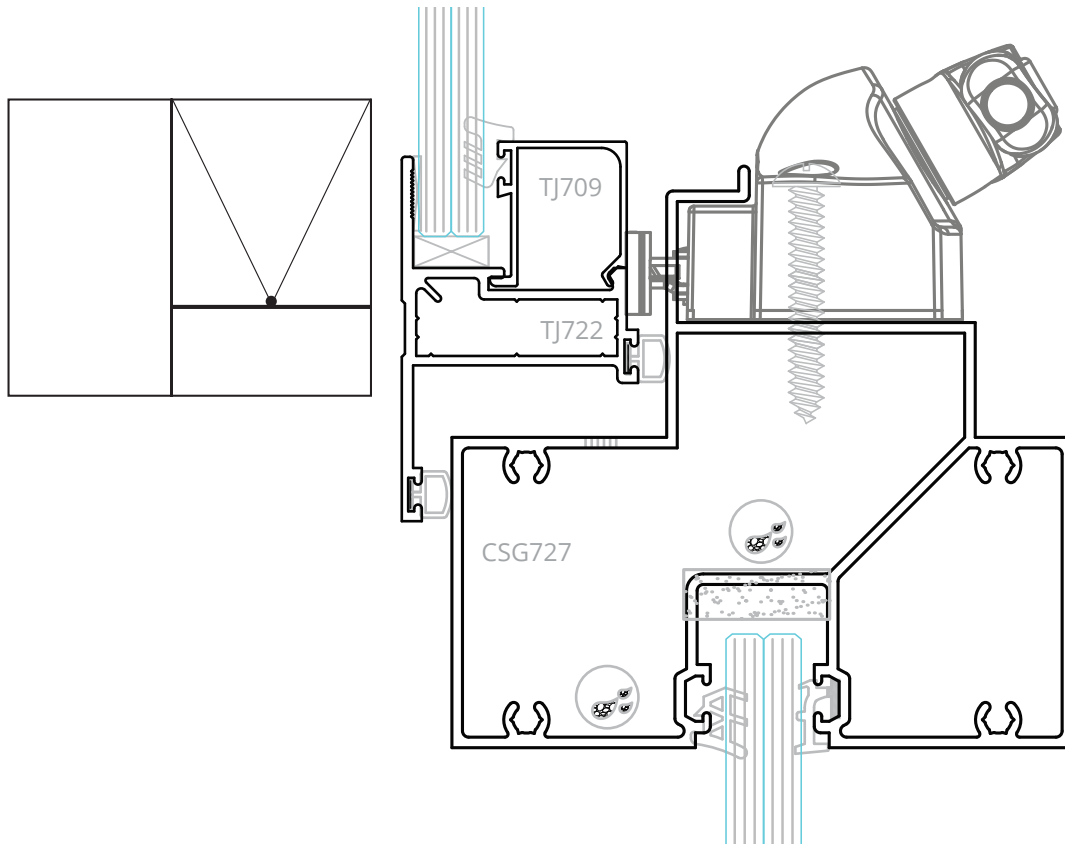

Test & Date	AZT0235.23, 30/06/2023
Test Size	2545mm H x 2450mm W, SASH 1200mm H x 1200mm W
Hardware	1227 Chainwinder
Serviceability	+/-1200
Air Infiltration	+75 Pa = 0.12 L/s.m2 -75 Pa = 0.14 L/s.m2
Water Penetration	300 Pa
Ultimate	+/- 3000 Pa

## LABORATORY TEST RESULTS: CityView Window with Chainwinder - Hook

The following data was obtained from the results of the tests on the Darley Awning Window as performed in the Azuma Testing Laboratory (NATA Accredited).

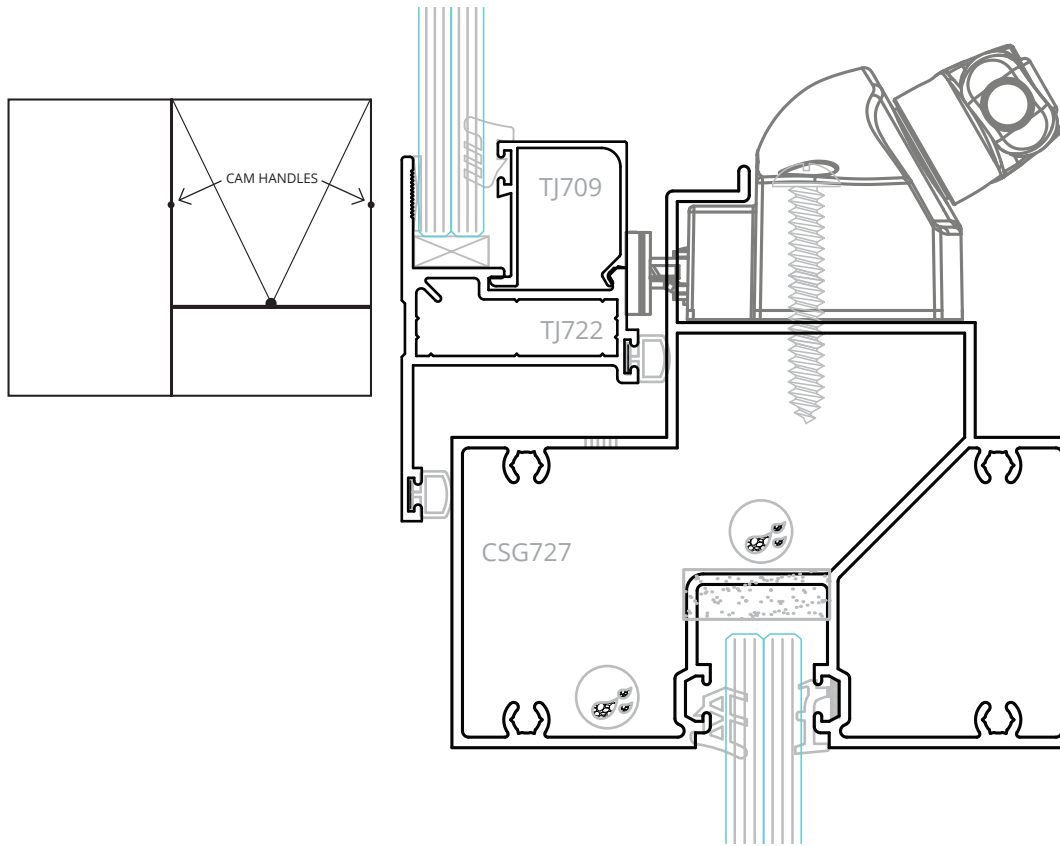

Performance

Test & Date	AZT0239.23, 30/06/2023
Test Size	2545mm H x 2455mm W, SASH 1200mm H x 1200mm W
Hardware	1227 Chainwinder, with Cam Handles
Serviceability	+/-1500
Air Infiltration	+75 Pa = 0.12 L/s.m2 -75 Pa = 0.14 L/s.m2
Water Penetration	300 Pa
Ultimate	+/- 3000 Pa

Acoustic Test Report

LABORATORY TEST RESULTS: CityView Awning Window

Test Report No. : 4858-1  
 Date: 17/01/2013  
 Glass Type: 10.38mm Clr Lam  
 Acoustic Rating: 36 Rw

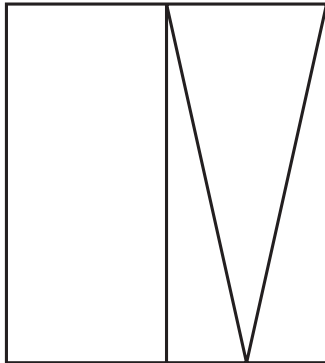

Frequency - Hz	Sound Reduction Index - dB	
	1/3 Octave	1/1 Octave
100	21.1	24.3
125	27.4	
160	28.1	
200	28.2	29.4
250	29.1	
315	31.6	
400	32.3	33.5
500	33.5	
630	35.1	
800	35.5	34.4
1000	33.9	
1250	34.0	
1600	34.3	36.2
2000	36.1	
2500	40.2	
3150	42.7	45.1
4000	46.3	
5000	48.5	
<b>R<sub>w</sub> (C;C<sub>tr</sub>)</b>	<b>36 ( -1 ; -3 )</b>	

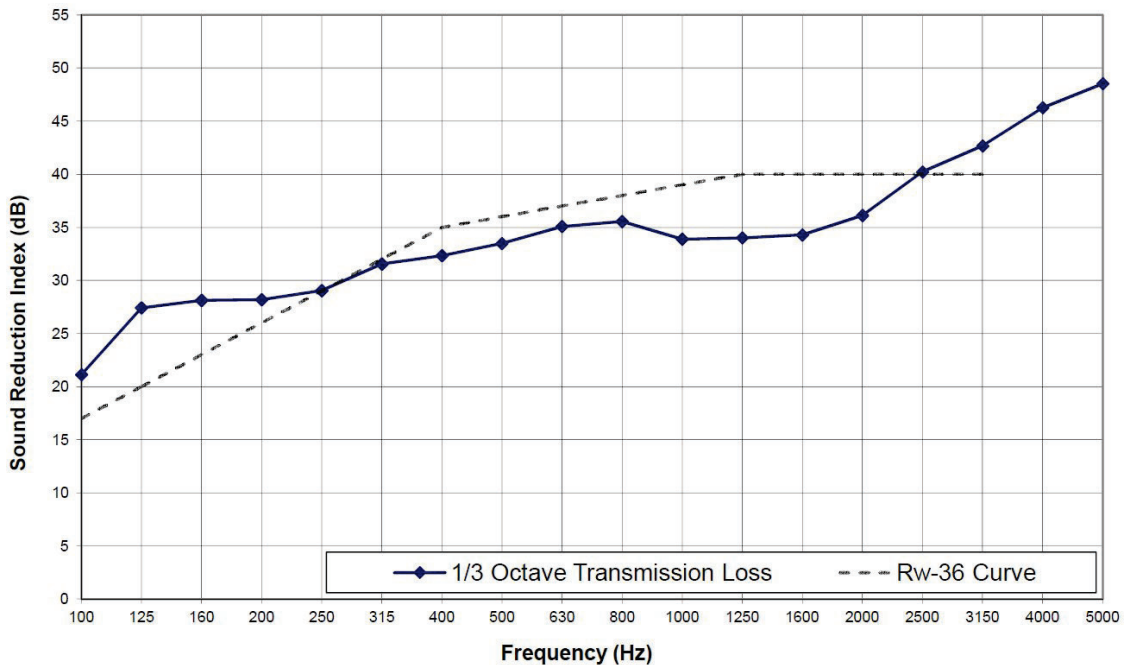

Acoustic

# Acoustic Test Report

## LABORATORY TEST RESULTS: CityView Awning Window

Tested Rw value of 38; see results below

Test Report No. : 4858-2  
 Date: 17/01/2013  
 Glass Type: 10.52mm Hush Lam  
 Acoustic Rating: 38 Rw

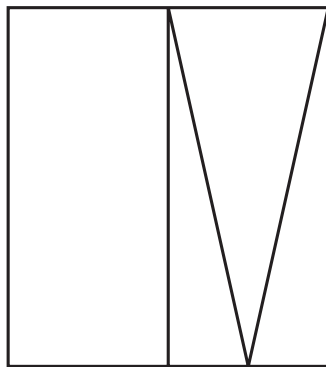

Frequency - Hz	Sound Reduction Index - dB	
	1/3 Octave	1/1 Octave
100	21.1	24.4
125	27.4	
160	28.5	
200	28.6	29.6
250	29.2	
315	31.8	
400	32.5	33.8
500	33.6	
630	36.2	
800	37.9	38.8
1000	39.0	
1250	39.9	
1600	39.6	40.0
2000	38.9	
2500	42.2	
3150	43.9	46.0
4000	46.7	
5000	48.6	
<b>R<sub>w</sub> (C;C<sub>tr</sub>)</b>	<b>38 ( -1 ; -4 )</b>	

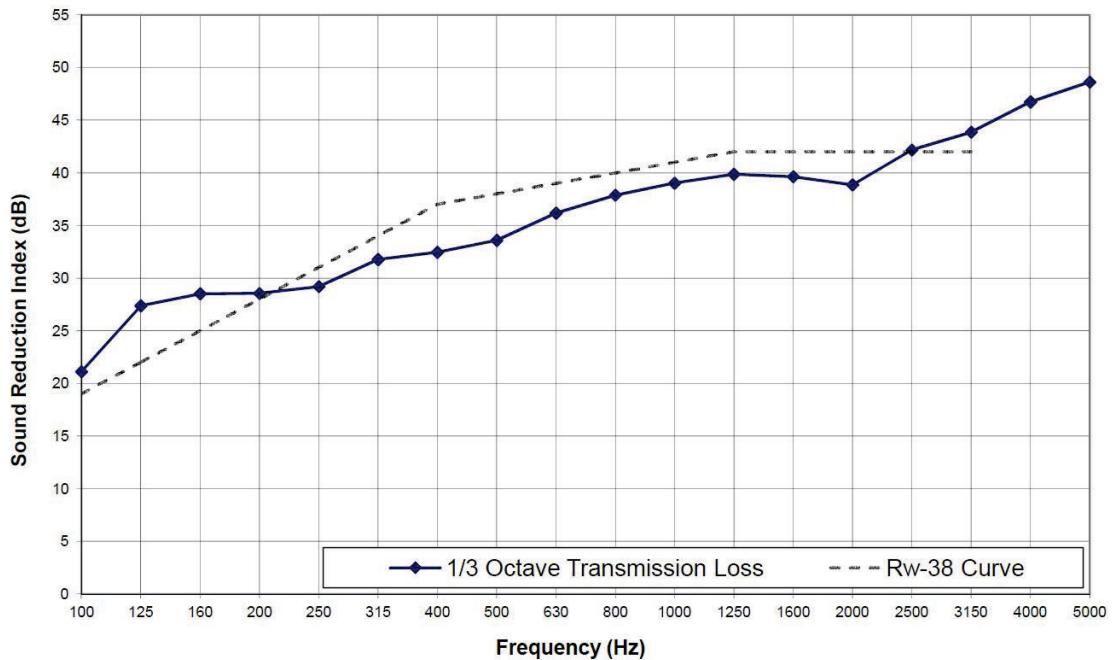

Acoustic

Acoustic Test Report

LABORATORY TEST RESULTS: CityView Awning Window

Test Report No. : 4858-2  
 Date: 17/01/2013  
 Glass Type: 10.52mm Hush Lam  
 Acoustic Rating: 38 Rw

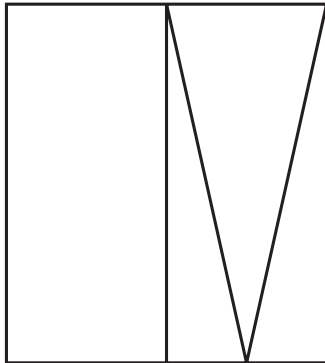

Frequency - Hz	Sound Reduction Index - dB	
	1/3 Octave	1/1 Octave
100	21.1	24.4
125	27.4	
160	28.5	
200	28.6	29.6
250	29.2	
315	31.8	
400	32.5	
500	33.6	33.8
630	36.2	
800	37.9	
1000	39.0	38.8
1250	39.9	
1600	39.6	
2000	38.9	40.0
2500	42.2	
3150	43.9	
4000	46.7	46.0
5000	48.6	
<b>R<sub>w</sub> (C;C<sub>tr</sub>)</b>	<b>38 ( -1 ; -4 )</b>	

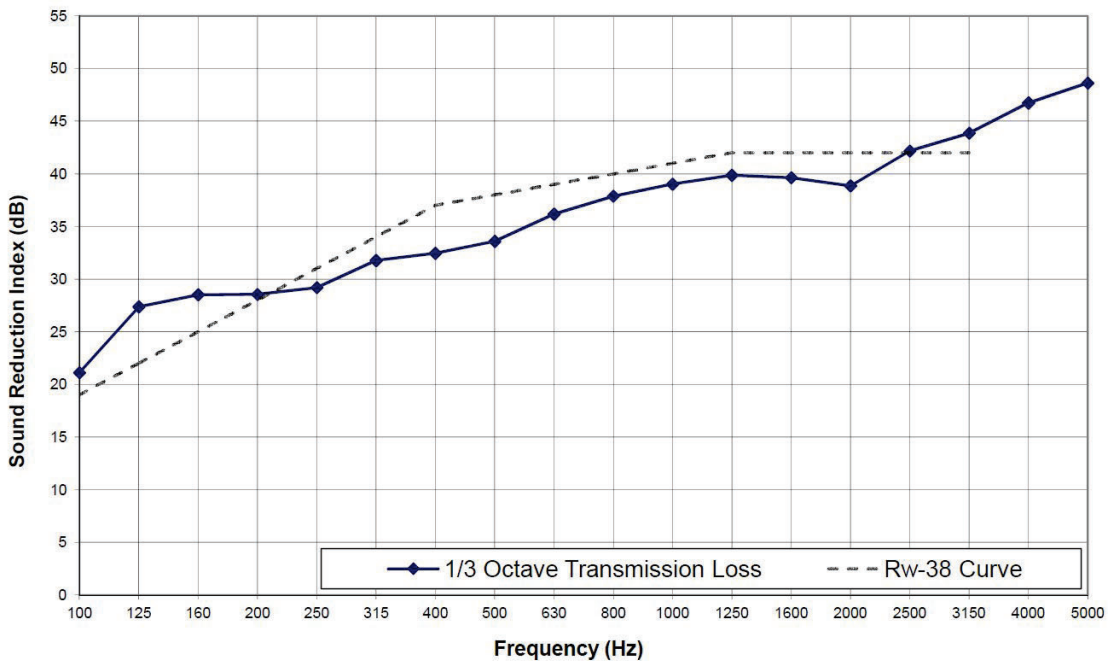

Acoustic

## BAL Compliance

### Bushfire attack levels achievable via test report no. FRT210417

**Test Standard:** Clauses 14 and 16 of AS 1530.8.1:2018

**Test Sponsor:** Darley Aluminium Trading Pty Ltd

**Product:** Darley CityView Combination Window System

**Bushfire Attack Level (BAL) Exposure:** 40 kW/m<sup>2</sup>

**Crib Class:** AA

**Job Number:** FRT210417

**Test Date:** 10 March 2022 **Revision:** R1.0

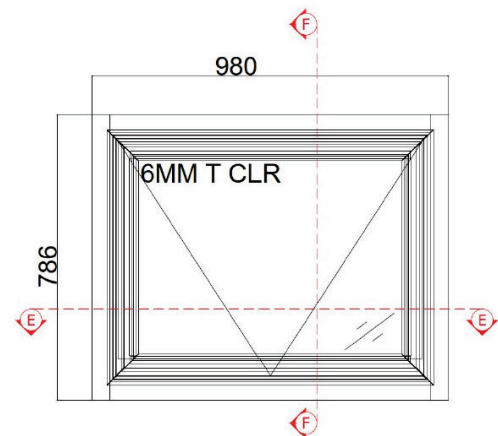

	BAL-12.5	BAL-19	BAL-29	BAL-40
<b>FRAME</b>	Low-level framing must be manufactured from either: <ul style="list-style-type: none"> <li>• <b>Metal</b>, or</li> <li>• Bushfire resistant timber or</li> <li>• Timber species with a density greater than 650 kg/m<sup>3</sup> or</li> <li>• Metal reinforced uPVC.</li> </ul>	Low-level framing must be manufactured from either: <ul style="list-style-type: none"> <li>• <b>Metal</b>, or</li> <li>• Bushfire resistant timber or</li> <li>• Timber species with a density greater than 650 kg/m<sup>3</sup> or</li> <li>• Metal reinforced uPVC.</li> </ul>	Low-level framing must be manufactured from either: <ul style="list-style-type: none"> <li>• <b>Metal</b>, or</li> <li>• Bushfire resistant timber or</li> <li>• Metal reinforced uPVC.</li> </ul>	All framing must be <b>metal</b> .
<b>GLAZING</b>	Low-level glazing must be Grade A safety glass with a minimum thickness of 4 mm.	Low-level glazing must be Grade A safety glass with a minimum thickness of 5 mm.  In all other locations where annealed glass is used, it must be protected by an external screen (see screen requirements).	All glazing must be toughened glass with a minimum thickness of 5 mm.  Low-level glazing must be protected by an external screen (see screen requirements).	All glazing must be toughened glass with a minimum thickness of 6 mm.  All glazing must be protected by an external screen (see screen requirements).
<b>SCREENS</b>	Openable portions of windows must be screened either internally or externally.  Mesh or perforated sheet with a maximum aperture of 2mm manufactured from either: <ul style="list-style-type: none"> <li>- <b>Corrosion resistant steel (Screenguard)</b>, or</li> <li>- Bronze, or</li> <li>- <b>Aluminium (Perfguard)</b>.</li> </ul> Supporting frame must be manufactured from either: <ul style="list-style-type: none"> <li>• Metal (including aluminium), or</li> <li>• Bushfire resistant timber or</li> <li>• Timber species with a density greater than 650 kg/m<sup>3</sup>.</li> </ul>	Openable portions of windows must be screened either internally or externally.  Mesh or perforated sheet with a maximum aperture of 2mm manufactured from either: <ul style="list-style-type: none"> <li>- <b>Corrosion resistant steel (Screenguard)</b>, or</li> <li>- Bronze, or</li> <li>- <b>Aluminium (Perfguard)</b>.</li> </ul> Supporting frame must be manufactured from either: <ul style="list-style-type: none"> <li>• Metal (including aluminium), or</li> <li>• Bushfire resistant timber or</li> <li>• Timber species with a density greater than 650 kg/m<sup>3</sup>.</li> </ul> Where annealed glass is used, it must be protected by an external screen.	Openable portions of windows must be screened either internally or externally.  Mesh or perforated sheet with a maximum aperture of 2mm manufactured from either: <ul style="list-style-type: none"> <li>- <b>Corrosion resistant steel (Screenguard)</b>, or</li> <li>- Bronze, or</li> <li>- <b>Aluminium (Perfguard)</b>.</li> </ul> Supporting frame must be manufactured from either: <ul style="list-style-type: none"> <li>• Metal (including aluminium), or</li> <li>• Bushfire resistant timber.</li> </ul> Low-level glazing must be protected by an external screen.  Screen assemblies must be attached using metal fixings.	Fixed and openable portions of windows must be screened either internally or externally.  Mesh or perforated sheet with a maximum aperture of 2 mm manufactured from either: <ul style="list-style-type: none"> <li>- <b>Corrosion resistant steel (Screenguard)</b>, or</li> <li>- Bronze.</li> </ul> Aluminium mesh or perforated sheet cannot be used.  Supporting frame must be manufactured from metal (including aluminium).  Screen assemblies must be attached using metal fixings.
<b>SEALS</b>	N/A	N/A	N/A	Seals must be manufactured from <b>silicone</b> or have a flammability index less than 5.
<b>HARDWARE</b>	N/A	N/A	Externally fitted hardware that supports the sash in its functions of opening and closing must be metal unless shielded by metal frame components.	Externally fitted hardware that supports the sash in its functions of opening and closing, must be metal.

BAL

Glass & Rubber Combinations

Glazing

CityView 35mm Awning				
Glass Thickness	Bead	Tape	Wedge or Bulb Seal	Pocket Size
6mm		1452	1620	13.55
8mm	TJ709	1451	1630 or 1601	
10mm		1450	1630	
12mm		1452	1615	24
		1453	1620	
16mm	TJ713	1451		
		1452	1630	
18mm		1450		
20mm		1453	1615	31
		1452		
22mm	TJ016	1453	1601	
24mm		1452	1620	
		1453	1601	

6mm to 12mm Glass

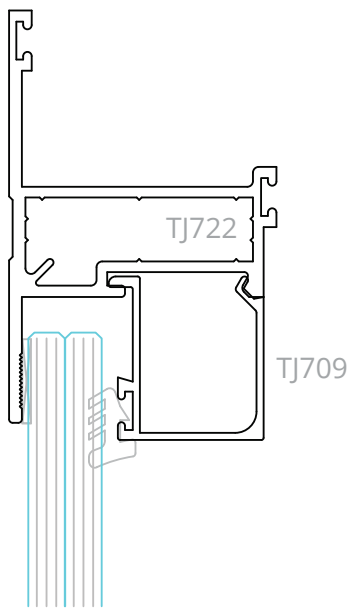

16mm to 24mm Glass

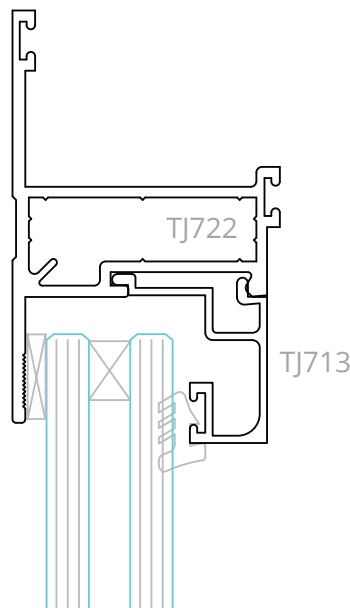

28mm to 30mm Glass

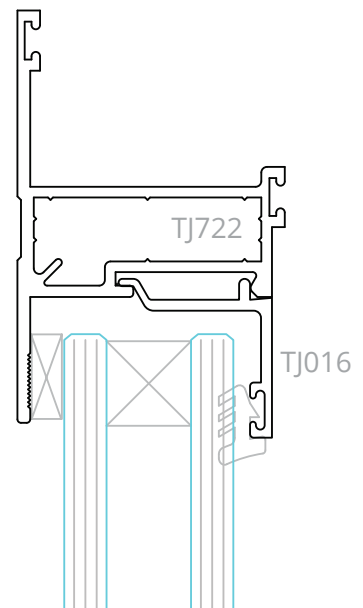

## Energy Ratings Definitions

All Darley products have been rated under the Australian Fenestration Ratings Council (AFRC) Energy Rating Scheme.

### Definitions

The following are terms used in describing the energy ratings of windows as defined by the Window Energy Rating Scheme (WERS). For further information go to [www.agwa.com.au/WERS](http://www.agwa.com.au/WERS)

### U-Value ( $U_w$ )

U-Value measures how well a product prevents heat from escaping. It is a measure of the rate of non solar heat loss or gain through a material or assembly. U-Value ratings generally fall between 2.0 - 10.0 W/m<sup>2</sup> for Australian products. The rate of heat is indicated in the terms of the U-Value of a window assembly which includes the effect of the frame, glass, seals and any spacers. The lower the U-value, the greater a window's resistance to heat flow and the better its insulating value. The U-Value for a window takes account for the various U-values for the components making up the window, so you may see these in technical literature:

$U_w$  is the value for the whole window and because of its importance is usually abbreviated to U.

$U_c$  is the value at the centre of glass.

$U_f$  is the value for the frame.

### Solar Heat Gain Coefficient ( $SHGC_w$ )

SHGC measures how well a product blocks heat caused by sunlight. The SHGC is a fraction of incident solar radiation admitted through a window, both directly transmitted, and absorbed and subsequently released inward. SHGC is expressed as a number between 0 and 1. The lower a window's SHGC, the less solar heat it transmits.

### Visible Transmittance ( $T_{vw}$ )

Visible transmittance measures how much light comes in through a product. It is an optical property that indicates the amount of visible light transmitted.  $T_{vw}$  is expressed as a number between 0 and 1. The higher the number, the more light is transmitted.

## Energy Ratings: Single Glazed

Window Id	Glass Supplier	Glass	Uw	SHGCw	TVw	Air Infiltr.	Glass Type
DAR-006-304	<UNKNOWN>	9.52mm SOL-XT Grey 32	5.598	0.238	0.188	0.25	Low-E
DAR-006-303	OCEANIA	10.38CPNtl	5.633	0.352	0.371	0.25	Low-E
DAR-006-302	OCEANIA	10.38CPClr	5.64	0.421	0.468	0.25	Low-E
DAR-006-005	OCEANIA	6.38CPGn	5.659	0.353	0.421	0.25	Low-E
DAR-006-006	OCEANIA	6.38CPGy	5.662	0.348	0.231	0.25	Low-E
DAR-006-004	OCEANIA	6.38CPNtl	5.674	0.358	0.349	0.25	Low-E
DAR-006-023	SOLOS	SOLOS 6.38KSL Clr	5.707	0.453	0.487	0.25	Low-E
DAR-006-022	SOLOS	SOLOS 6.38KSL Gn	5.708	0.351	0.422	0.25	Low-E
DAR-006-020	SOLOS	SOLOS 6.38KSL Gy	5.71	0.346	0.231	0.25	Low-E
DAR-006-007	OCEANIA	6.38CPClr	5.711	0.455	0.487	0.25	Low-E
DAR-006-021	SOLOS	SOLOS 6.38KSL Ntl	5.722	0.356	0.349	0.25	Low-E
DAR-006-019	<UNKNOWN>	6i89	5.731	0.478	0.521	0.25	Low-E
DAR-006-307	OCEANIA	6SolTNtl	5.74	0.367	0.376	0.25	Low-E
DAR-006-011	OCEANIA	6EVClr	5.829	0.424	0.404	0.25	Low-E
DAR-006-016	OCEANIA	6EVBG	5.829	0.323	0.335	0.25	Low-E
DAR-006-010	OCEANIA	6EVGy	5.829	0.299	0.19	0.25	Low-E
DAR-006-017	OCEANIA	6EVAB	5.829	0.271	0.23	0.25	Low-E
DAR-006-014	OCEANIA	6EVBz	5.83	0.323	0.224	0.25	Low-E
DAR-006-018	OCEANIA	6EVSpGn	5.84	0.275	0.291	0.25	Low-E
DAR-006-003	<UNKNOWN>	6TS21	6.31	0.234	0.121	0.25	Low-E
DAR-006-009	<UNKNOWN>	6AzTS21	6.36	0.224	0.092	0.25	Low-E
DAR-006-300	OCEANIA	12.38ClrLam	6.597	0.48	0.505	0.25	Clear
DAR-006-301	OCEANIA	10.38ClrLam	6.65	0.484	0.509	0.25	Clear
DAR-006-305	GENERIC	10Clr	6.672	0.489	0.507	0.25	Clear
DAR-006-306	OCEANIA	10Gy	6.672	0.331	0.147	0.25	Clear
DAR-006-001	GENERIC	6Clr	6.757	0.531	0.524	0.25	Clear
DAR-006-002	OCEANIA	6Gy	6.757	0.39	0.26	0.25	Toned
DAR-006-008	GENERIC	6.38ClrLam	6.763	0.512	0.519	0.25	Clear
DAR-006-013	OCEANIA	6AB	6.804	0.358	0.312	0.25	Clear
DAR-006-015	OCEANIA	6SpGn	6.804	0.362	0.395	0.25	Toned
DAR-006-012	OCEANIA	6SpGy	6.804	0.262	0.051	0.25	Toned

**KEY**

Gy = Grey, Ntl = Neutral, Gn = Green, Clr = Clear, B = Blue, Bz = Bronze, Lam = Laminate, ComPls = Comfort Plus, SolT - SolTech, Sp = Super, ET = Energy Tech, EVan = Evantage, AZT = Solar Cool Azuria, Sngy = Sunergy.

**NOTES**

- Percentage improvement figures are compared with using base-case Generic Window 1 (3mm clear in standard aluminium frame)
- A negative percentage improvement figure indicates performance worse than the base-case window
- A positive percentage improvement figure indicates performance better than the base-case window
- Maximum air infiltration is 5.0 L/s.m<sup>2</sup> at a positive pressure difference of 75Pa as measured according to AS 2047
- Static performance (U, SHFC, Tw, Tdw) Calculated using Window 5.2 and Therm 5.2 software (LBNL), 2000-2003
- Annual energy performance (stars and % improvements) calculated using Nationwide House Energy Rating Software (AccuRate)
- Results disclosed at National fenestration Rating Council (NFRC) regulations

## Energy Ratings: Double Glazed

Window Id	Glass Supplier	Glass	Uw	SHGCw	TVw	Air Infiltr.	Glass Type
DAR-016-360	VIRIDIAN	4LB#2-12Ar90%-4ClrEtech#4	3.956	0.36	0.439	0.25	Low-E
DAR-016-361	VIRIDIAN	4ClimaTech#2/12Ar90%/4ClrEtech#4	3.984	0.361	0.44	0.25	Low-E
DAR-016-334	AGG	AGG MAX Clr 8_12_8	3.995	0.203	0.381	0.25	Low-E
DAR-016-330	AGG	AGG ADVANCE Clr 8_12_8	4.01	0.244	0.409	0.25	Low-E
DAR-016-337	AGG	AGG MAX Clr lam 6/12/6.3	4.013	0.205	0.397	0.25	Low-E
DAR-016-302	<UNKNOWN>	6CoolRay70/12Ar/6Clr	4.018	0.239	0.41	0.25	Clear
DAR-016-304	<UNKNOWN>	6Gy/12Ar/6CoolRay70	4.018	0.188	0.193	0.25	Clear
DAR-016-324	AGG	AGG PLUS Clr 8/12/8	4.027	0.358	0.453	0.25	Low-E
DAR-016-332	AGG	AGG ADVANCE Clr lam 6/12/6.38	4.029	0.248	0.427	0.25	Low-E
DAR-016-333	AGG	AGG MAX Clr 6/12/6	4.029	0.205	0.392	0.25	Low-E
DAR-016-335	AGG	AGG MAX LI 6/12/6	4.029	0.206	0.405	0.25	Low-E
DAR-016-336	AGG	AGG MAX Gy 6/12/6	4.029	0.171	0.196	0.25	Low-E
DAR-016-023	<UNKNOWN>	SOLOS OE Acu Sil 6.5/12Ar/6	4.034	0.37	0.467	0.25	Low-E
DAR-016-024	<UNKNOWN>	SOLOS OE Prv WTrans PTek 6.38/12Ar/6	4.038	0.305	0.353	0.25	Low-E
DAR-016-029	<UNKNOWN>	4LoE366/16Ar/4Clr	4.039	0.203	0.383	0.25	Low-E
DAR-016-315	AGG	AGG MAX Clr 6/12/4	4.039	0.205	0.401	0.25	Low-E
DAR-016-344	VIRIDIAN	6P-Tech PH08#2-12Ar90%-6Clr	4.04	0.239	0.408	0.25	Low-E
DAR-016-343	VIRIDIAN	6P-Tech PH20#2-12Ar90%-6Clr	4.041	0.155	0.275	0.25	Low-E
DAR-016-341	VIRIDIAN	6P-Tech PH30#2-12Ar90%-6Clr	4.043	0.218	0.408	0.25	Low-E
DAR-016-329	AGG	AGG ADVANCE Clr 6/12/6	4.045	0.248	0.421	0.25	Low-E
DAR-016-331	AGG	AGG ADVANCE Gy 6_12_6	4.045	0.199	0.211	0.25	Low-E
DAR-016-342	VIRIDIAN	6P-Tech PH25#2-12Ar90%-6Clr	4.047	0.195	0.356	0.25	Low-E
DAR-016-025	<UNKNOWN>	SOLOS OE Clr 6/12Ar/6	4.049	0.389	0.472	0.25	Low-E
DAR-016-026	<UNKNOWN>	SOLOS OE Gy 6/12Ar/6	4.049	0.242	0.223	0.25	Low-E
DAR-016-328	AGG	AGG PLUS Clr lam 6.38/12/6	4.05	0.38	0.473	0.25	Low-E
DAR-016-314	AGG	AGG ADVANCE Clr 6/12/4	4.055	0.248	0.431	0.25	Low-E
DAR-016-306	VIRIDIAN	LB Clr 6/12/6	4.056	0.369	0.468	0.25	Low-E
DAR-016-028	<UNKNOWN>	4Clr/16Ar/4OptiTherm	4.058	0.403	0.477	0.25	Low-E
DAR-016-327	AGG	AGG PLUS Clr lam 6.38/12/4	4.062	0.382	0.477	0.25	Low-E
DAR-016-323	AGG	AGG PLUS Clr 6/12/6	4.063	0.381	0.467	0.25	Low-E
DAR-016-326	AGG	AGG PLUS Gy 6/12/6	4.063	0.252	0.234	0.25	Low-E
DAR-016-033	G JAMES	4Clr/12Ar/4LumaTherm	4.068	0.379	0.482	0.25	Low-E
DAR-016-034	G JAMES	4LumaTherm/12Ar/4Clr	4.068	0.374	0.482	0.25	Low-E
DAR-016-035	G JAMES	4Gy/12Ar/4LumaTherm	4.068	0.277	0.3	0.25	Low-E
DAR-016-340	AGG	AGG PLUS Clr 5/12/5	4.078	0.384	0.47	0.25	Low-E
DAR-016-349	VIRIDIAN	6LtGry-12Ar90%-6LB#3	4.08	0.287	0.322	0.25	Low-E
DAR-016-350	VIRIDIAN	6Gry-12Ar90%-6LB#3	4.08	0.237	0.219	0.25	Low-E
DAR-016-031	G JAMES	6.38ClrLam/10Ar/4LumaTherm	4.087	0.354	0.472	0.25	Low-E

**KEY**

Gy = Grey, Ntl = Neutral, Gn = Green, Clr = Clear, B = Blue, Bz = Bronze, Lam = Laminate, ComPls = Comfort Plus, SolT - SolTech, Sp = Super, ET = Energy Tech, EVan = Everage, AZT = Solar Cool Azuria, Sngy = Sunergy.

**NOTES**

- Percentage improvement figures are compared with using base-case Generic Window 1 (3mm clear in standard aluminium frame)
- A negative percentage improvement figure indicates performance worse than the base-case window
- A positive percentage improvement figure indicates performance better than the base-case window
- Maximum air infiltration is 5.0 L/s.m2 at a positive pressure difference of 75Pa as measured according to AS 2047
- Static performance (U, SHFC, Tw, Tdw) Calculated using Window 5.2 and Therm 5.2 software (LBNL), 2000-2003
- Annual energy performance (stars and % improvements) calculated using Nationwide House Energy Rating Software (AccuRate)
- Results disclosed at National fenestration Rating Council (NFRC) regulations

Energy Ratings: Double Glazed

Glazing

Window Id	Glass Supplier	Glass	Uw	SHGCw	TVw	Air Infiltr.	Glass Type
DAR-016-032	G JAMES	6.38LtGyLam/10Ar/4LumaTherm	4.087	0.289	0.332	0.25	Low-E
DAR-016-030	G JAMES	6.38GyLam/10Ar/4LumaTherm	4.087	0.247	0.238	0.25	Low-E
DAR-016-322	AGG	AGG PLUS Clr 4/12/4	4.092	0.405	0.482	0.25	Low-E
DAR-016-325	AGG	AGG PLUS Gy 4/12/4	4.092	0.298	0.3	0.25	Low-E
DAR-016-353	VIRIDIAN	5Clr-12Ar90-5LB 3	4.095	0.38	0.467	0.25	Low-E
DAR-016-354	VIRIDIAN	5Gy/12Ar90%/5LB#3	4.095	0.256	0.25	0.25	Low-E
DAR-016-359	VIRIDIAN	4Clr-12Ar90-4LB	4.107	0.4	0.478	0.25	Low-E
DAR-016-347	VIRIDIAN	6Clr-12Ar90%-6ClimaTech#3	4.107	0.387	0.474	0.25	Low-E
DAR-016-348	VIRIDIAN	6ClimaTech#2-12Ar90%-6Clr	4.107	0.381	0.474	0.25	Low-E
DAR-016-345	VIRIDIAN	6LtGrey-12Ar90%-6CimaTech#3	4.107	0.295	0.329	0.25	Low-E
DAR-016-357	VIRIDIAN	4Gry-12Ar90%-4LB#3	4.107	0.286	0.294	0.25	Low-E
DAR-016-346	VIRIDIAN	6Grey/12Ar90/6CimaTech	4.107	0.244	0.223	0.25	Low-E
DAR-016-351	VIRIDIAN	5Clr/12Ar90/5ClimaTech 3	4.128	0.388	0.469	0.25	Low-E
DAR-016-352	VIRIDIAN	5Gy/12Ar90/5ClimaTech 3	4.128	0.263	0.25	0.25	Low-E
DAR-016-008	<UNKNOWN>	6GyLE/12Ar/6.38ClrLam	4.139	0.21	0.179	0.25	Low-E
DAR-016-356	VIRIDIAN	4Clr-12Ar90%-4ClimaTech#3	4.143	0.406	0.48	0.25	Low-E
DAR-016-358	VIRIDIAN	4ClimaTech#2/12Ar90%/4Clr	4.143	0.378	0.48	0.25	Low-E
DAR-016-355	VIRIDIAN	4Gry-12Ar90%-4CimaTech#3	4.143	0.291	0.295	0.25	Low-E
DAR-016-318	AGG	AGG PRIME Clr 8/12/8	4.163	0.348	0.387	0.25	Low-E
DAR-016-300	OCEANIA	6Clr/12Ar/6ET	4.177	0.445	0.436	0.25	Low-E
DAR-016-305	<UNKNOWN>	6.38CPNtl/12/6Clr	4.177	0.299	0.314	0.25	Low-E
DAR-016-301	OCEANIA	6SolTNtl/12Ar/6Clr	4.178	0.445	0.436	0.25	Low-E
DAR-016-303	OCEANIA	6ETGy/12Ar/6Clr	4.199	0.272	0.213	0.25	Low-E
DAR-016-317	AGG	AGG PRIME Clr 6/12/6	4.202	0.361	0.399	0.25	Low-E
DAR-016-320	AGG	AGG PRIME Gy 6/12/6	4.202	0.279	0.2	0.25	Low-E
DAR-016-321	AGG	AGG PRIME Clr lam 6/12/6.38	4.207	0.37	0.408	0.25	Low-E
DAR-016-362	AGG	AGG PRIME Clr lam 4/12/6.38	4.207	0.37	0.408	0.25	Low-E
DAR-016-338	AGG	AGG PRIME Clr 5/12/5	4.219	0.366	0.402	0.25	Low-E
DAR-016-319	AGG	AGG PRIME Gy 4/12/4	4.235	0.33	0.256	0.25	Low-E
DAR-016-316	AGG	AGG PRIME Clr 4/12/4	4.236	0.373	0.412	0.25	Low-E
DAR-016-007	<UNKNOWN>	6TS21/12/6EA	4.301	0.138	0.089	0.25	Low-E
DAR-016-002	G JAMES	6LE/12/6Clr	4.315	0.412	0.436	0.25	Low-E
DAR-016-005	<UNKNOWN>	6InsEG/12/6EA	4.315	0.249	0.323	0.25	Low-E
DAR-016-003	<UNKNOWN>	6InsClr/12/6EA	4.316	0.44	0.435	0.25	Low-E
DAR-016-011	<UNKNOWN>	6TS21/12/6EVClr	4.35	0.151	0.091	0.25	Low-E
DAR-016-009	OCEANIA	6Clr/12/6EVClr	4.372	0.402	0.367	0.25	Low-E
DAR-016-010	<UNKNOWN>	6EVClr/12/6Clr	4.372	0.376	0.367	0.25	Low-E
DAR-016-012	<UNKNOWN>	6SpGn/12/6EVClr	4.372	0.234	0.275	0.25	Low-E

**KEY**

Gy = Grey, Ntl = Neutral, Gn = Green, Clr = Clear, B = Blue, Bz = Bronze, Lam = Laminate, ComPls = Comfort Plus, SolT - SolTech, Sp = Super, ET = Energy Tech, EVan = Eantage, AZT = Solar Cool Azuria, Sngy = Sunergy.

**NOTES**

- Percentage improvement figures are compared with using base-case Generic Window 1 (3mm clear in standard aluminium frame)
- A negative percentage improvement figure indicates performance worse than the base-case window
- A positive percentage improvement figure indicates performance better than the base-case window
- Maximum air infiltration is 5.0 L/s.m2 at a positive pressure difference of 75Pa as measured according to AS 2047
- Static performance (U, SHFC, Tw, Tdw) Calculated using Window 5.2 and Therm 5.2 software (LBNL), 2000-2003
- Annual energy performance (stars and % improvements) calculated using Nationwide House Energy Rating Software (AccuRate)
- Results disclosed at National fenestration Rating Council (NFRC) regulations

## Energy Ratings: Double Glazed

Window Id	Glass Supplier	Glass	Uw	SHGCw	TVw	Air Infiltr.	Glass Type
DAR-016-017	<UNKNOWN>	6EVClr/6Ar/6Clr	4.561	0.38	0.369	0.25	Low-E
DAR-016-006	<UNKNOWN>	6InsTS21/12/6Clr	4.595	0.16	0.096	0.25	Low-E
DAR-016-014	<UNKNOWN>	6TS21Gn/12/6Clr	4.607	0.161	0.095	0.25	Low-E
DAR-016-309	AGG	AGG CLASSIC Ctr 8/12/8	4.626	0.428	0.449	0.25	Clear
DAR-016-019	<UNKNOWN>	6Clr/12Ar/10.38ClrLam	4.628	0.45	0.455	0.25	Clear
DAR-016-016	<UNKNOWN>	6.38GyLam/12Ar/6.38ClrLam	4.651	0.332	0.221	0.25	Toned
DAR-016-313	AGG	AGG CLASSIC Ctr lam 6_12_6,38	4.66	0.466	0.475	0.25	Clear
DAR-016-020	<UNKNOWN>	6Gy/12Ar/6Gy	4.671	0.287	0.105	0.25	Toned
DAR-016-022	OCEANIA	6SpGy/12Ar/6Clr	4.671	0.168	0.045	0.25	Toned
DAR-016-021	OCEANIA	6Gy/12Ar/6Clr	4.672	0.314	0.222	0.25	Toned
DAR-016-308	AGG	AGG CLASSIC Ctr 6/12/6	4.675	0.467	0.469	0.25	Clear
DAR-016-311	AGG	AGG CLASSIC Gy 6/12/6	4.675	0.331	0.235	0.25	Clear
DAR-016-312	AGG	AGG CLASSIC Ctr lam 4_12_6,38	4.681	0.495	0.486	0.25	Clear
DAR-016-339	AGG	AGG CLASSIC Ctr 5/12/5	4.699	0.472	0.472	0.25	Clear
DAR-016-307	AGG	AGG CLASSIC Ctr 4/12/4	4.721	0.505	0.491	0.25	Clear
DAR-016-310	AGG	AGG CLASSIC Gy 4/12/4	4.721	0.388	0.305	0.25	Clear
DAR-016-015	<UNKNOWN>	6.38ClrLam/12/6.38ClrLam	4.736	0.441	0.463	0.25	Clear
DAR-016-001	GENERIC	6Clr/12/6Clr	4.752	0.468	0.47	0.25	Clear
DAR-016-004	<UNKNOWN>	6InsEG/12/6Clr	4.755	0.282	0.348	0.25	Low-E
DAR-016-013	<UNKNOWN>	6SpGn/12/6Clr	4.761	0.284	0.353	0.25	Toned
DAR-016-018	<UNKNOWN>	6SpGy/6Ar/6Clr	4.928	0.178	0.045	0.25	Toned

**KEY**

Gy = Grey, Ntl = Neutral, Gn = Green, Clr = Clear, B = Blue, Bz = Bronze, Lam = Laminate, ComPls = Comfort Plus, SolT - SolTech, Sp = Super, ET = Energy Tech, EVan = Evantage, AZT = Solar Cool Azuria, Sngy = Sunergy.

**NOTES**

1. Percentage improvement figures are compared with using base-case Generic Window 1 (3mm clear in standard aluminium frame)
2. A negative percentage improvement figure indicates performance worse than the base-case window
3. A positive percentage improvement figure indicates performance better than the base-case window
4. Maximum air infiltration is 5.0 L/s.m2 at a positive pressure difference of 75Pa as measured according to AS 2047
5. Static performance (U, SHFC, Tvw, Tdw) Calculated using Window 5.2 and Therm 5.2 software (LBNL), 2000-2003
6. Annual energy performance (stars and % improvements) calculated using Nationwide House Energy Rating Software (AccuRate)
7. Results disclosed at National fenestration Rating Council (NFRC) regulations

## General Configuration

All raw joints need to be sealed with small joint sealer or foam tab option.

Fabrication

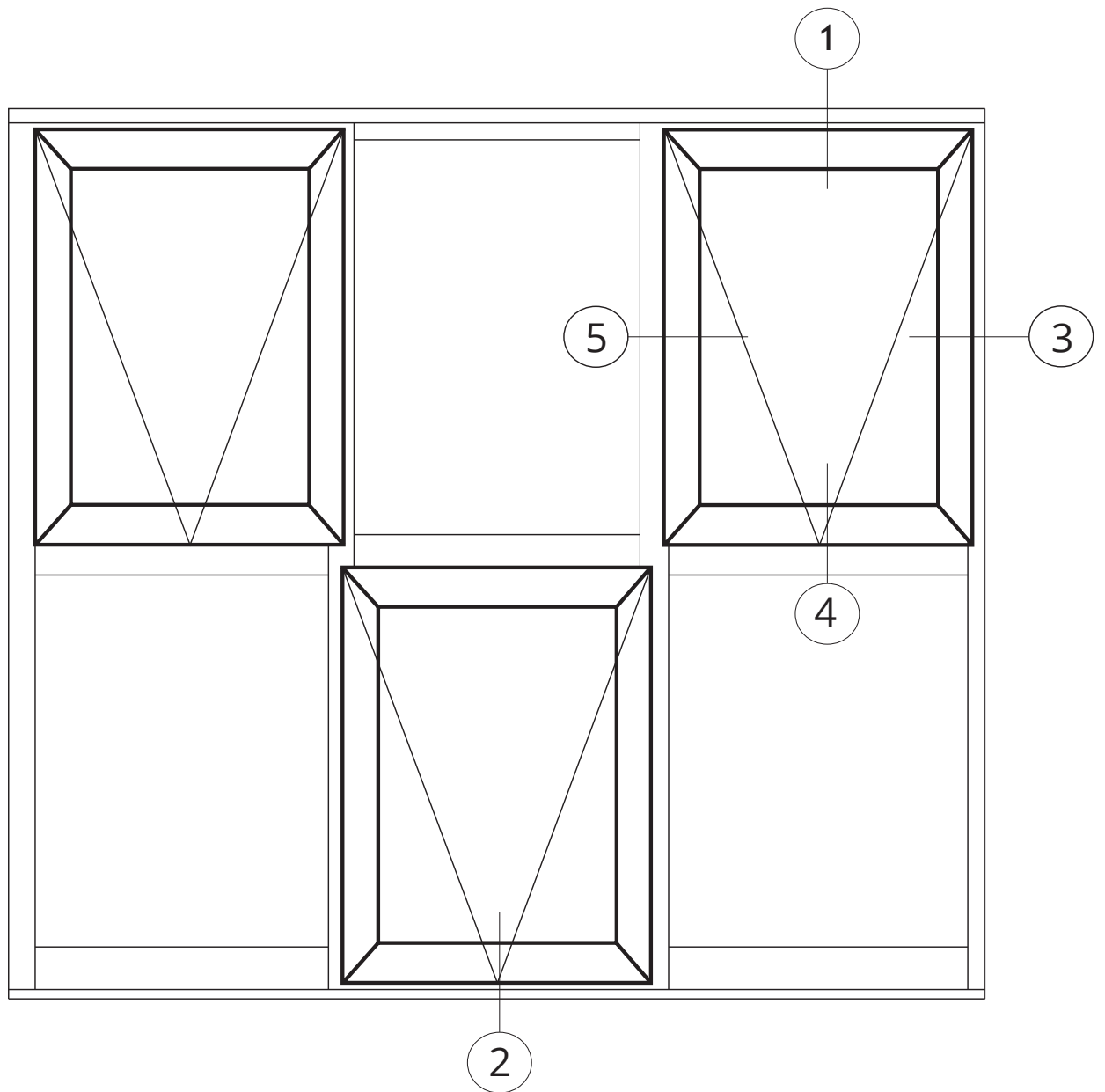

See also: Disclaimer and Copyright information on page 3

# 100mm Centre Single Glazed

All raw joints need to be sealed with small joint sealer or foam tab option.

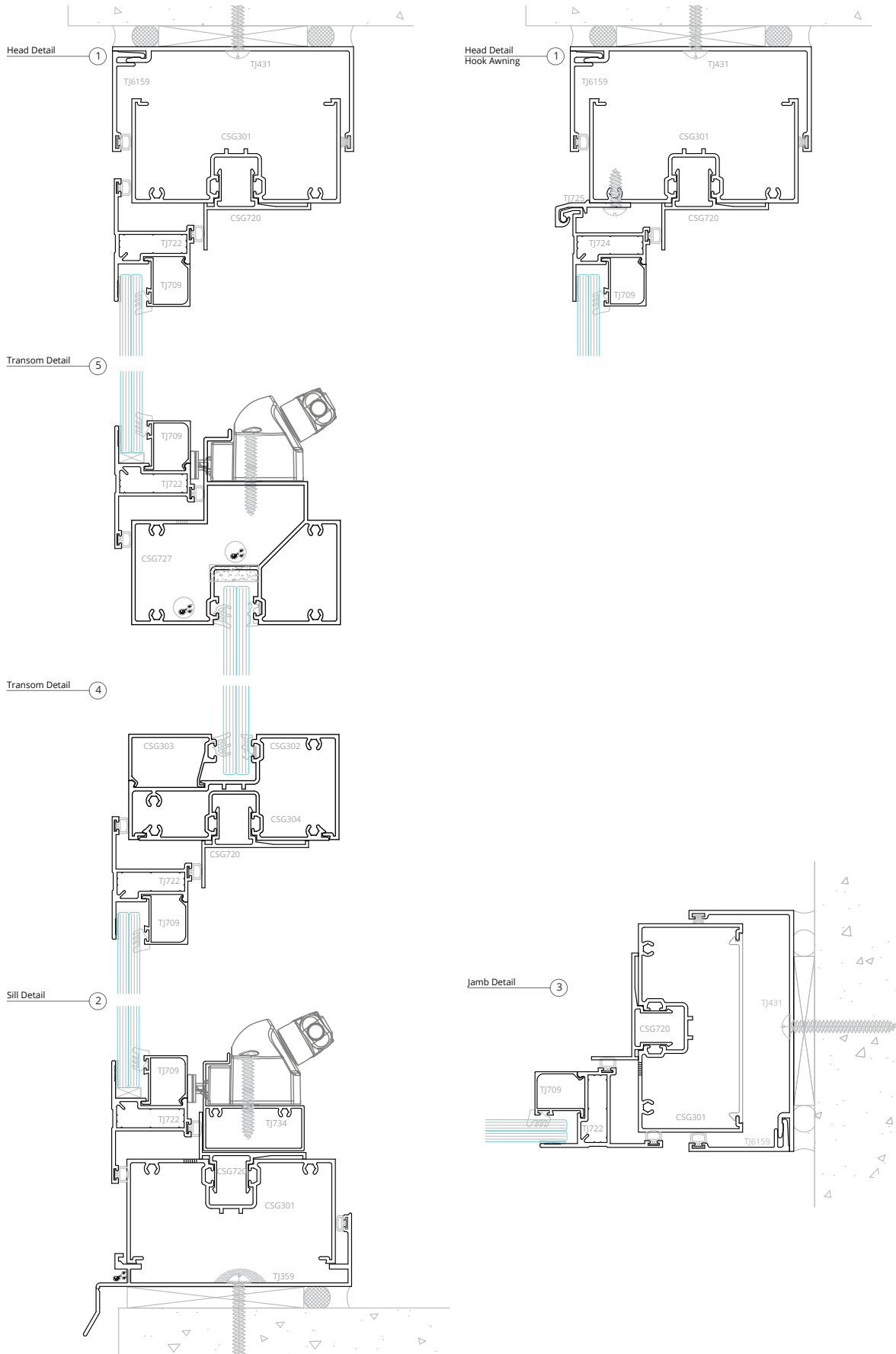

Fabrication

See also: Disclaimer and Copyright information on page 3

# 100mm Centre Single Glazed - Head and Sill

All raw joints need to be sealed with small joint sealer or foam tab option.

Fabrication

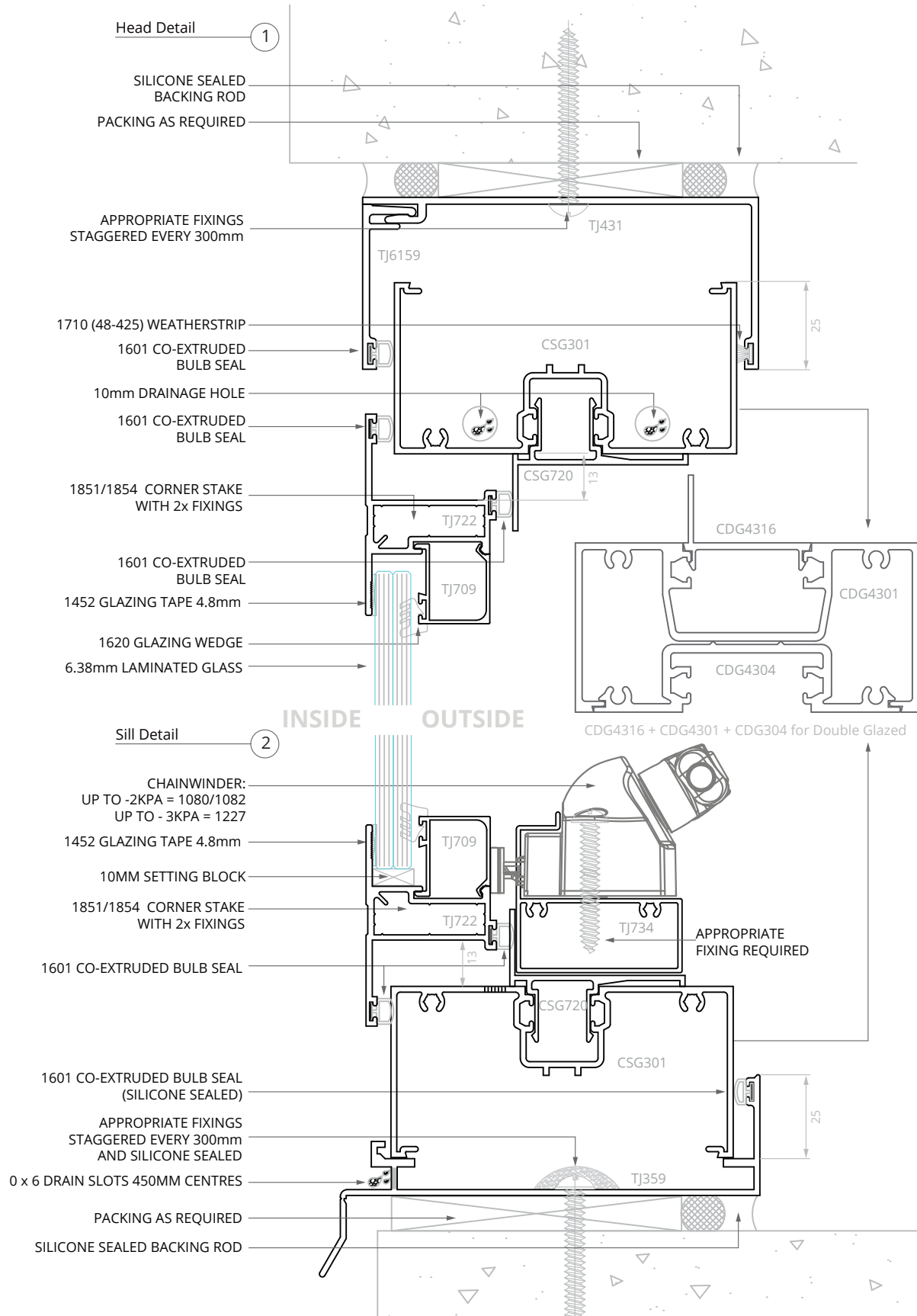

See also: Disclaimer and Copyright information on page 3

# 100mm Centre Single Glazed - Transom

All raw joints need to be sealed with small joint sealer or foam tab option.

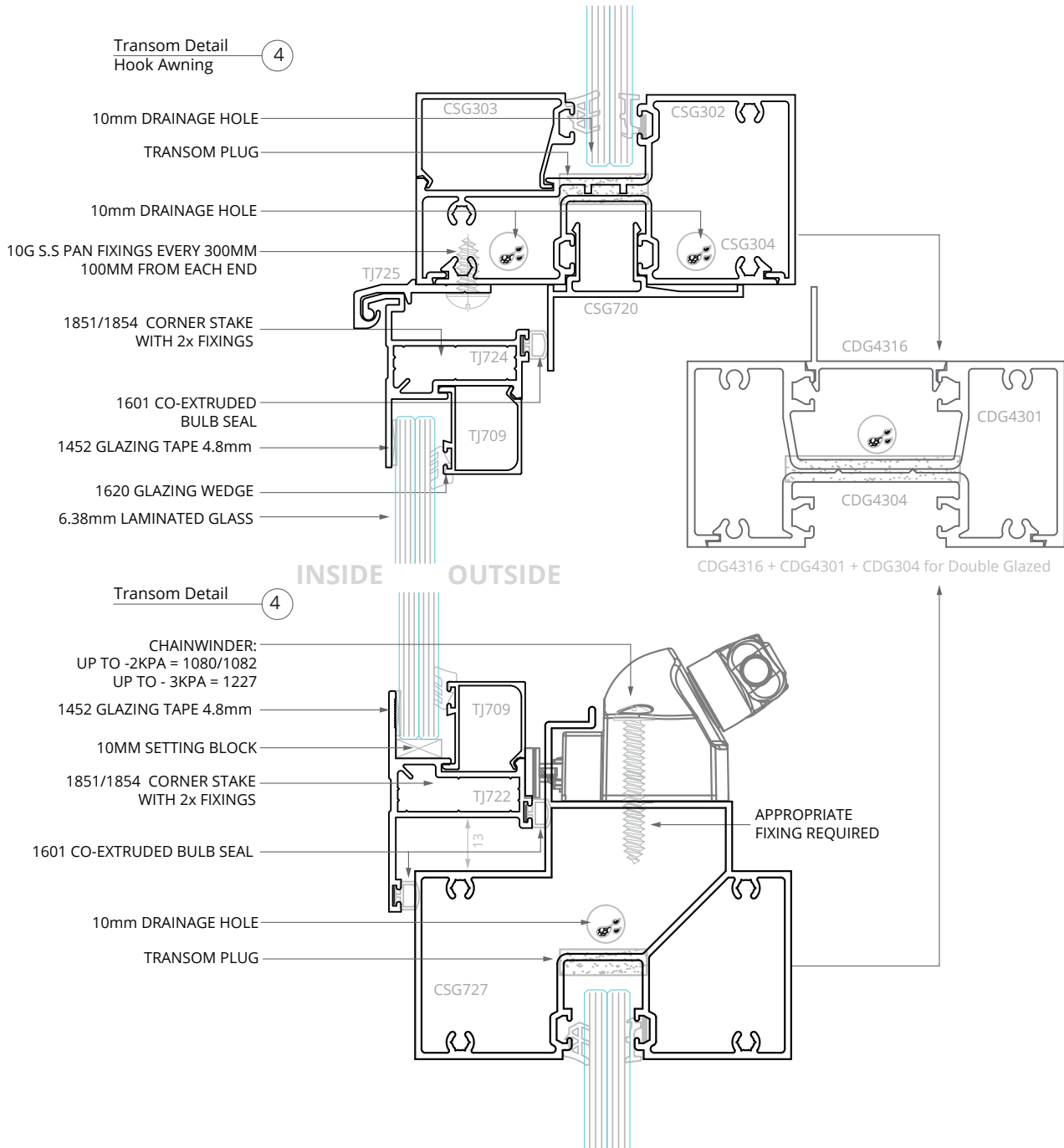

Fabrication

See also: Disclaimer and Copyright information on page 3

### 100mm Centre Double Glazed - Jamb

All raw joints need to be sealed with small joint sealer or foam tab option.

Fabrication

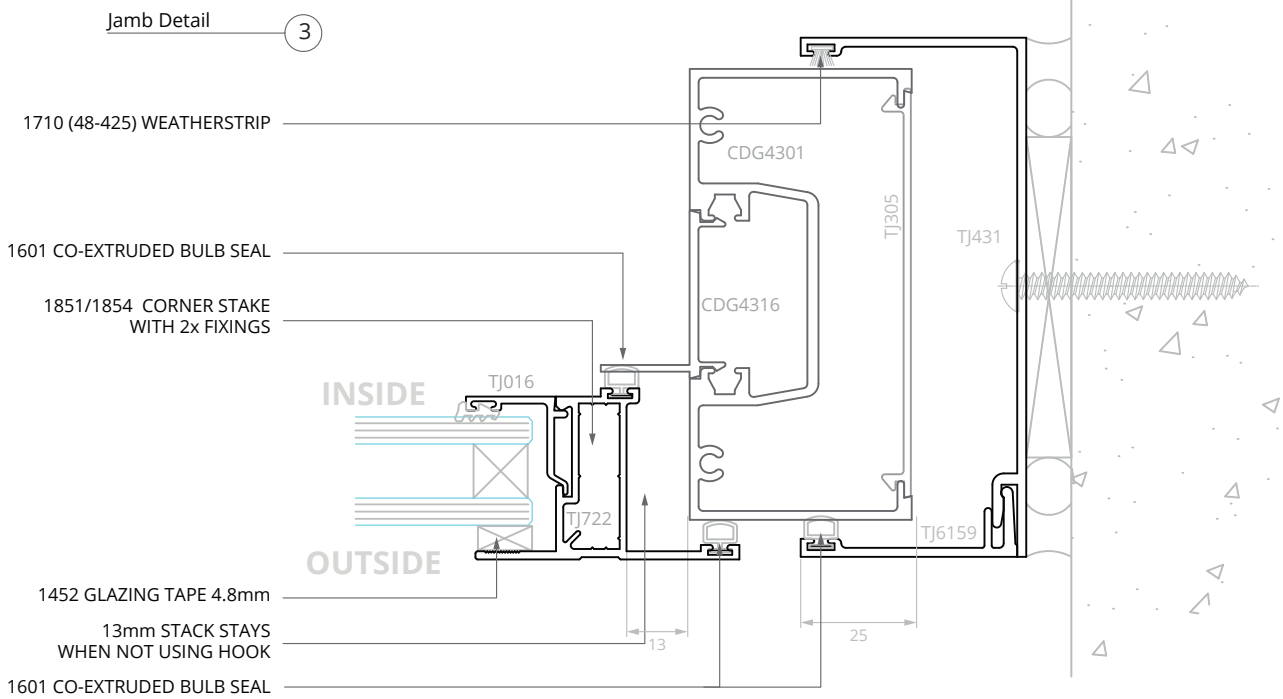

### 100mm Centre Single Glazed - Jamb

All raw joints need to be sealed with small joint sealer or foam tab option.

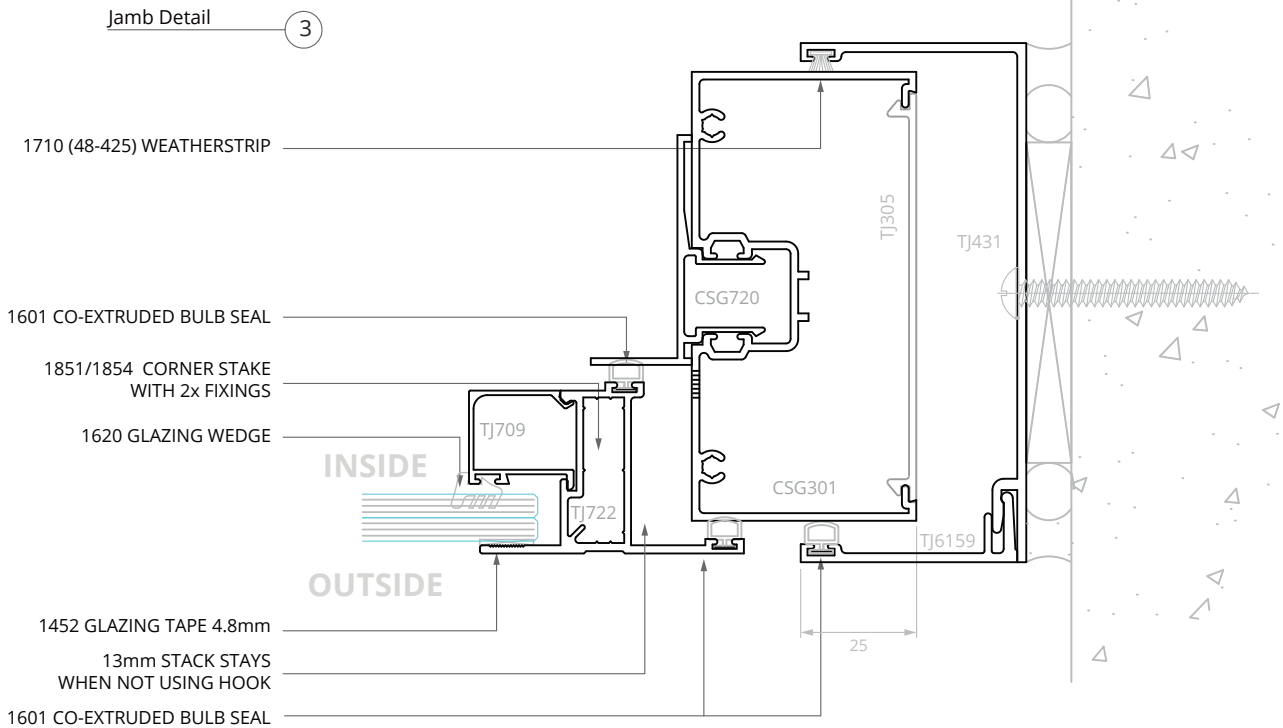

See also: Disclaimer and Copyright information on page 3

# 35MM AWNING

## 100mm Front Single Glazed

All raw joints need to be sealed with small joint sealer or foam tab option.

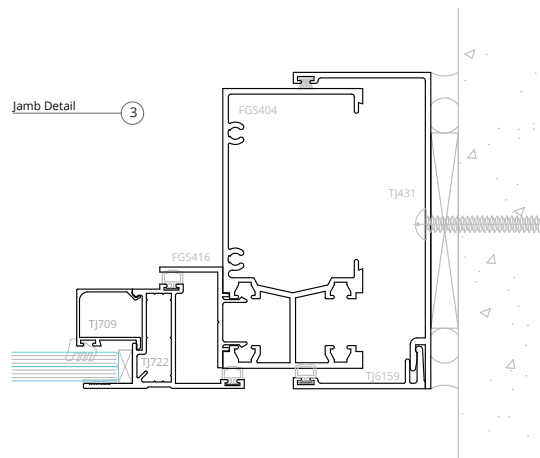
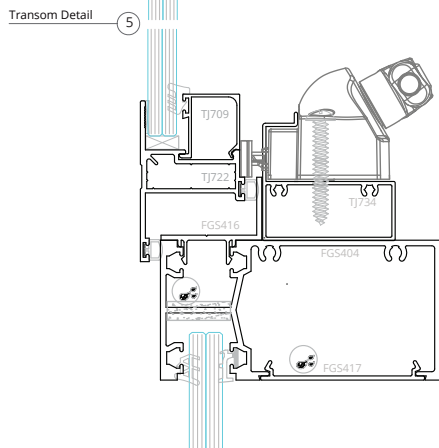
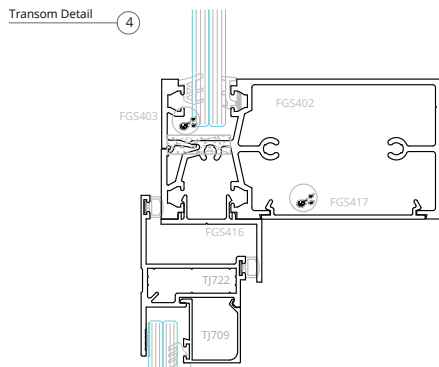
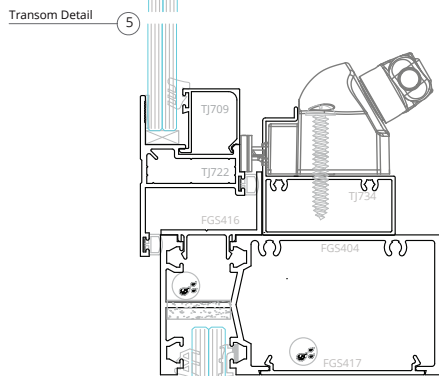
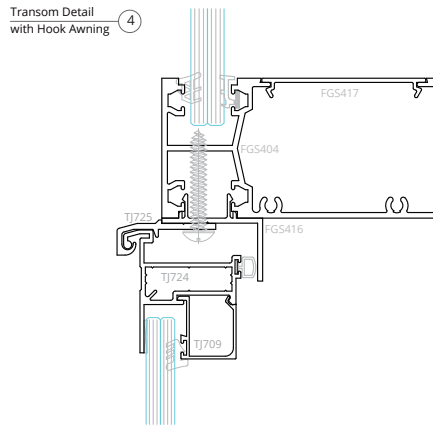
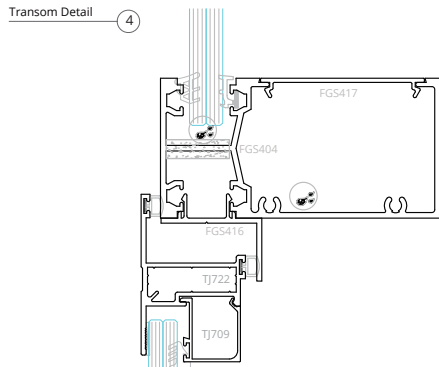

Fabrication

See also: Disclaimer and Copyright information on page 3

# 100mm Centre Single Glazed - Head and Sill

All raw joints need to be sealed with small joint sealer or foam tab option.

Fabrication

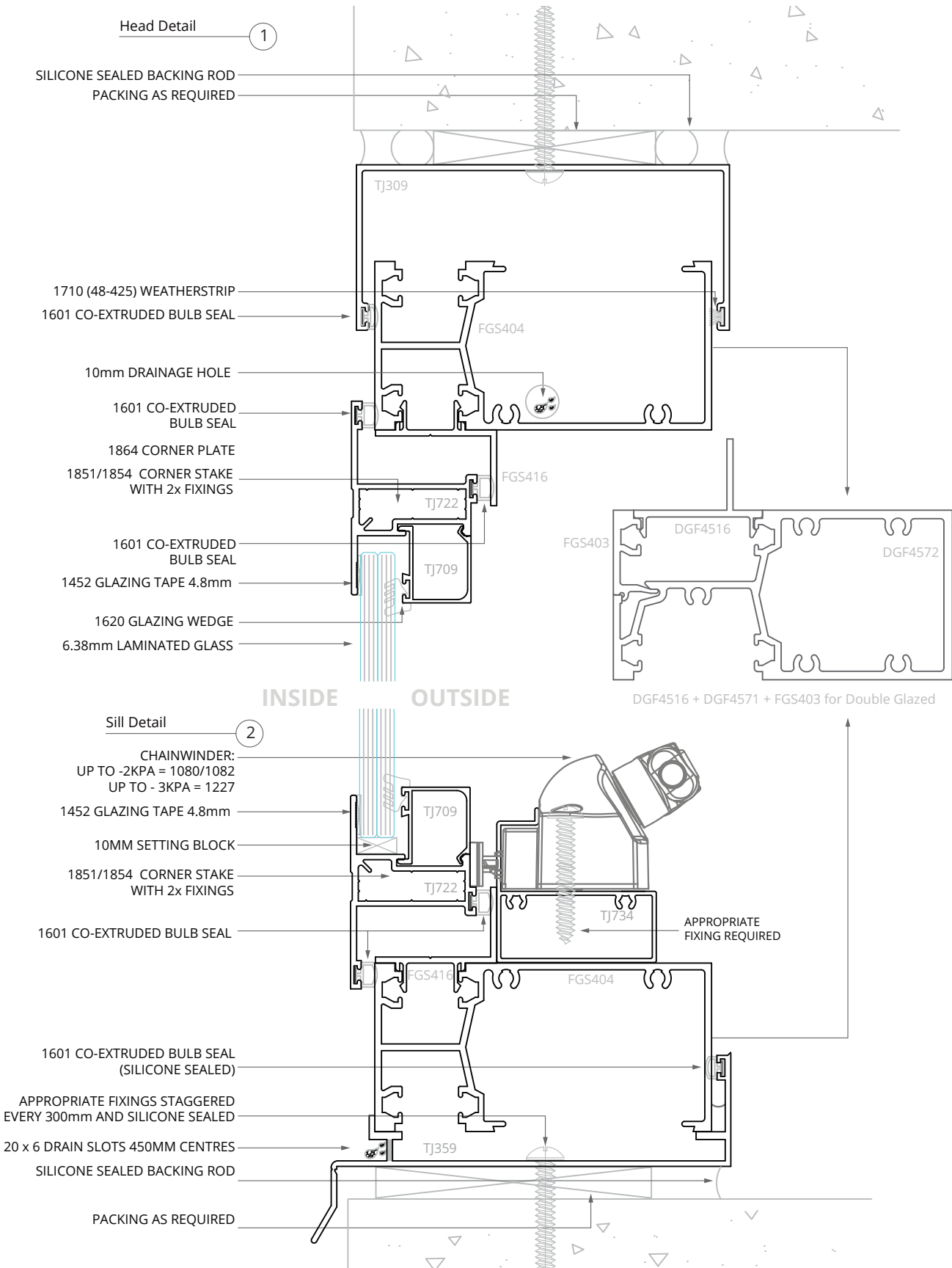

See also: Disclaimer and Copyright information on page 3

### 100mm Front Double Glazed - Jamb

All raw joints need to be sealed with small joint sealer or foam tab option.

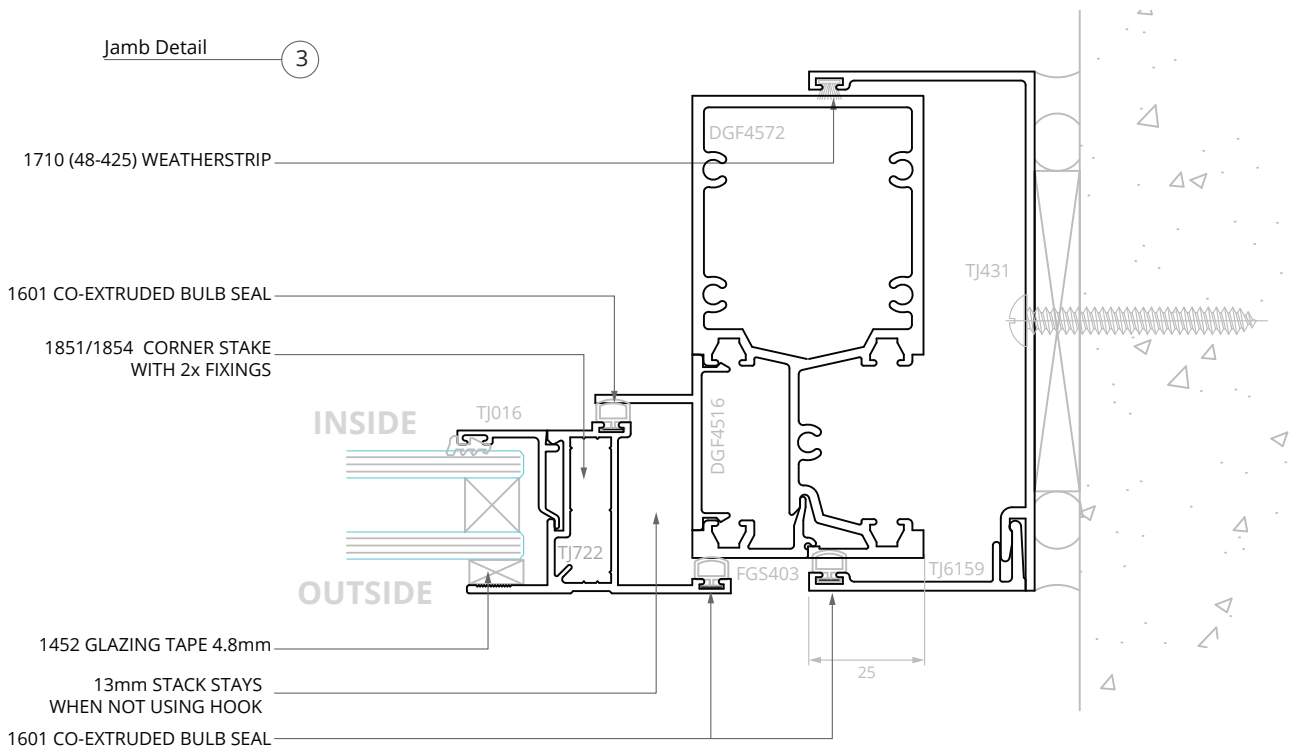

### 100mm Front Single Glazed - Jamb

All raw joints need to be sealed with small joint sealer or foam tab option.

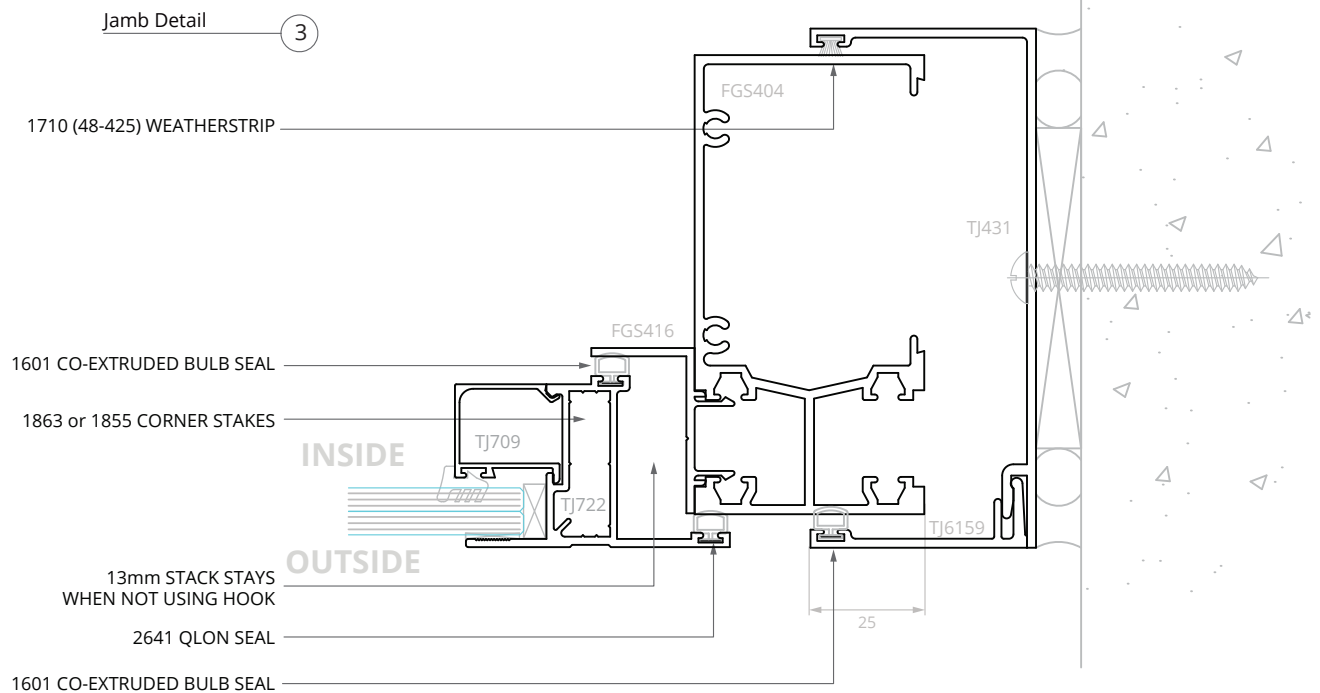

Fabrication

See also: Disclaimer and Copyright information on page 3

# 100mm Front Single Glazed - Transom

All raw joints need to be sealed with small joint sealer or foam tab option.

Fabrication

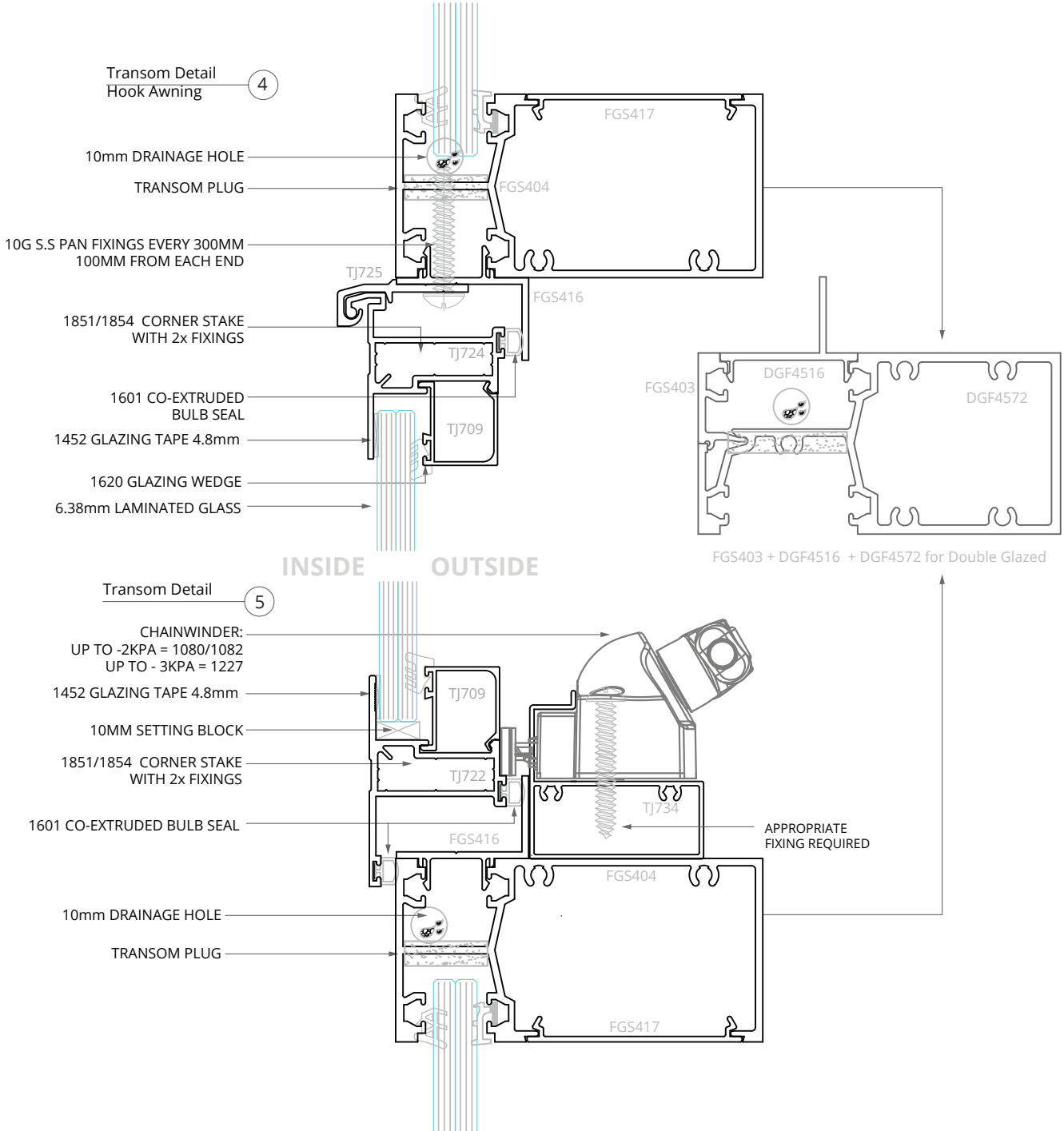

See also: Disclaimer and Copyright information on page 3

# 150mm Centre Single Glazed

All raw joints need to be sealed with small joint sealer or foam tab option.

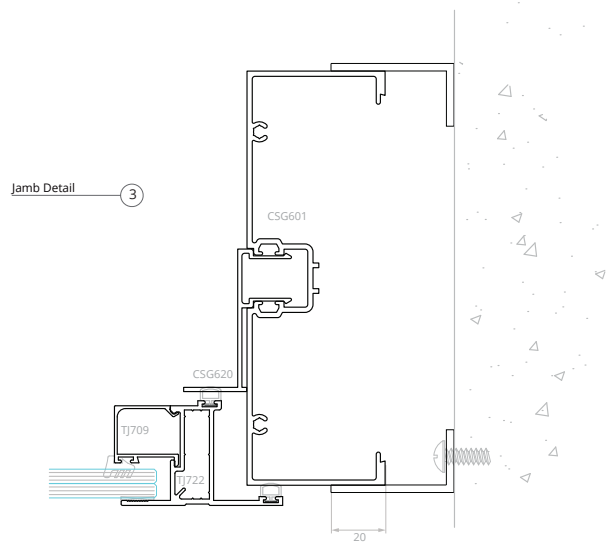
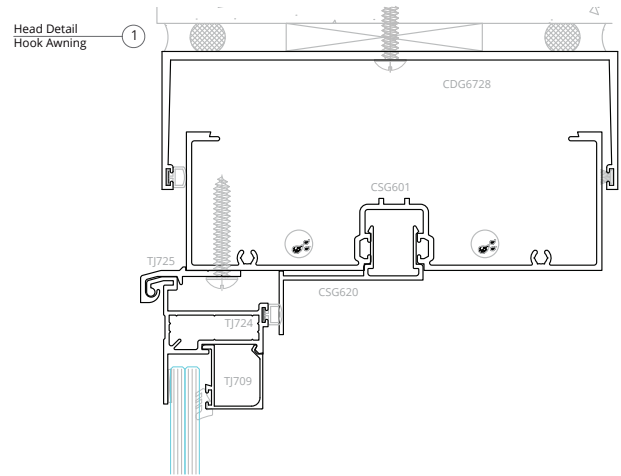
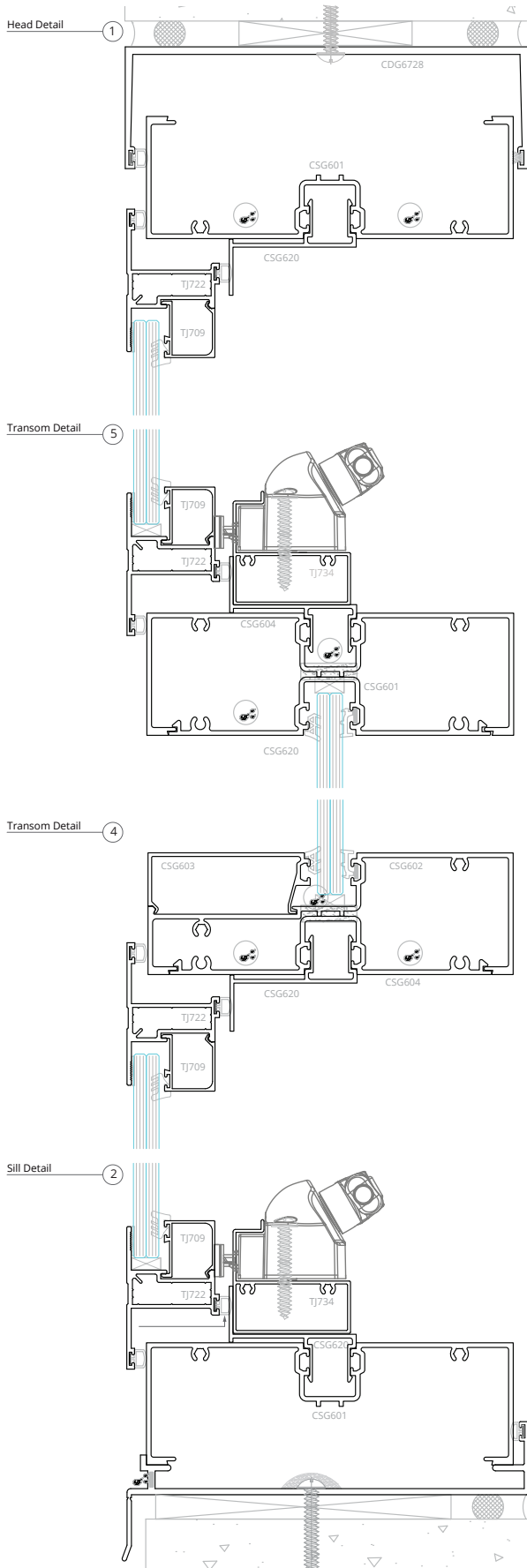

Fabrication

See also: Disclaimer and Copyright information on page 3

# 150mm Centre Single Glazed - Head and Sill

All raw joints need to be sealed with small joint sealer or foam tab option.

Fabrication

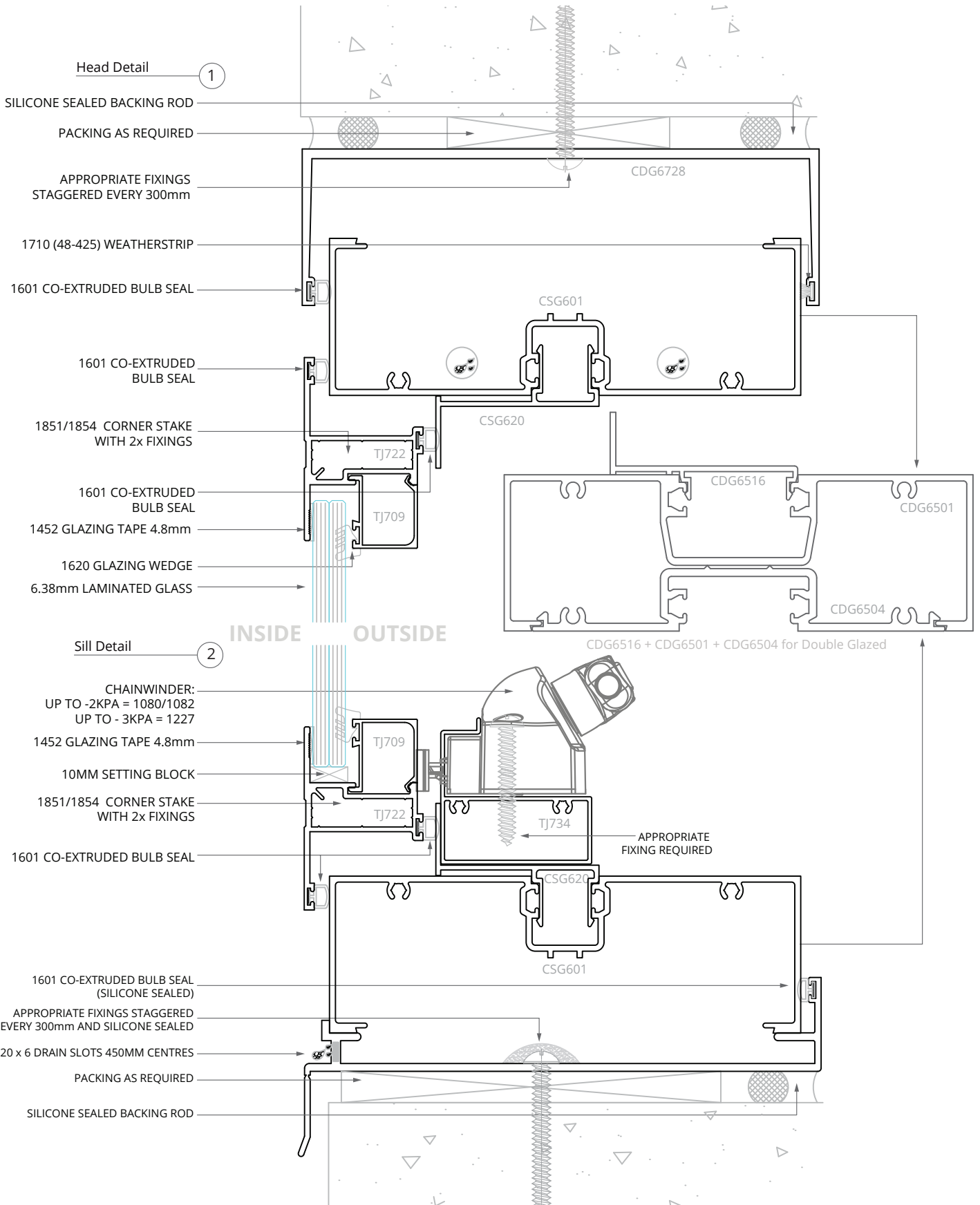

See also: Disclaimer and Copyright information on page 3

### 150mm Centre Double Glazed - Jamb

All raw joints need to be sealed with small joint sealer or foam tab option.

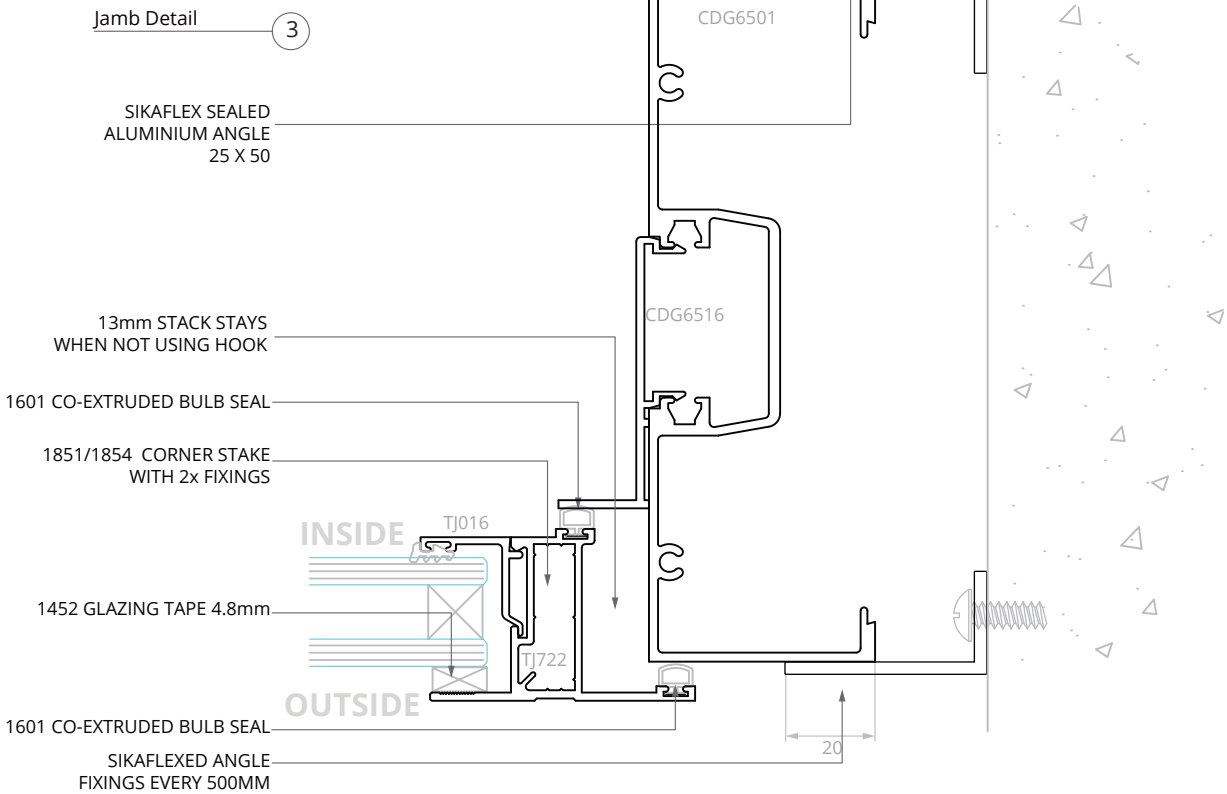

Fabrication

### 150mm Centre Single Glazed - Jamb

All raw joints need to be sealed with small joint sealer or foam tab option.

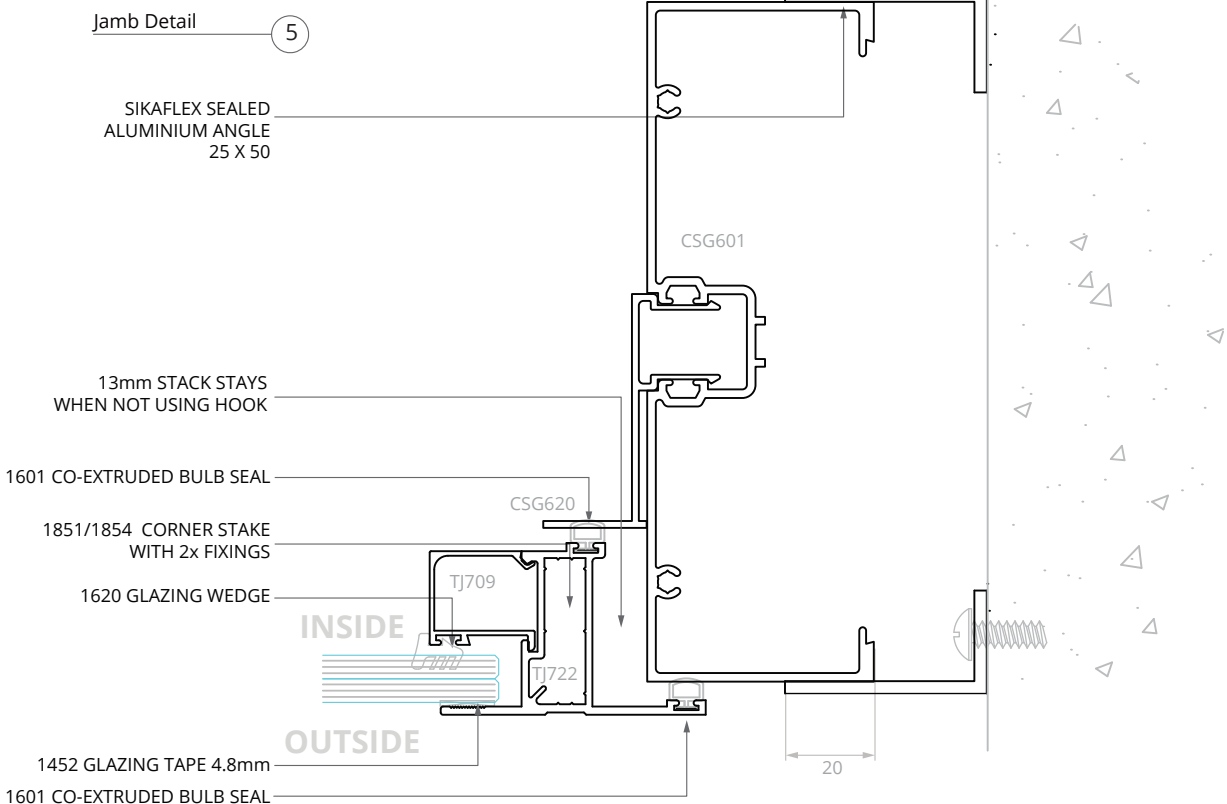

See also: Disclaimer and Copyright information on page 3

# 150mm Centre Single Glazed - Transom

All raw joints need to be sealed with small joint sealer or foam tab option.

Fabrication

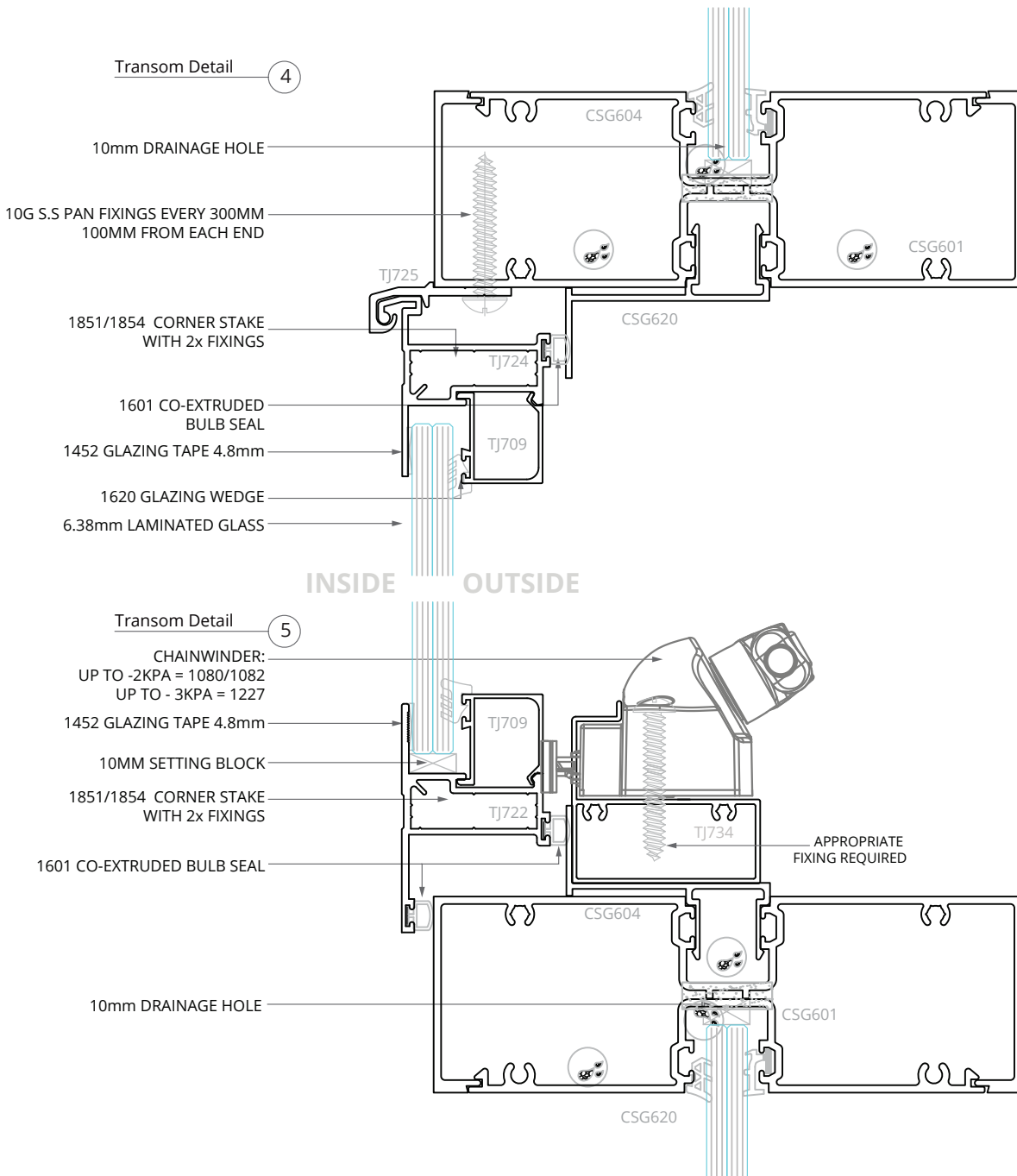

See also: Disclaimer and Copyright information on page 3

# 150mm Front Single Glazed

All raw joints need to be sealed with small joint sealer or foam tab option.

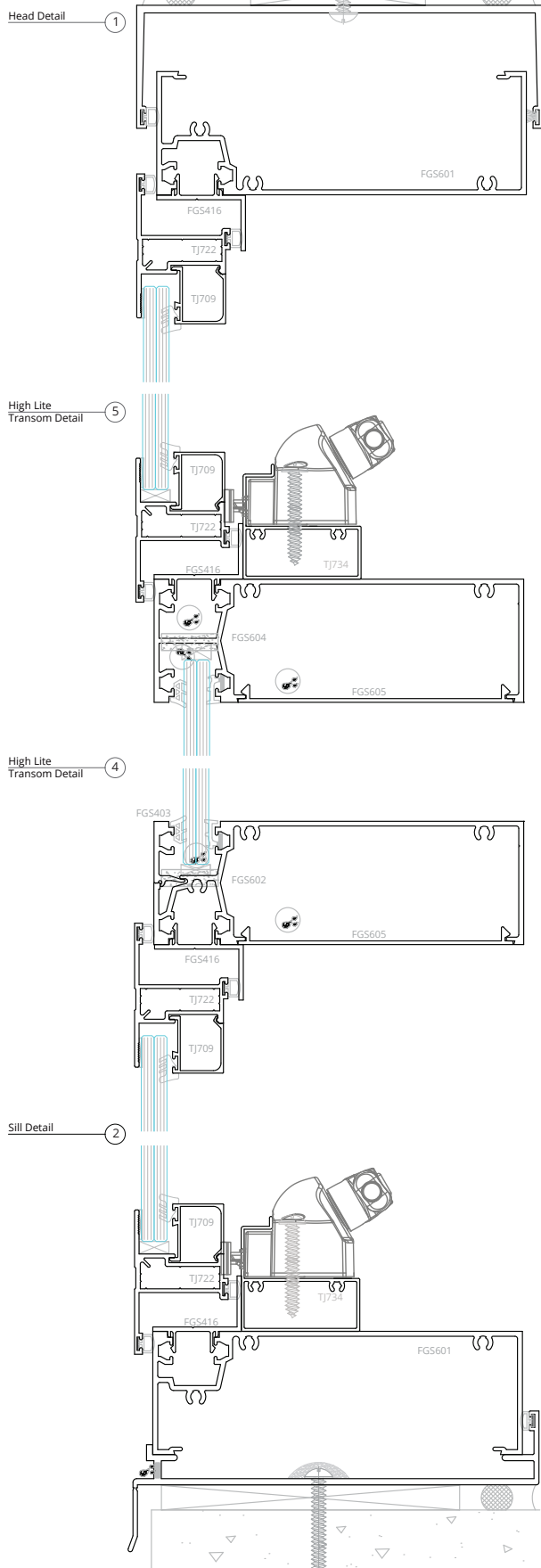

Fabrication

See also: Disclaimer and Copyright information on page 3

# 150mm Front Single Glazed - Head and Sill

All raw joints need to be sealed with small joint sealer or foam tab option.

Fabrication

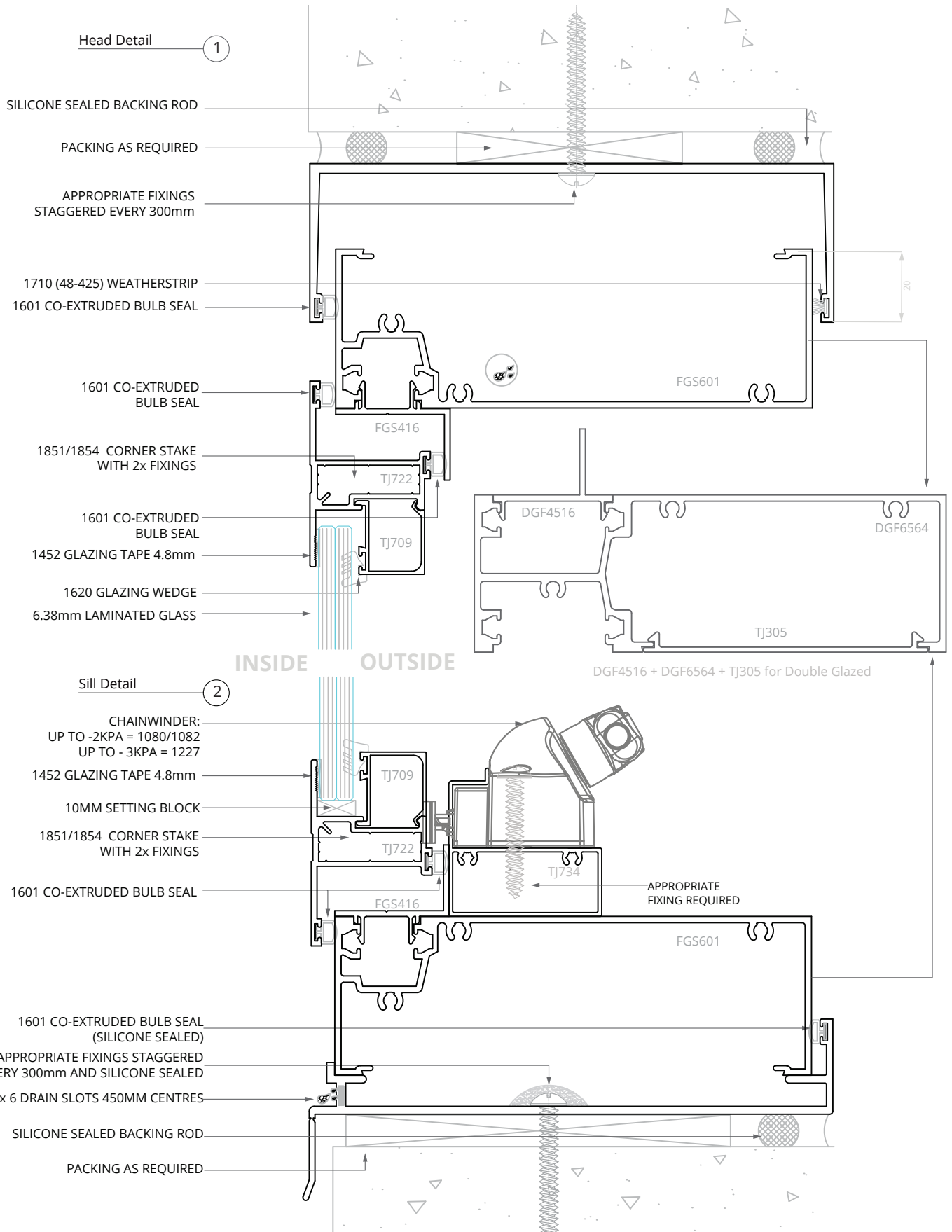

See also: Disclaimer and Copyright information on page 3

### 150mm Front Double Glazed - Jamb

All raw joints need to be sealed with small joint sealer or foam tab option.

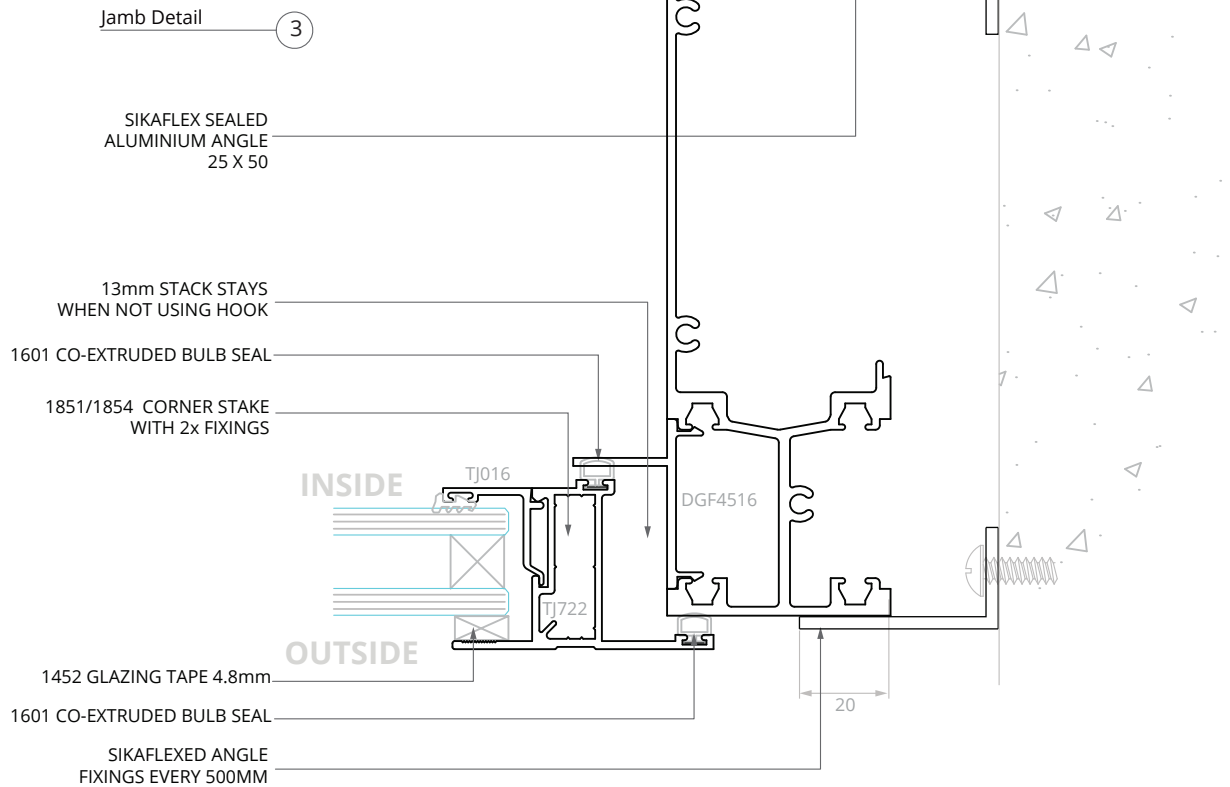

### 150mm Front Single Glazed - Jamb

All raw joints need to be sealed with small joint sealer or foam tab option.

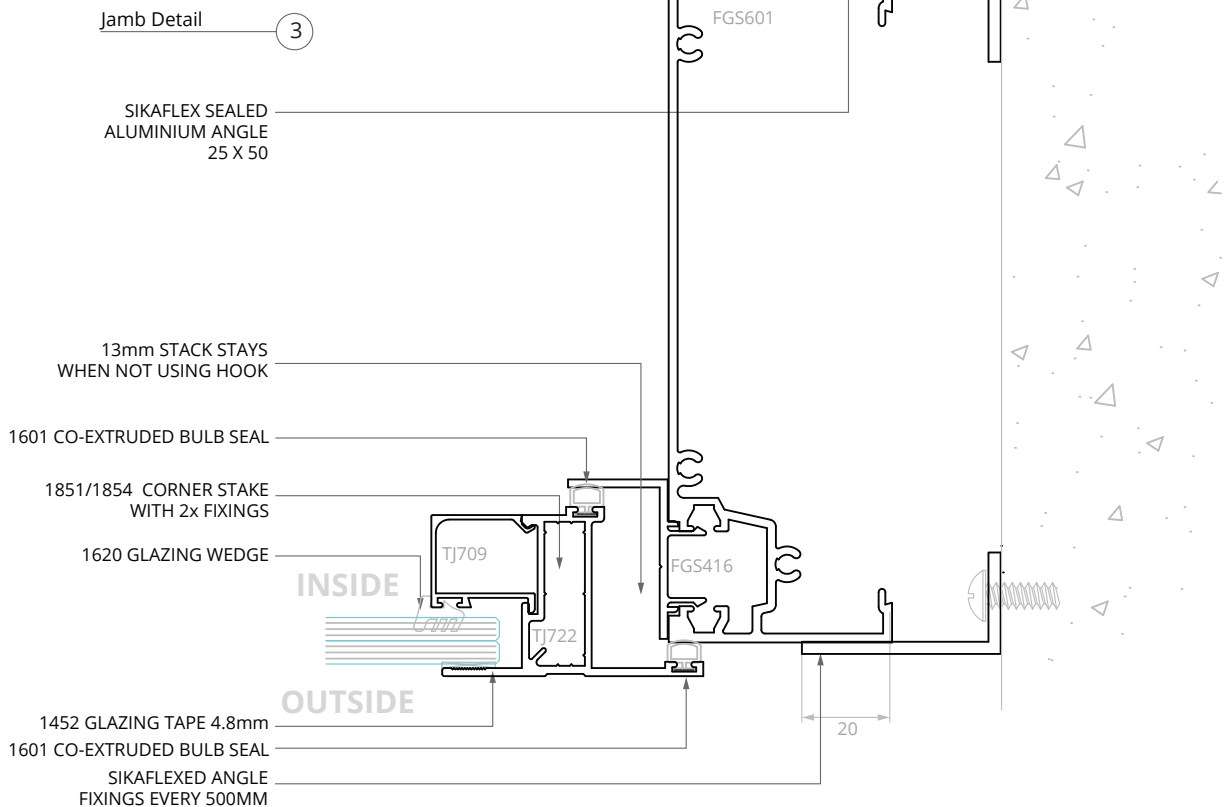

See also: Disclaimer and Copyright information on page 3

# 150mm Front Single Glazed - Transom

All raw joints need to be sealed with small joint sealer or foam tab option.

Fabrication

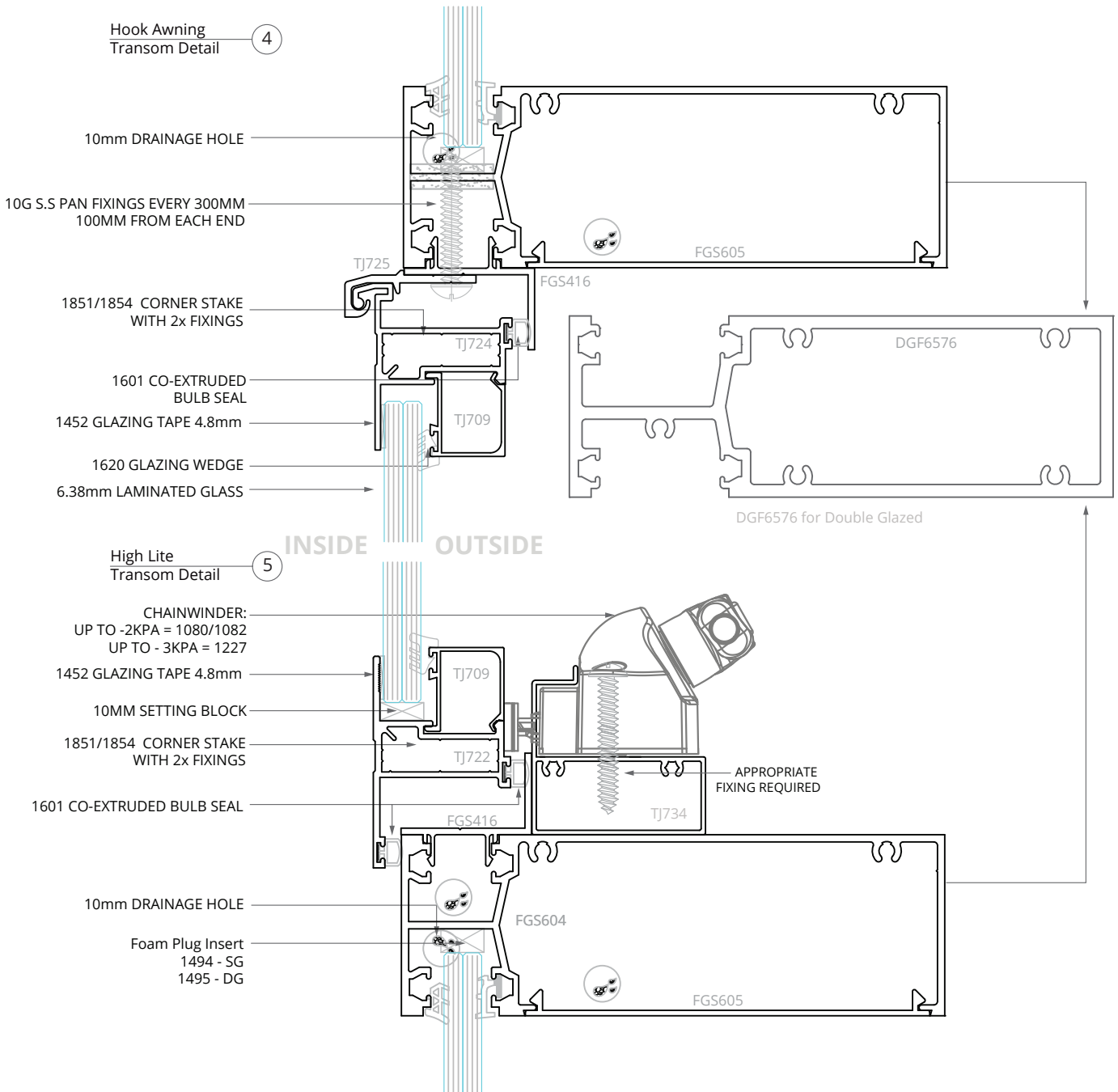

See also: Disclaimer and Copyright information on page 3

## Electric Chainwinder Box

All raw joints need to be sealed with small joint sealer or foam tab option.

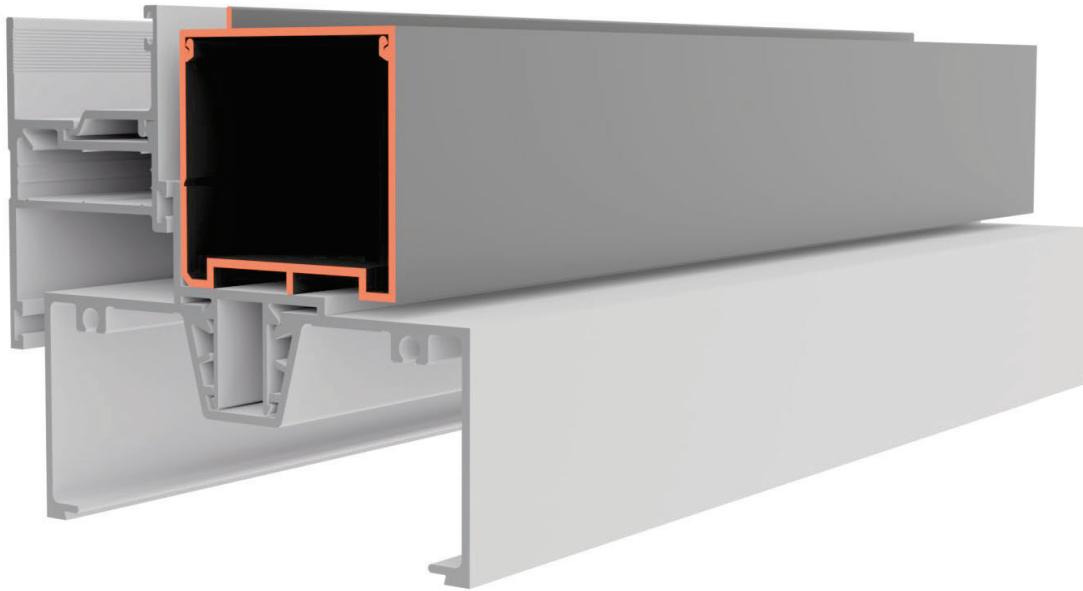

Fabrication

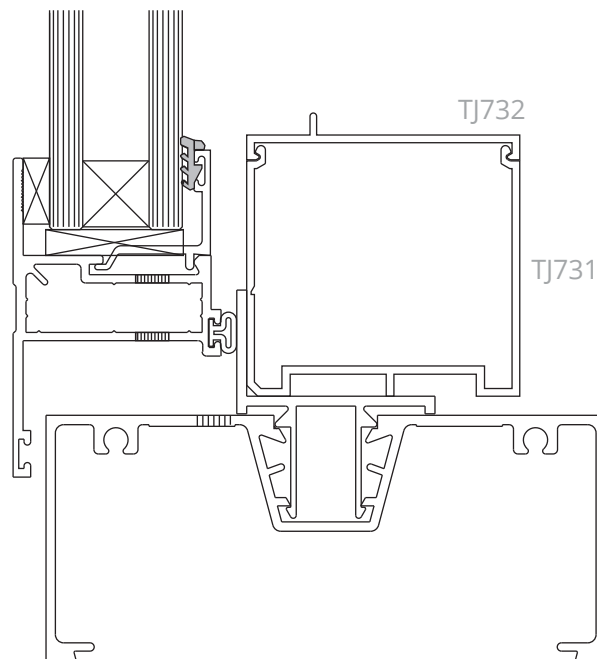

See also: Disclaimer and Copyright information on page 3

# Machining

All raw joints need to be sealed with small joint sealer or foam tab option.

Cutting Formula: For 101.6mm x 45mm Single Centre Frame with Stays

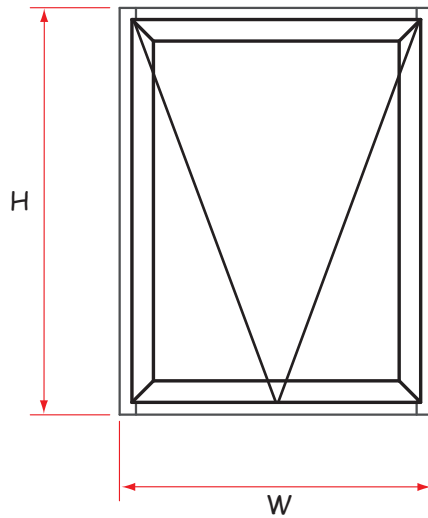

Fabrication

35mm Awning w/ Stays V1 March 2024				
NOTE: MEASUREMENTS ARE BASED ON OVERALL FRAME SIZE(DO NOT INCLUDE SUB HEAD/SILLS)				
CODES	DESCRIPTION	QUANTITY	SIZES	
TJ301	JAMBS	2	H	
	HEAD	1	W - 89	
	SILL	1	W - 89	
TJ720	AWNING STOP (Vertical)	2	H - 51	NOTE 1
	AWNING STOP (Horizontal)	2	W - 51	
TJ722/TJ723	SASH RAIL (Vertical)	2	H - 67	
	SASH RAIL (Horizontal)	2	W - 67	
TJ709/TJ016	SASH BEAD (Vertical)	2	H - 188	
	SASH BEAD (Horizontal)	2	W - 148	
TJ737	CHAINWINDER SUPPORT	1	W - 95	
<b>GLASS SIZES</b>		<b>QUANTITY</b>	<b>HEIGHT</b>	<b>WIDTH</b>
		1	H - 161	W - 161
<b>FLYSCREEN</b>				
HFF180	FLY SCREEN VERTICALS	2	H - 141	
HFF180	FLY SCREEN HORIZONTALS	2	W - 99	
<b>NOTE 1</b>	MITRED AT ENDS. REFER TO THE MITRING TABLE FOR CORRESPONDING FRAME AND AWNING STOP AND RESPECTIVE CUTTING FORMULA			
<b>NOTE 2</b>	VERTICAL RAIL CUTTING FORMULA IS PREMACHINING CROPS			

\*Electric chainwinder box length is equal to sill length

See also: Disclaimer and Copyright information on page 3

All raw joints need to be sealed with small joint sealer or foam tab option.

Cutting Formula: For 101.6mm x 45mm Single Centre Frame with Plant on Hook

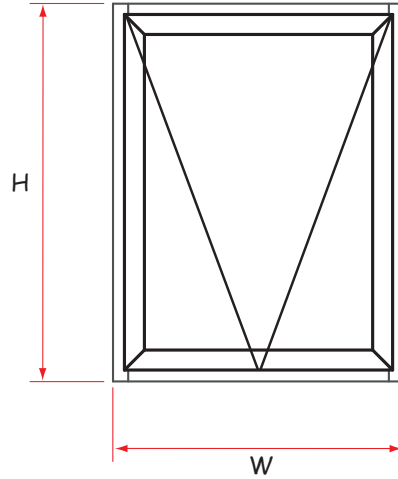

Fabrication

35mm Awning w/ Hook Sash V1 March 2024				
NOTE: MEASUREMENTS ARE BASED ON OVERALL FRAME SIZE(DO NOT INCLUDE SUB HEAD/SILLS)				
CODES	DESCRIPTION	QUANTITY	SIZES	
TJ301	JAMBS	2	H	
	HEAD	1	W- 89	
	SILL	1	W- 89	
TJ725	PLANT ON HOOK	1	W- 66	
TJ720	AWNING STOP (Vertical)	2	H - 51	NOTE 1
	AWNING STOP (Horizontal)	2	W - 51	
TJ722/TJ723	SASH RAIL (Vertical)	2	H - 66	NOTE 2
	SASH RAIL (Horizontal)	1	W - 66	
TJ724	HOOK SASH RAIL	1	W - 92	
TJ709/TJ016	SASH BEAD (Vertical)	2	H - 189	
	SASH BEAD (Horizontal)	2	W - 148	
TJ737	CHAINWINDER SUPPORT	1	W - 106	
<b>GLASS SIZES</b>		<b>QUANTITY</b>	<b>HEIGHT</b>	<b>WIDTH</b>
		1	H - 162	W - 160
<b>FLYSCREEN</b>				
HFF180	FLY SCREEN VERTICALS	2	H - 141	
HFF180	FLY SCREEN HORIZONTALS	2	W - 99	
<b>NOTE 1</b>	MITRED AT ENDS. REFER TO THE MITRING TABLE FOR CORRESPONDING FRAME AND AWNING STOP AND RESPECTIVE CUTTING FORMULA			
<b>NOTE 2</b>	VERTICAL RAIL CUTTING FORMULA IS PREMACHINING CROPS			

\*Electric chainwinder box length is equal to sill length

See also: Disclaimer and Copyright information on page 3

All raw joints need to be sealed with small joint sealer or foam tab option.

Cutting Formula: For 100mm x 50mm Single Centre Frame with Stays

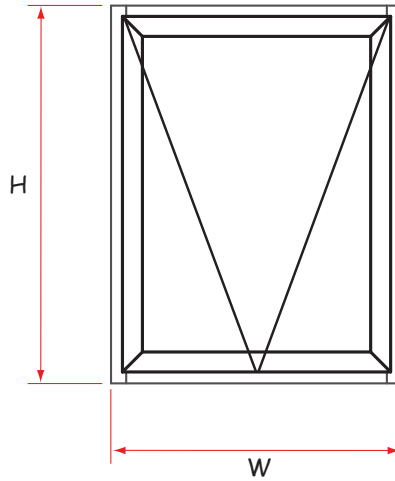

Fabrication

35mm Awning w/ Stays V1 March 2024				
NOTE: MEASUREMENTS ARE BASED ON OVERALL FRAME SIZE(DO NOT INCLUDE SUB HEAD/SILLS)				
CODES	DESCRIPTION	QUANTITY	SIZES	
CSG301	JAMBS	2	H	
	HEAD	1	W - 100	
	SILL	1	W - 100	
CSG720	AWNING STOP (Vertical)	2	H - 66	NOTE 1
	AWNING STOP (Horizontal)	2	W - 66	
TJ722/TJ723	SASH RAIL (Vertical)	2	H - 79	NOTE 2
	SASH RAIL (Horizontal)	2	W - 79	
TJ709/TJ016	SASH BEAD (Vertical)	2	H - 199	
	SASH BEAD (Horizontal)	2	W - 159	
TJ734	CHAINWINDER SUPPORT	1	W -106	
<b>GLASS SIZES</b>		<b>QUANTITY</b>	<b>HEIGHT</b>	<b>WIDTH</b>
		2	H - 172	W - 172
<b>FLYSCREEN</b>				
HFF180	FLY SCREEN VERTICALS	2	H - 155	
HFF180	FLY SCREEN HORIZONTALS	2	W - 110	
<b>NOTE 1</b>	MITRED AT ENDS. REFER TO THE MITRING TABLE FOR CORRESPONDING FRAME AND AWNING STOP AND RESPECTIVE CUTTING FORMULA			
<b>NOTE 2</b>	VERTICAL RAIL CUTTING FORMULA IS PREMACHINING CROPS			

\*Electric chainwinder box length is equal to sill length

See also: Disclaimer and Copyright information on page 3

All raw joints need to be sealed with small joint sealer or foam tab option.

Cutting Formula: For 100mm x 50mm Single Centre Frame with Plant on Hook

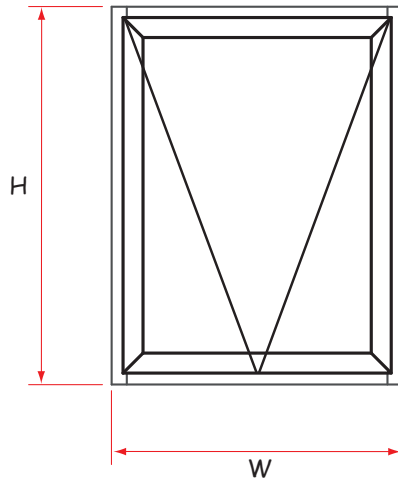

Fabrication

35mm Awning w/ Hook Sash V1 March 2024				
NOTE: MEASUREMENTS ARE BASED ON OVERALL FRAME SIZE(DO NOT INCLUDE SUB HEAD/SILLS)				
CODES	DESCRIPTION	QUANTITY	SIZES	
CSG301	JAMBS	2	H	
	HEAD	1	W - 100	
	SILL	1		
TJ725	PLANT ON HOOK	1	W - 78	
TJ734	CHAINWINDER SUPPORT	1	W - 106	
CSG720	AWNING STOP (Vertical)	2	H - 68	NOTE 1
	AWNING STOP (Horizontal)	2	W - 68	
TJ722/TJ723	SASH RAIL (Vertical)	2	H - 80	NOTE 2
	SASH RAIL (Horizontal)	1	W - 79	
TJ724	HOOK SASH RAIL	1	W - 103	
TJ709/TJ016	SASH BEAD (Vertical)	2	H - 159	
	SASH BEAD (Horizontal)	2	W - 200	
TJ734	CHAINWINDER SUPPORT	1	W - 106	
<b>GLASS SIZES</b>		<b>QUANTITY</b>	<b>HEIGHT</b>	<b>WIDTH</b>
		1	H - 174	W - 173
<b>FLYSCREEN</b>				
HFF180	FLY SCREEN VERTICALS	2	H - 155	
HFF180	FLY SCREEN HORIZONTALS	2	W - 110	
<b>NOTE 1</b>	MITRED AT ENDS. REFER TO THE MITRING TABLE FOR CORRESPONDING FRAME AND AWNING STOP AND RESPECTIVE CUTTING FORMULA			
<b>NOTE 2</b>	VERTICAL RAIL CUTTING FORMULA IS PREMACHINING CROPS			

\*Electric chainwinder box length is equal to sill length

See also: Disclaimer and Copyright information on page 3

All raw joints need to be sealed with small joint sealer or foam tab option.

### Machining Detail: Top Hung Adaptor TJ725



### Machining Details for Top Hung Adaptor TJ725

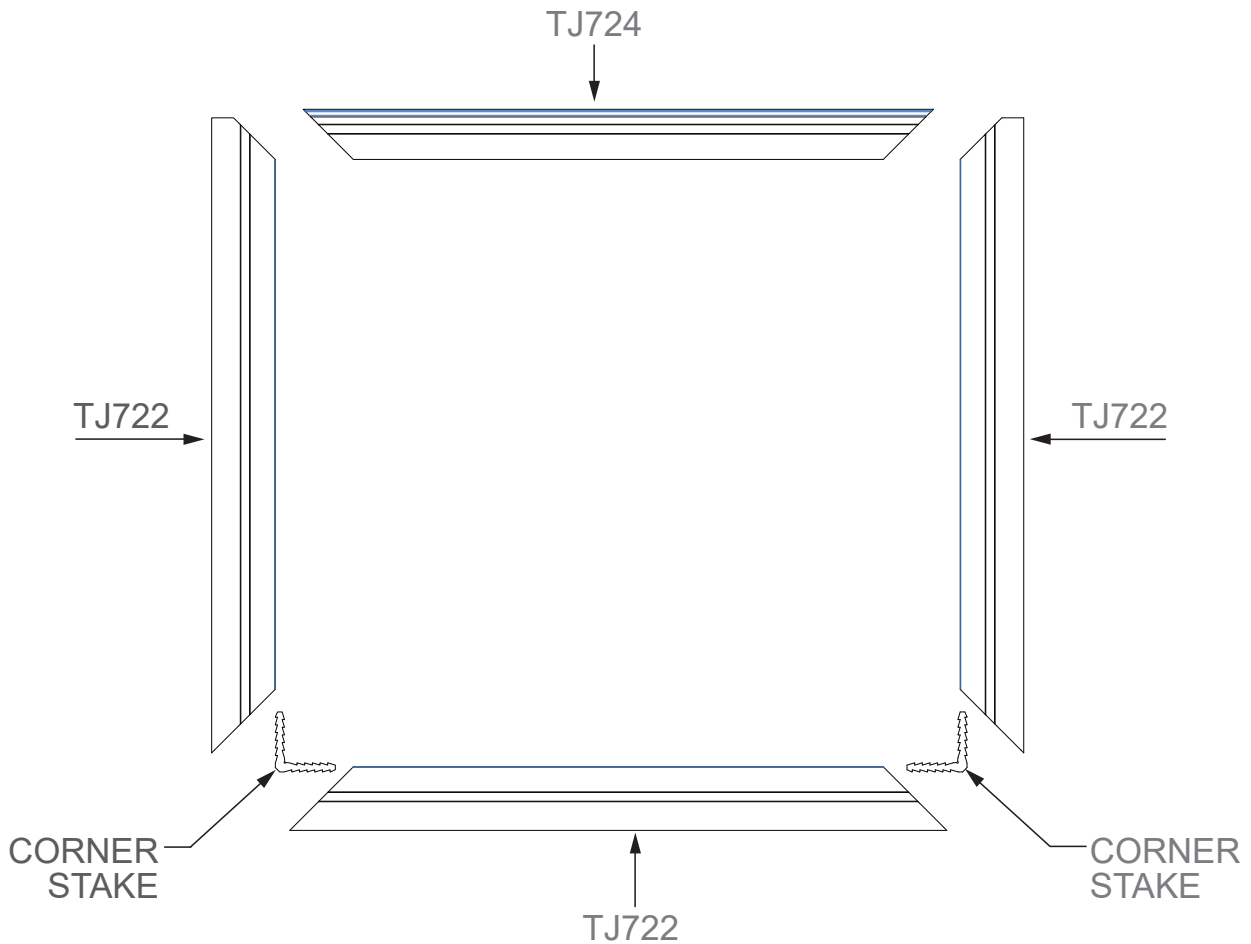

**NOTE:**

- Top-hook hinge sash size and weight limitations:
- 20kg max for sash widths between 400mm - 600mm
- 45kg max for sash widths of 600mm and above

See also: Disclaimer and Copyright information on page 3

All raw joints need to be sealed with small joint sealer or foam tab option.

### Machining Detail: Chainwinder for TJ737 & TJ734

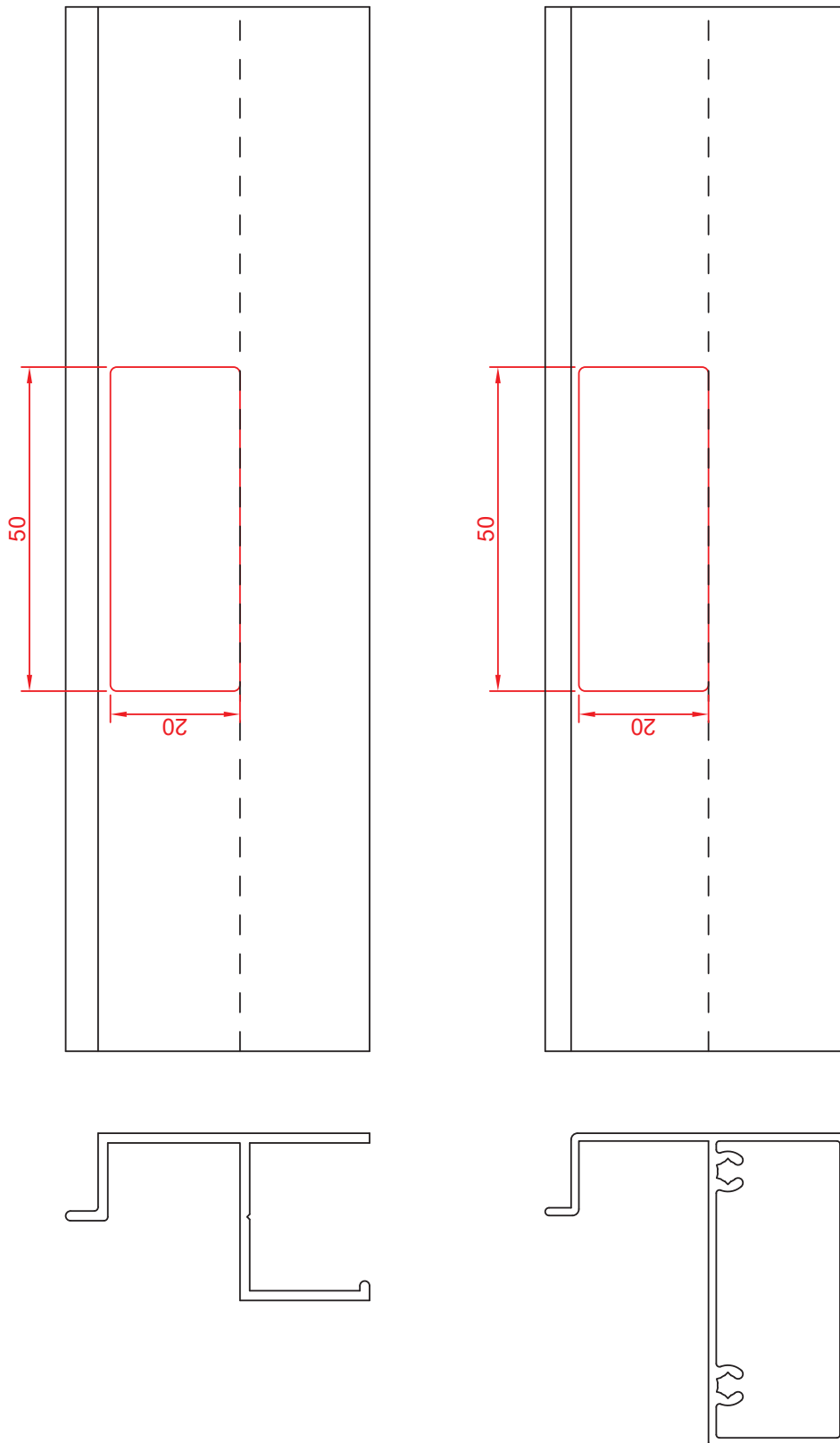

Fabrication

See also: Disclaimer and Copyright information on page 3

### Flyscreen Retention

All raw joints need to be sealed with small joint sealer or foam tab option.

#### Flyscreen Clips (top of jamb)



Flyscreen Clip  
Part No. 1892

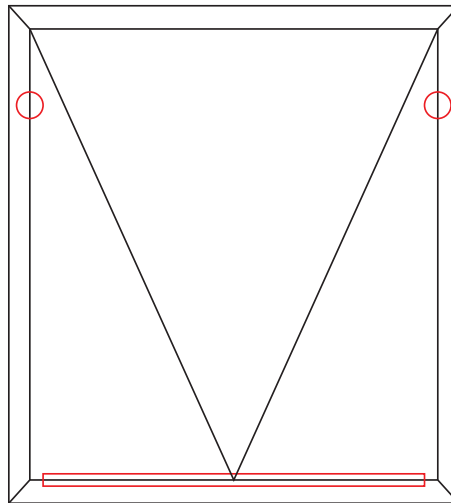

#### Retention leg on Chainwinder Box (bottom of screen)

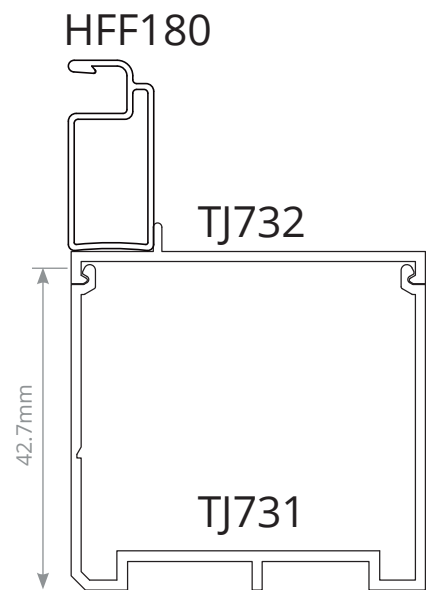
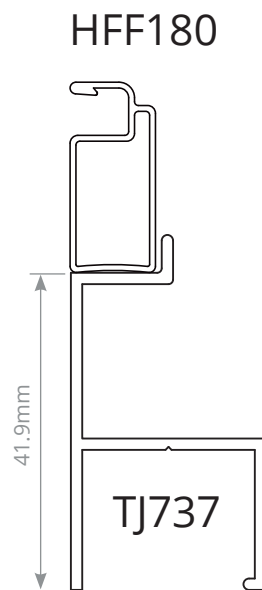
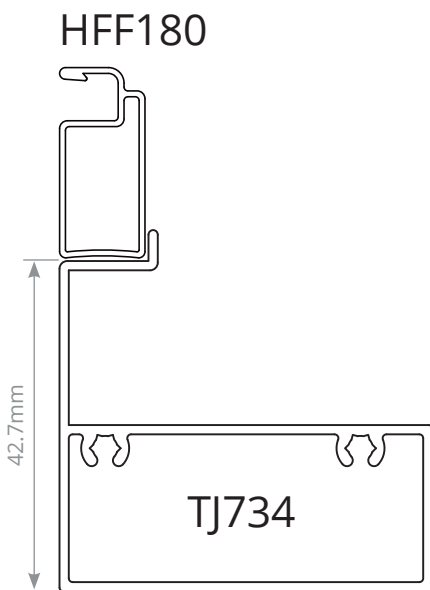

See also: Disclaimer and Copyright information on page 3

## Exploded Frame Assembly: Stays & Hook

All raw joints need to be sealed with small joint sealer or foam tab option.

### Assembly

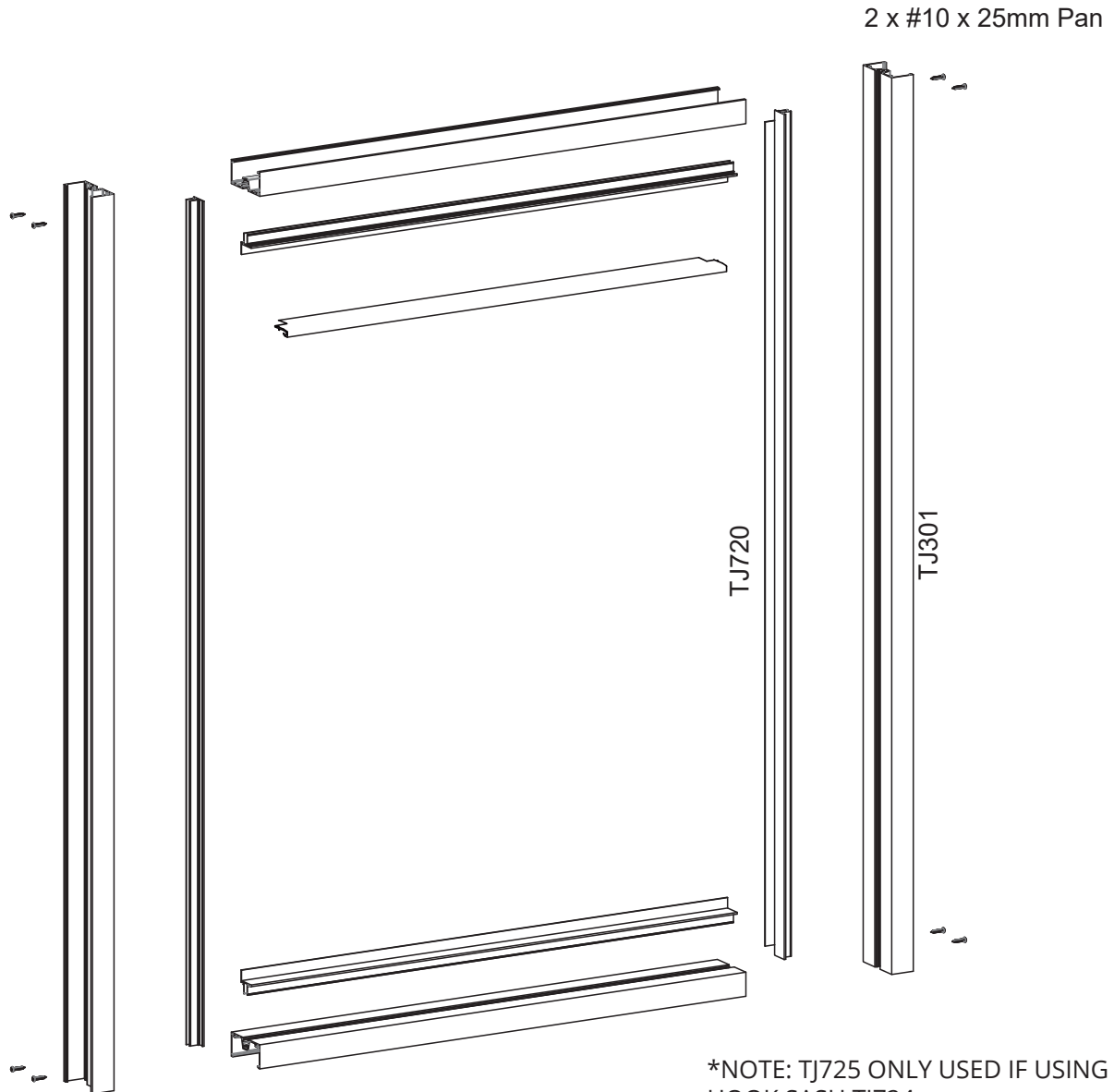

\*NOTE: TJ725 ONLY USED IF USING HOOK SASH TJ724

FOR ALL OTHER FRAME/STOP OPTIONS, SEE TABLE ON PAGE 23.

### Exploded Frame Assembly: Stays & Hook

All raw joints need to be sealed with small joint sealer or foam tab option.

Fabrication

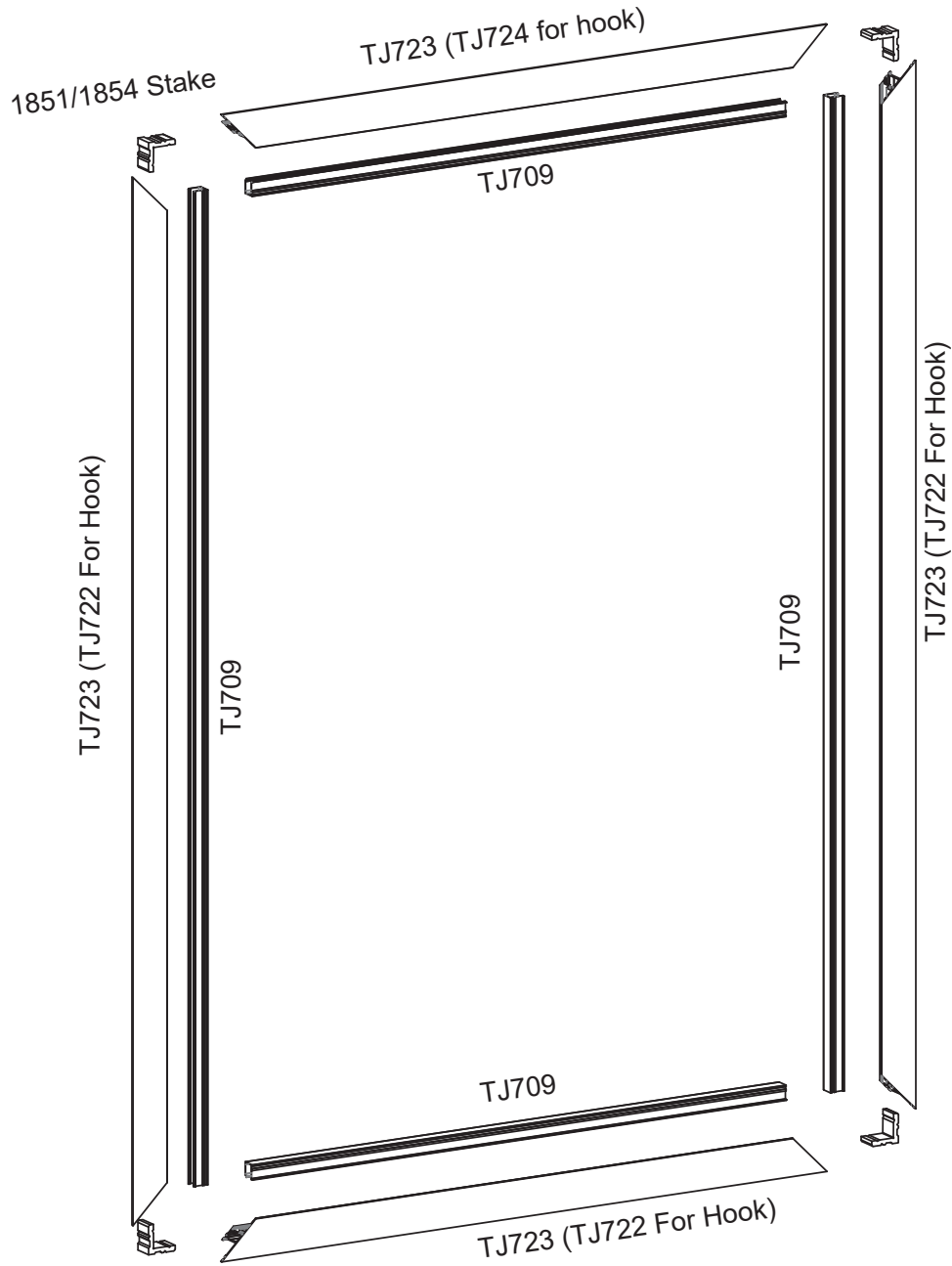

See also: Disclaimer and Copyright information on page 3

### 100mm Subhead Options

All raw joints need to be sealed with small joint sealer or foam tab option.

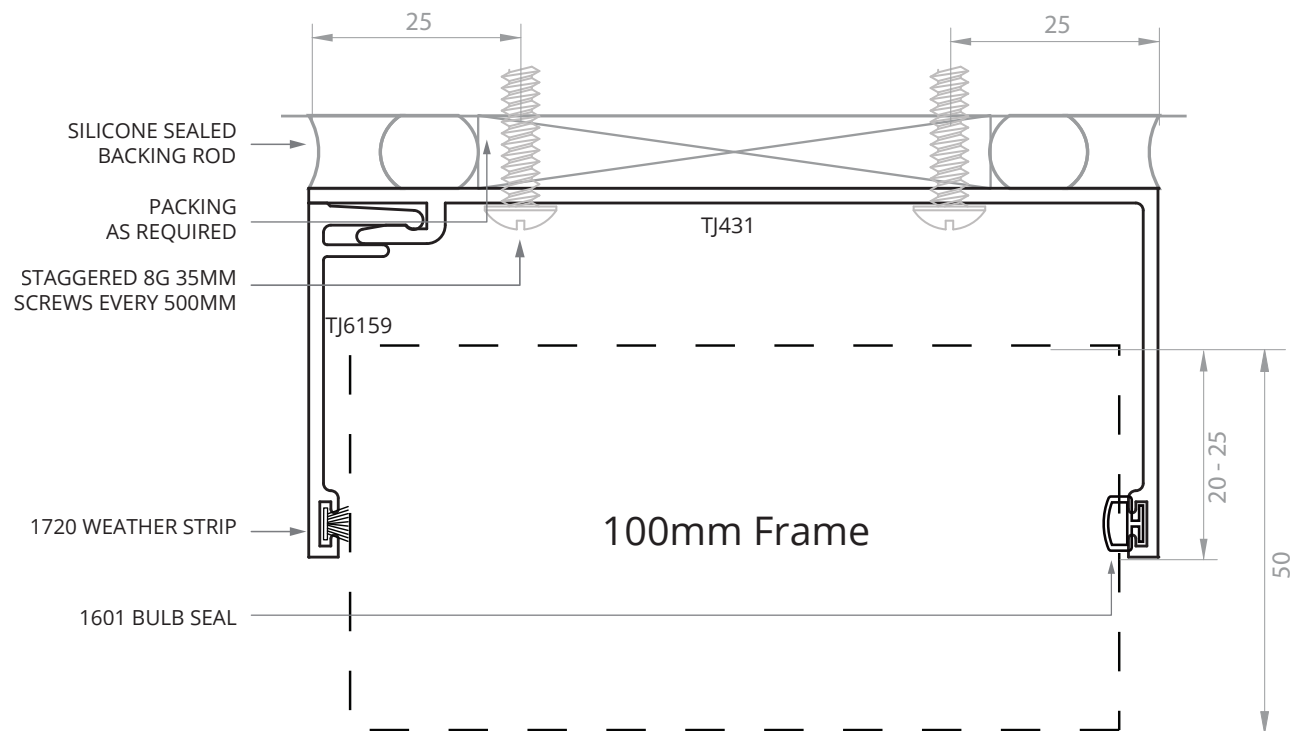
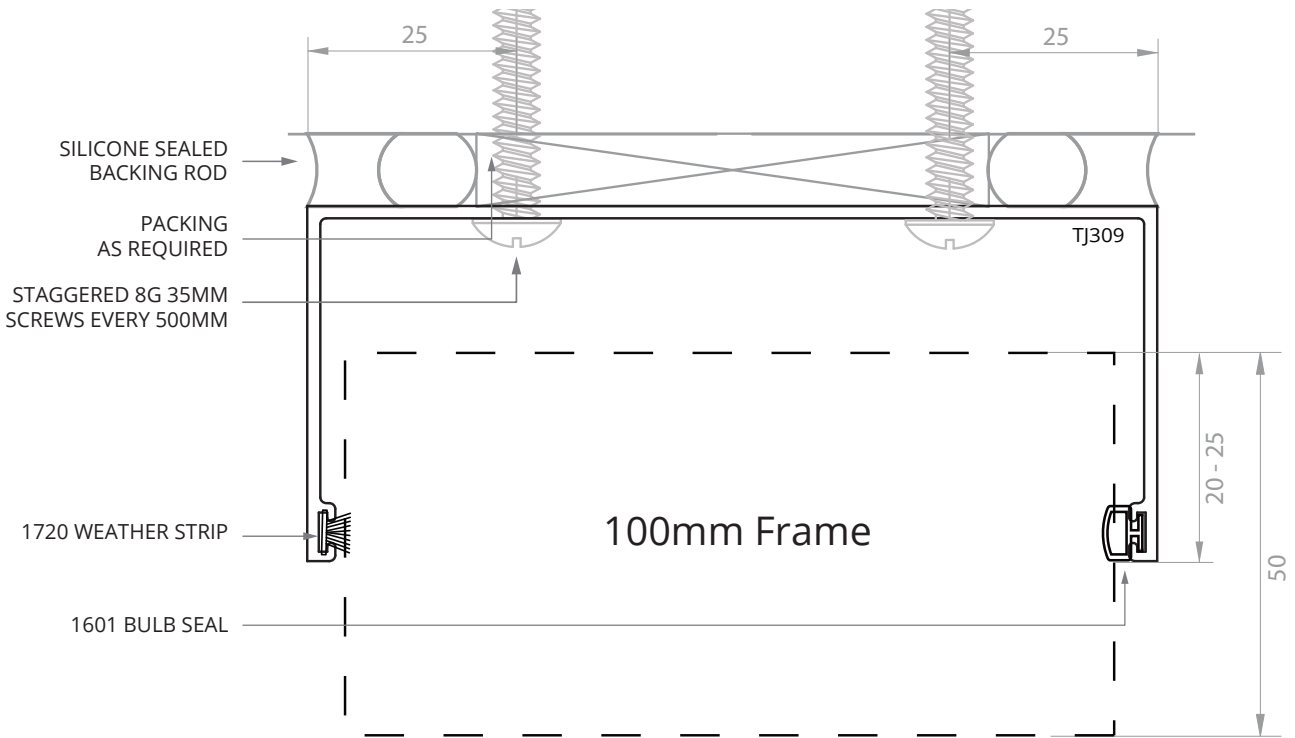

Fabrication

See also: Disclaimer and Copyright information on page 3

### 100mm SubJamb Options

All raw joints need to be sealed with small joint sealer or foam tab option.

Fabrication

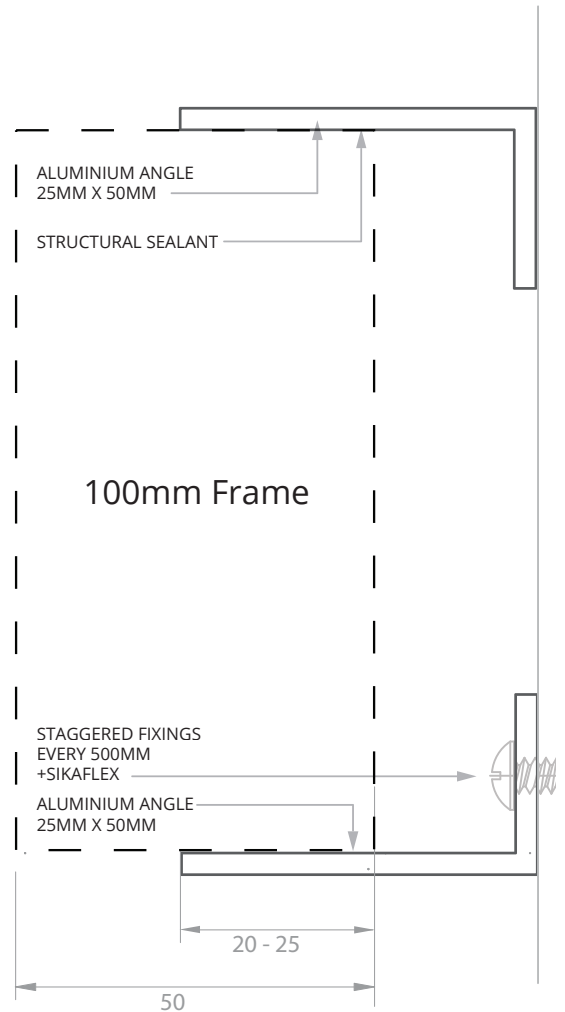
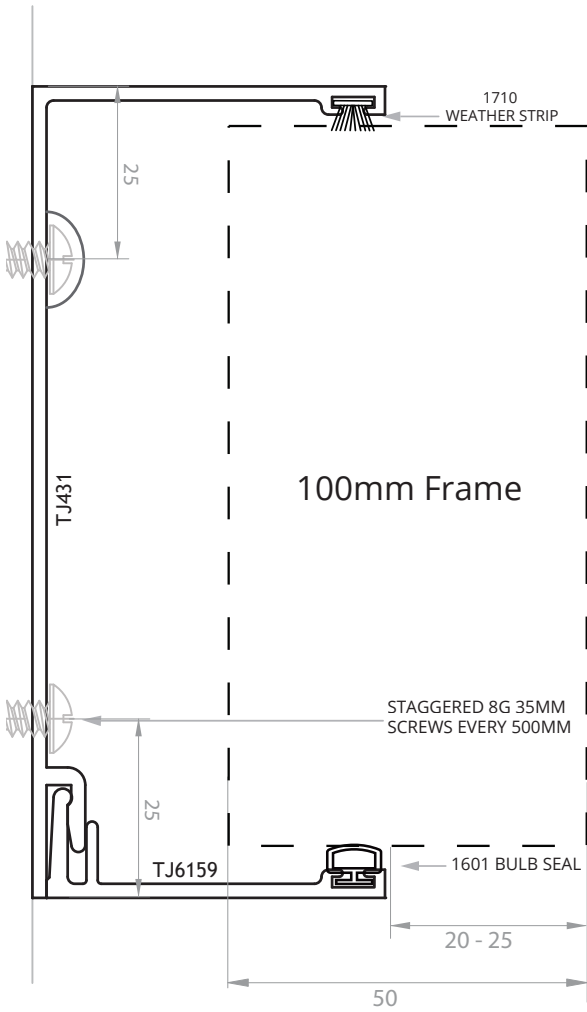

See also: Disclaimer and Copyright information on page 3

### 100mm Subframe Internal Bead

All raw joints need to be sealed with small joint sealer or foam tab option.

SQUARE CUT (INTERNAL BEAD)

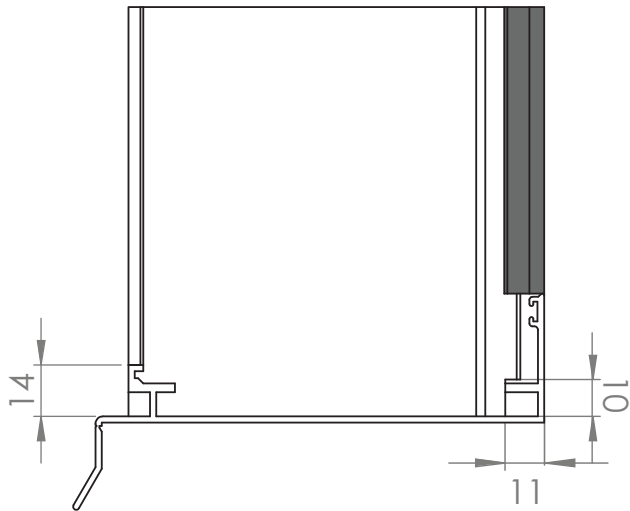

MACHINED (INTERNAL BEAD)

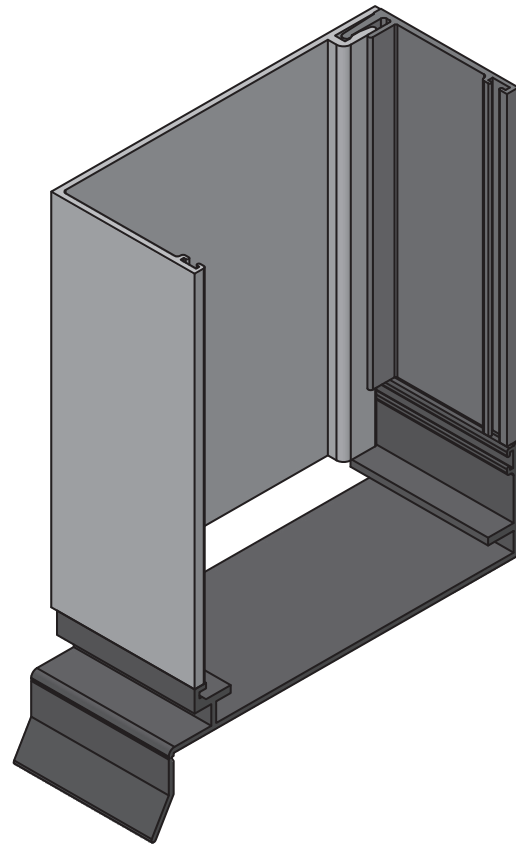
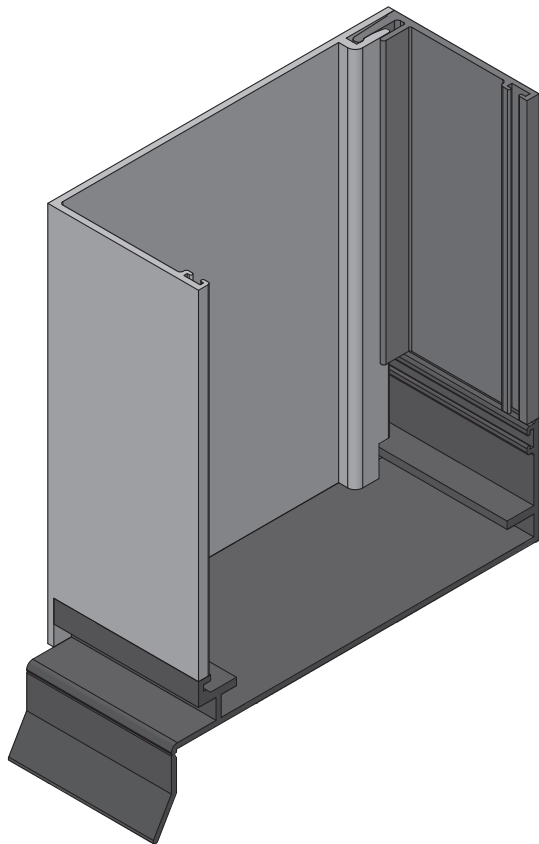
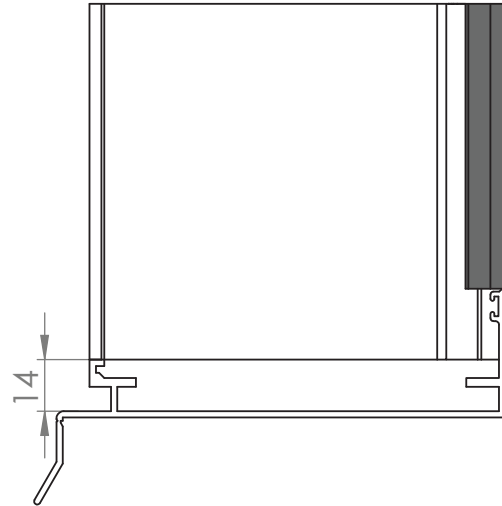

See also: Disclaimer and Copyright information on page 3

### 100mm Subframe External Bead

All raw joints need to be sealed with small joint sealer or foam tab option.

Fabrication

SQUARE CUT (EXTERNAL BEAD)

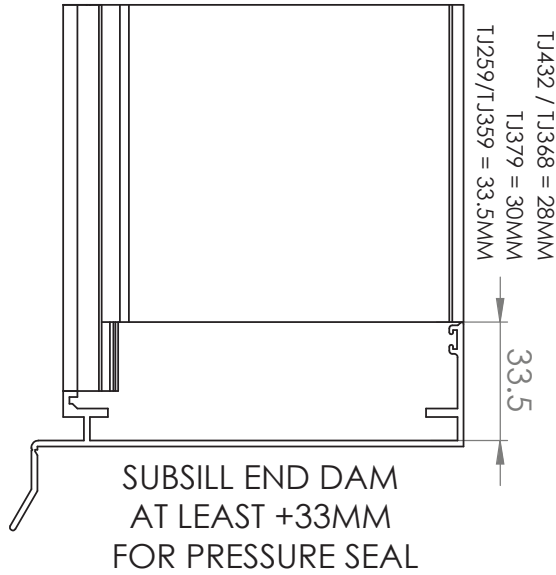

MACHINED (EXTERNAL BEAD)

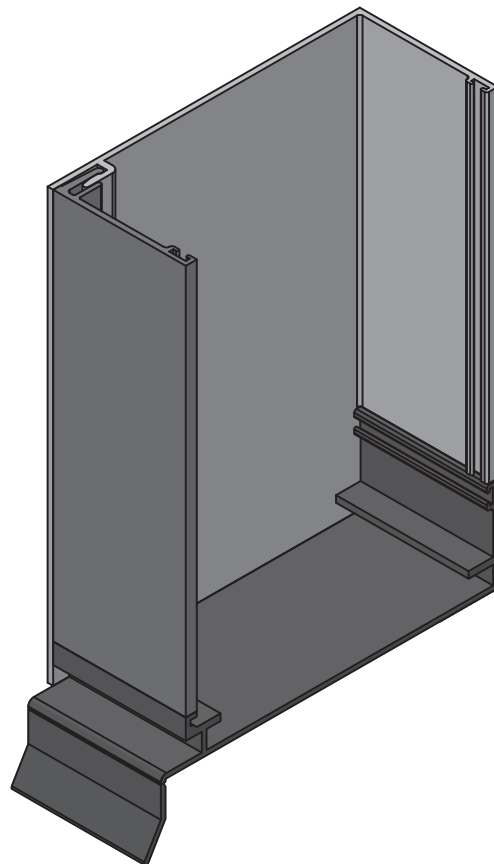
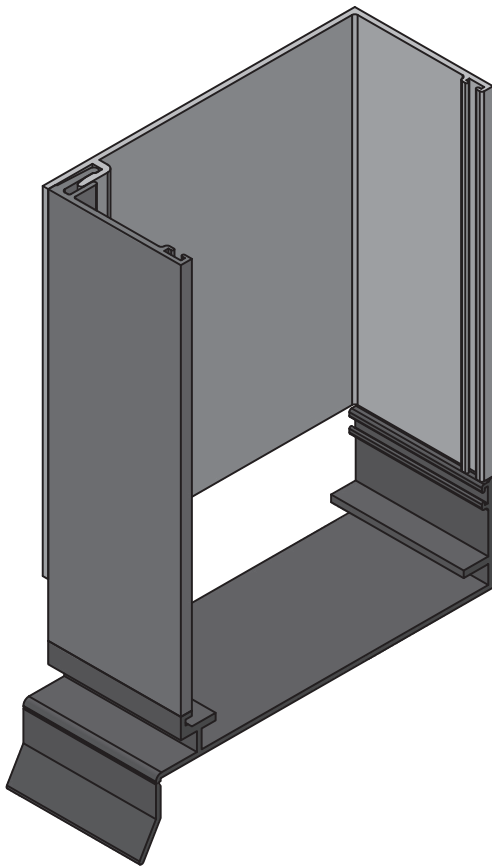
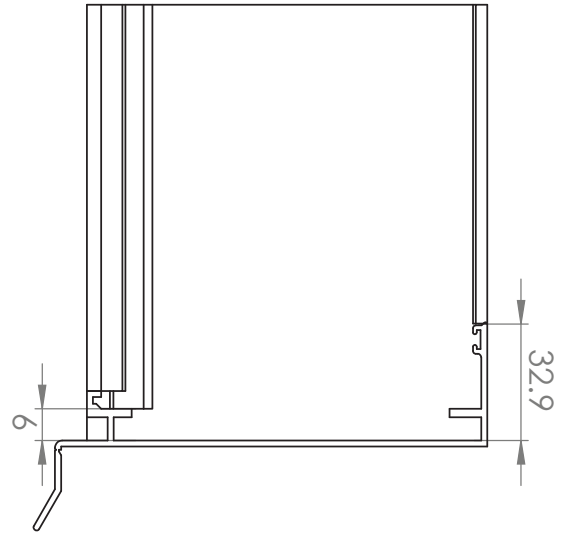

See also: Disclaimer and Copyright information on page 3

## Subsill End-Dam Installation

All raw joints need to be sealed with small joint sealer or foam tab option.

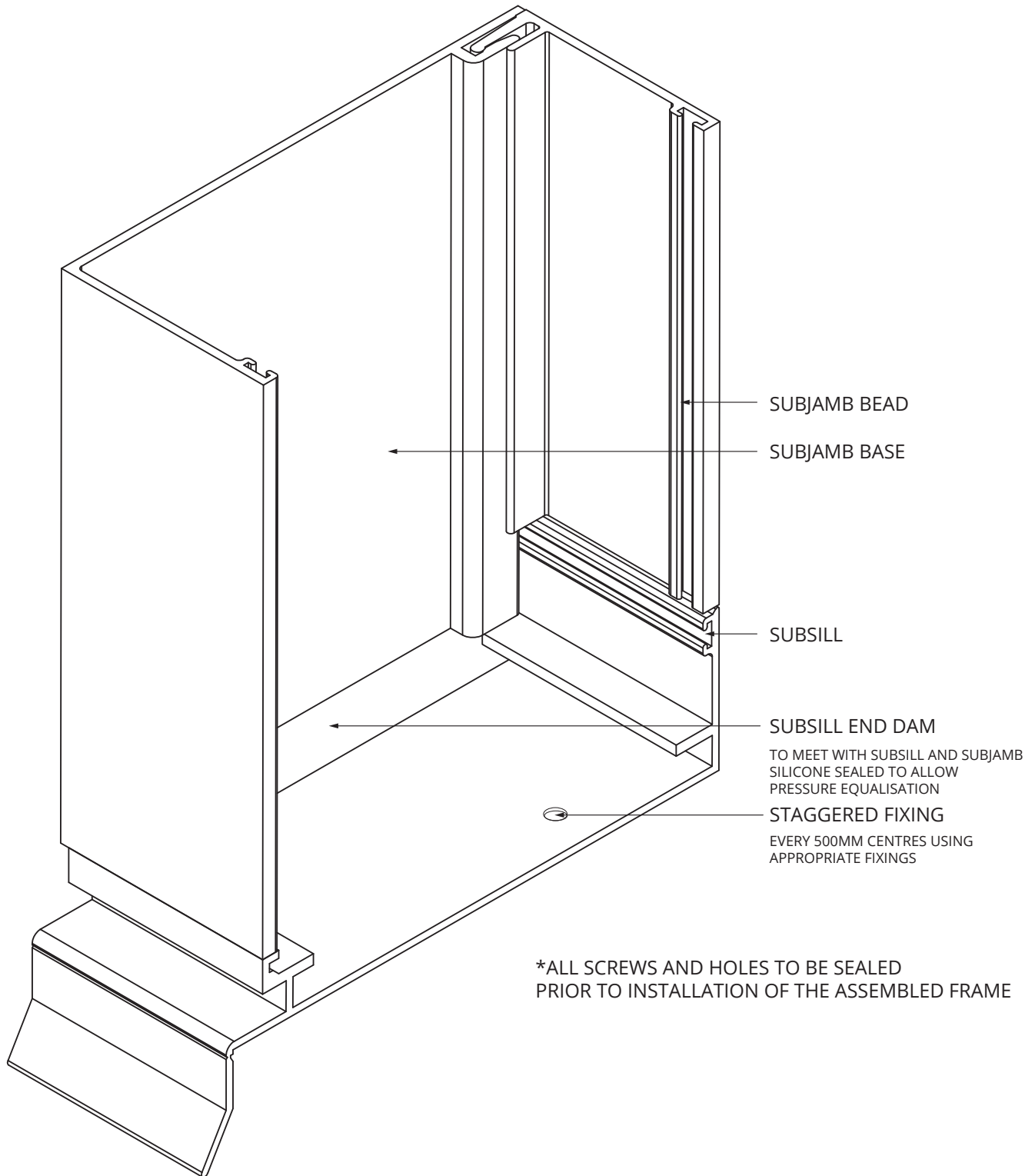

See also: Disclaimer and Copyright information on page 3

All raw joints need to be sealed with small joint sealer or foam tab option.

Fabrication

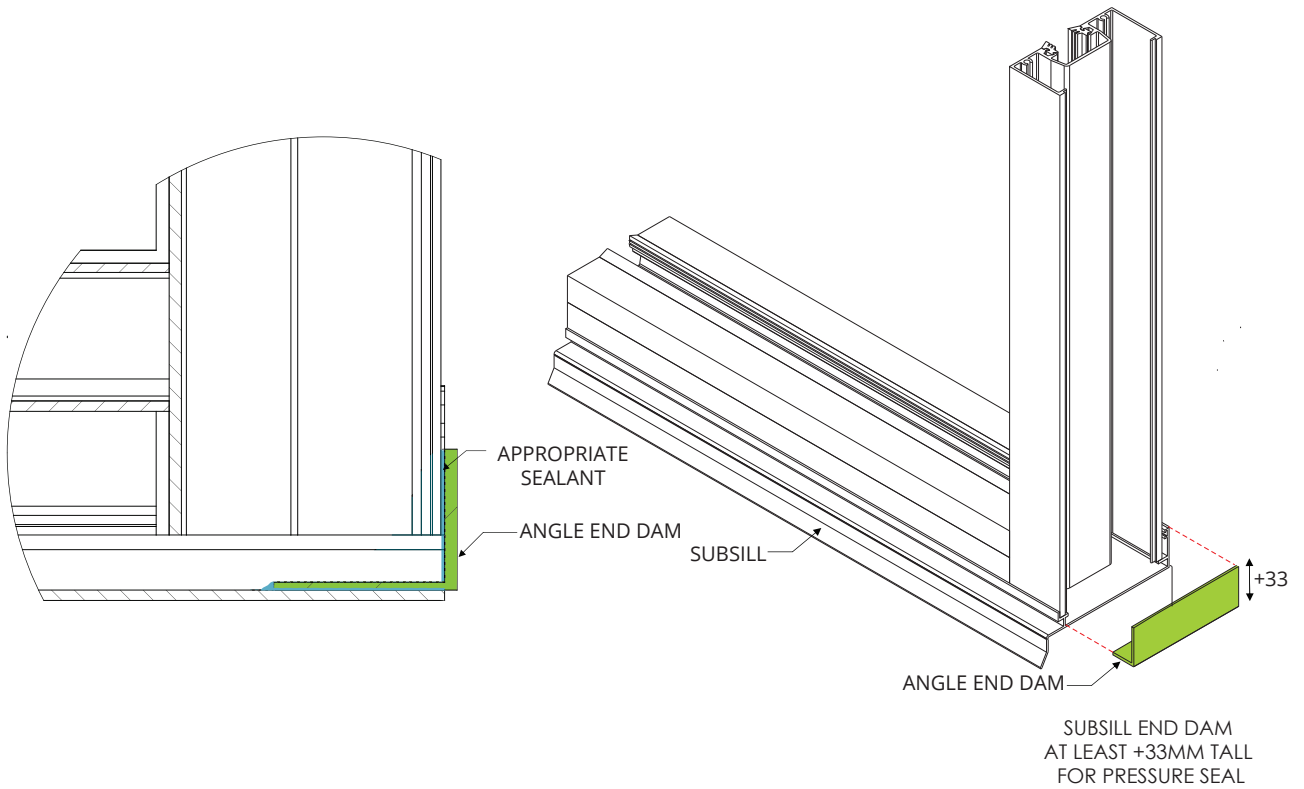
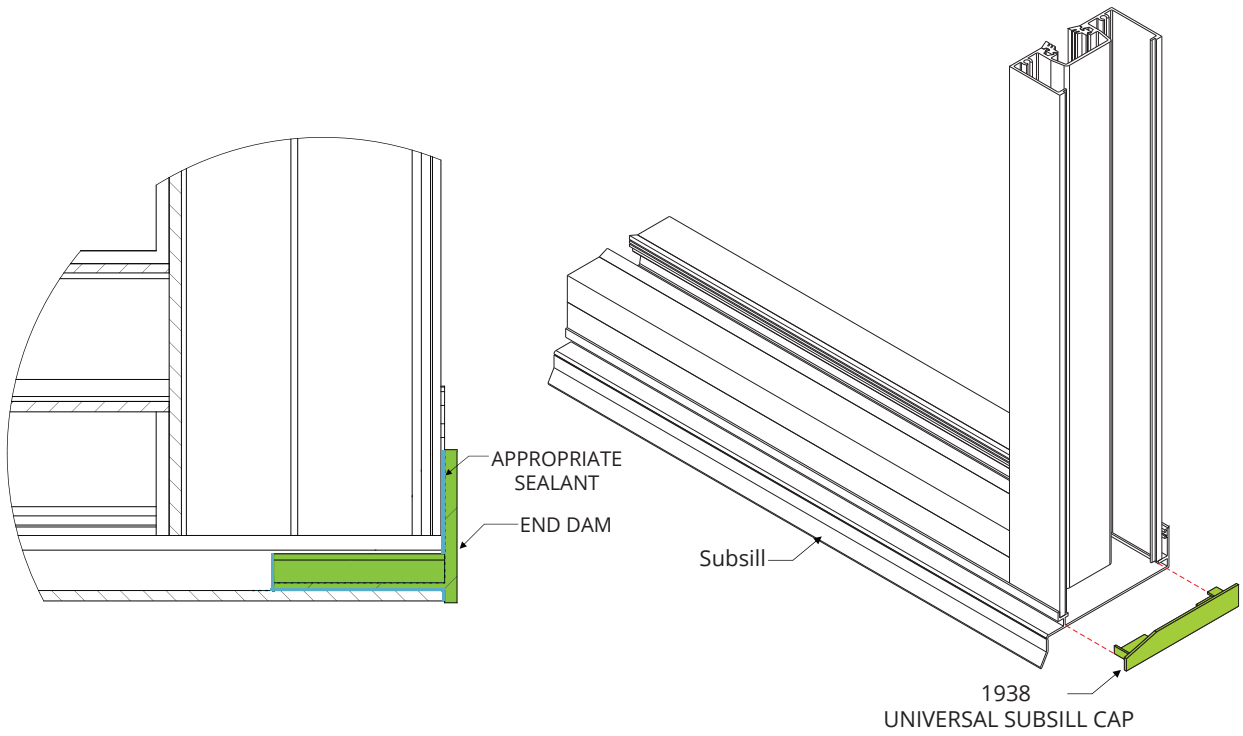

See also: Disclaimer and Copyright information on page 3

# 100mm Sump Sill

All raw joints need to be sealed with small joint sealer or foam tab option.

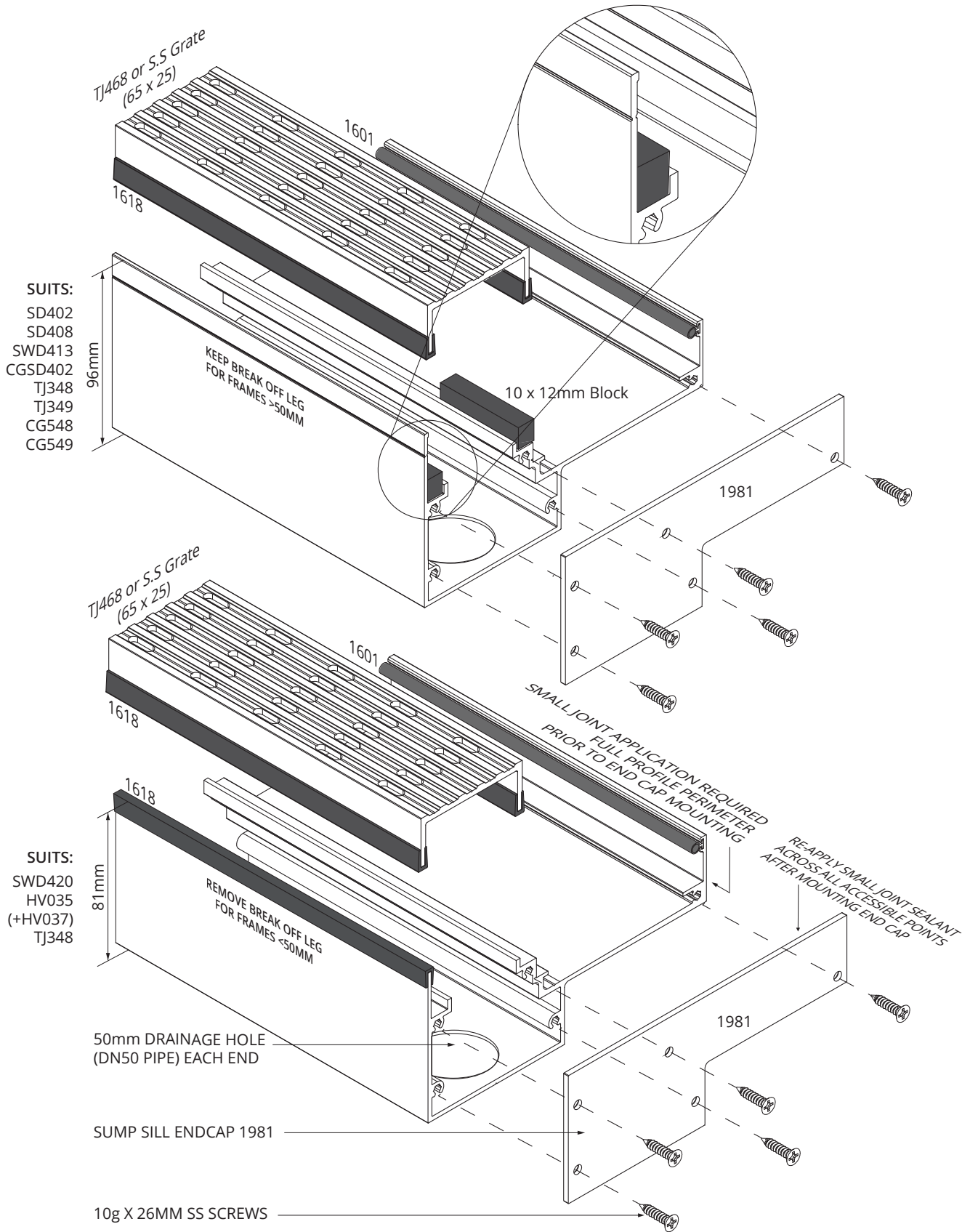

Fabrication

See also: Disclaimer and Copyright information on page 3

### TJ400 Slab Recess Details (1:1)

All raw joints need to be sealed with small joint sealer or foam tab option.

Fabrication

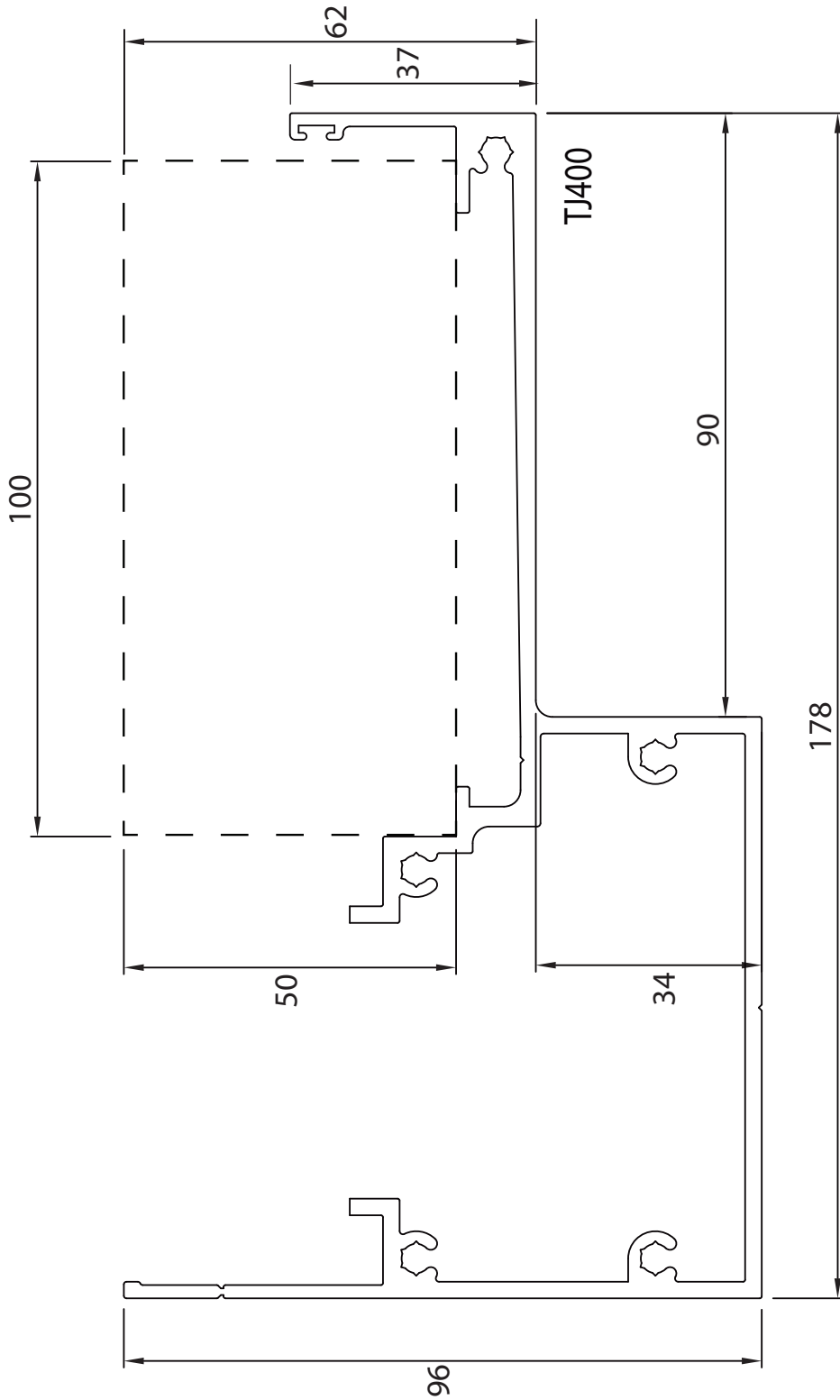

See also: Disclaimer and Copyright information on page 3

### 150mm Subhead Options

All raw joints need to be sealed with small joint sealer or foam tab option.

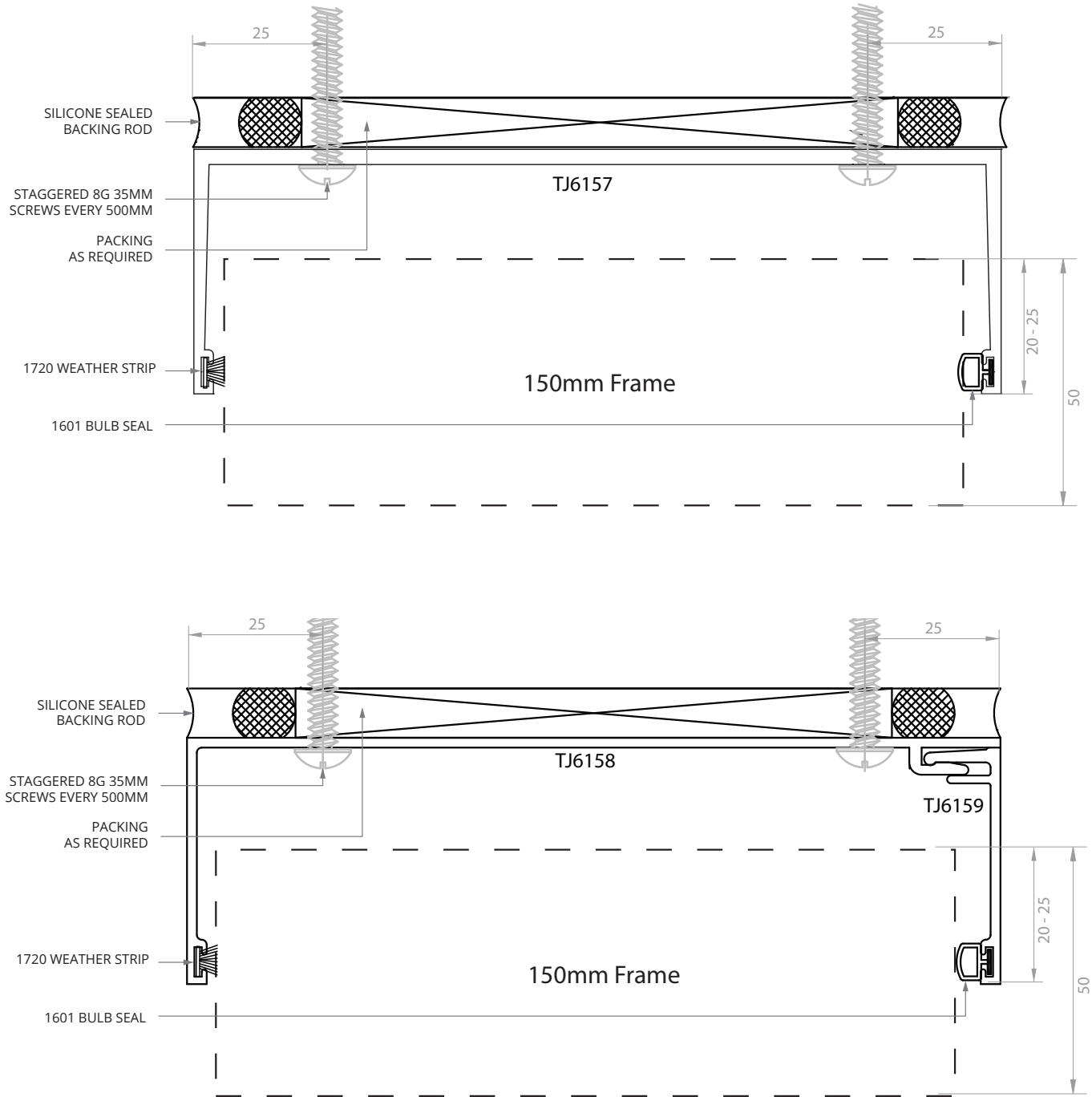

Fabrication

See also: Disclaimer and Copyright information on page 3

### 150mm SubJamb Options

All raw joints need to be sealed with small joint sealer or foam tab option.

Fabrication

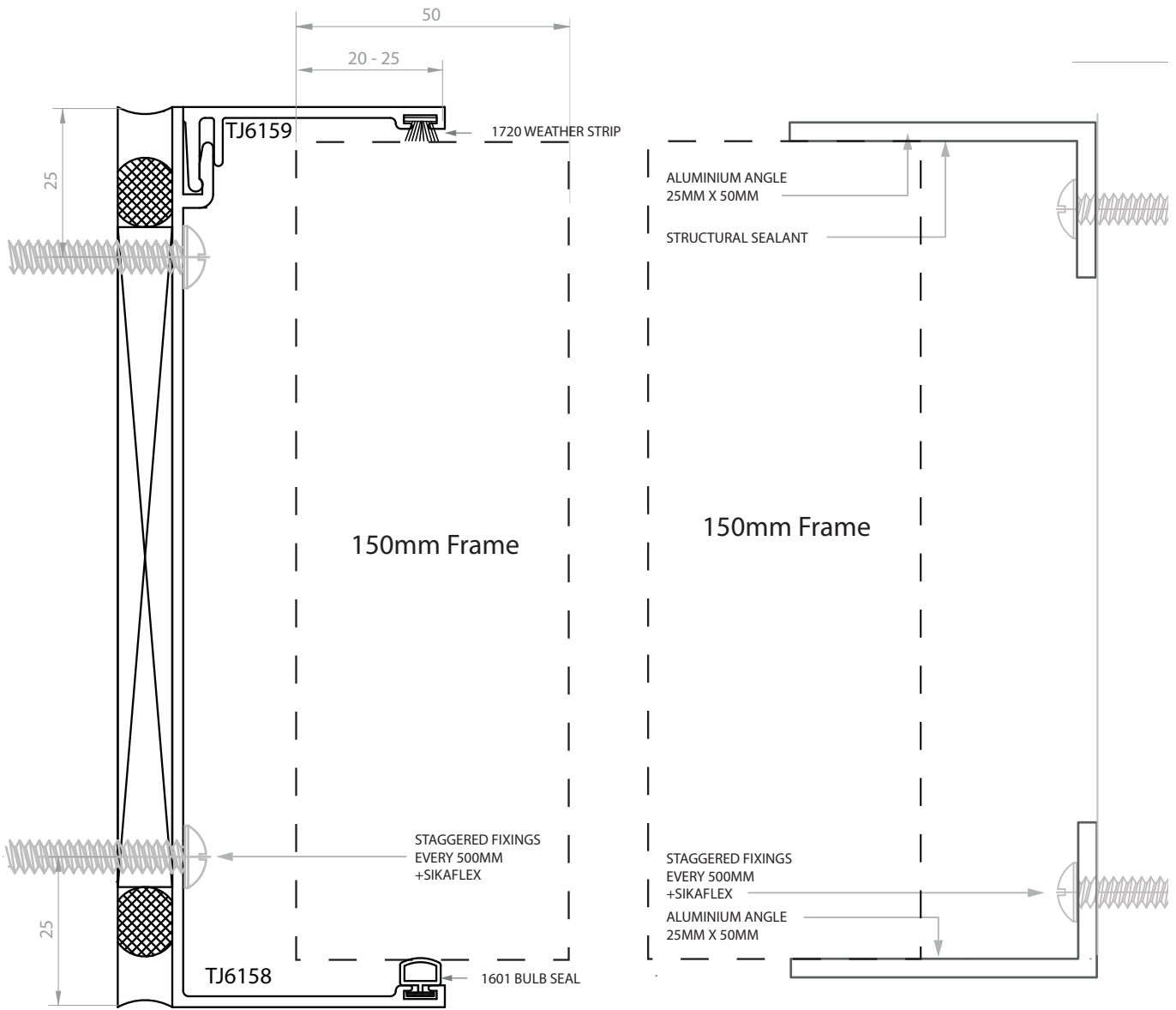

See also: Disclaimer and Copyright information on page 3

## 150mm Subframe Internal Bead

All raw joints need to be sealed with small joint sealer or foam tab option.

### MACHINED (INTERNAL BEAD)

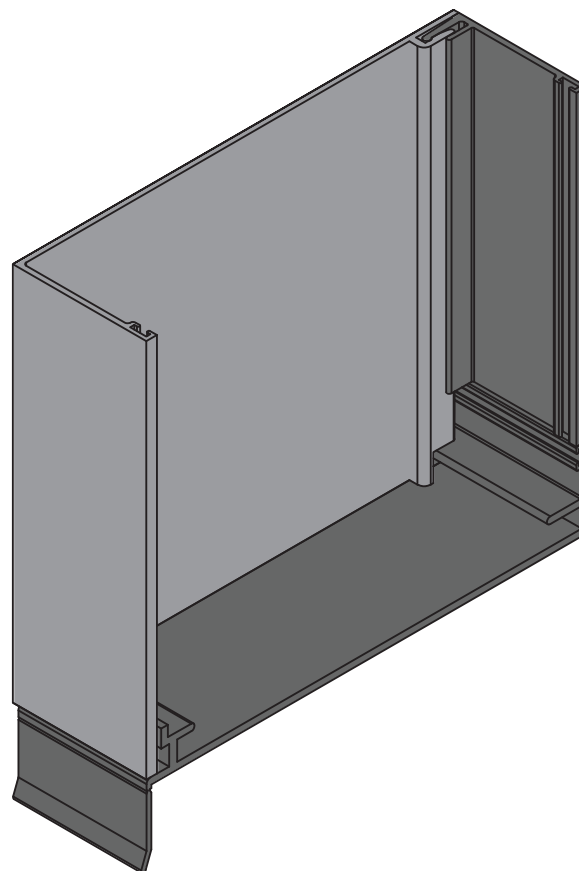
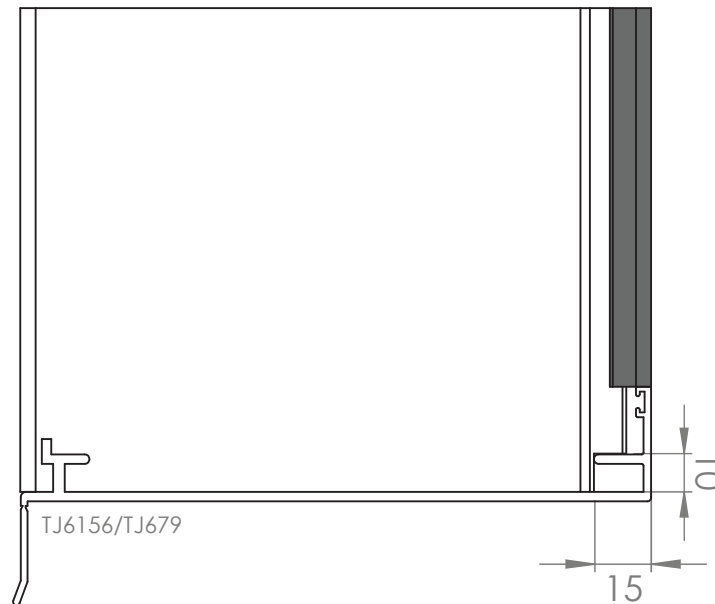

Fabrication

See also: Disclaimer and Copyright information on page 3

### 150mm Subframe External Bead

All raw joints need to be sealed with small joint sealer or foam tab option.

Fabrication

SQUARE CUT (EXTERNAL BEAD)

MACHINED (EXTERNAL BEAD)

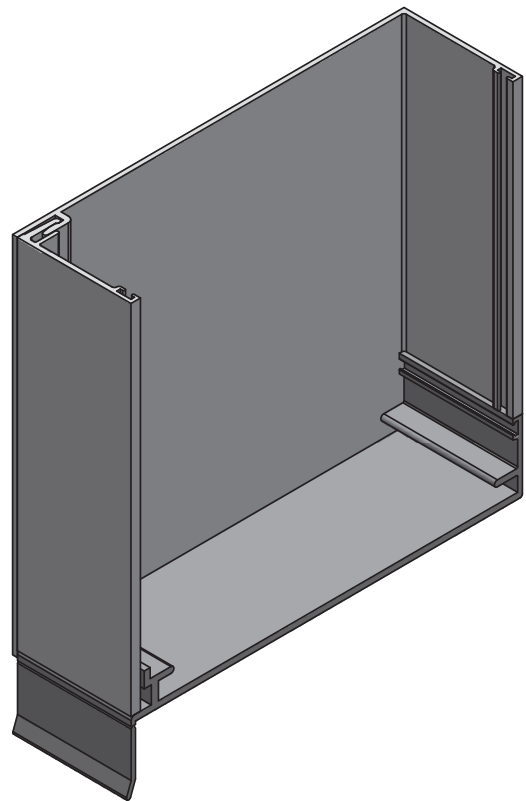
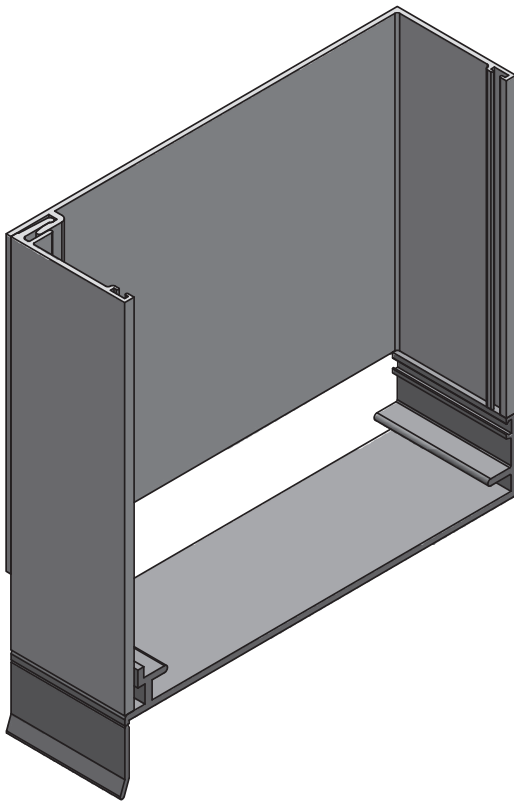
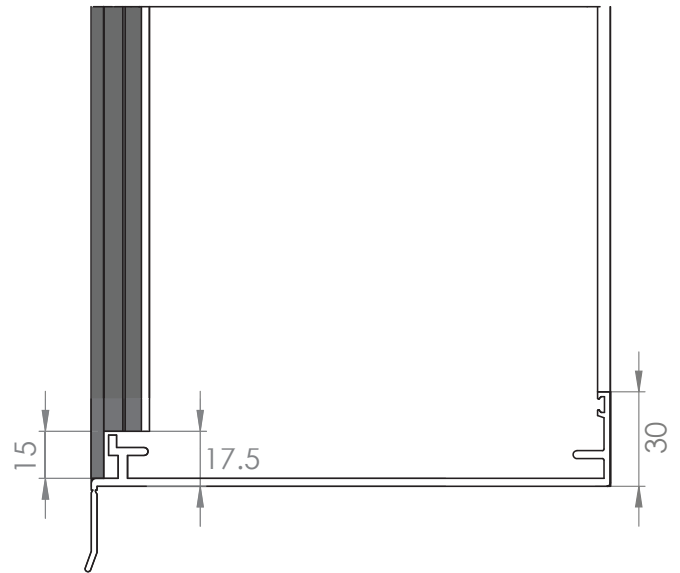
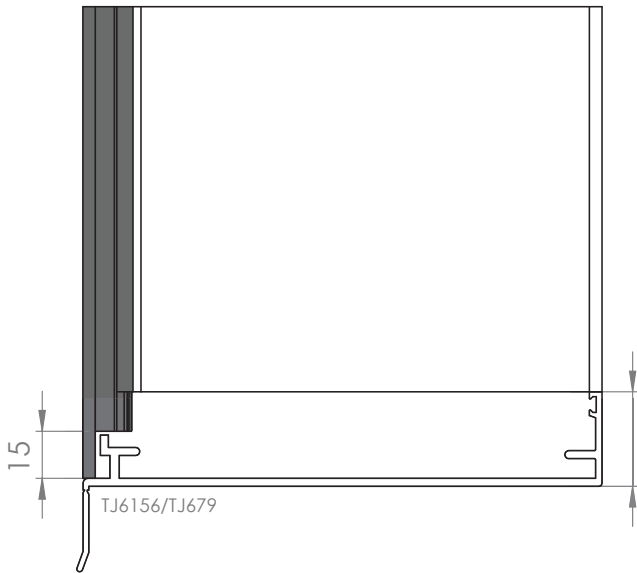

See also: Disclaimer and Copyright information on page 3

## Subsill End-Dam Installation

All raw joints need to be sealed with small joint sealer or foam tab option.

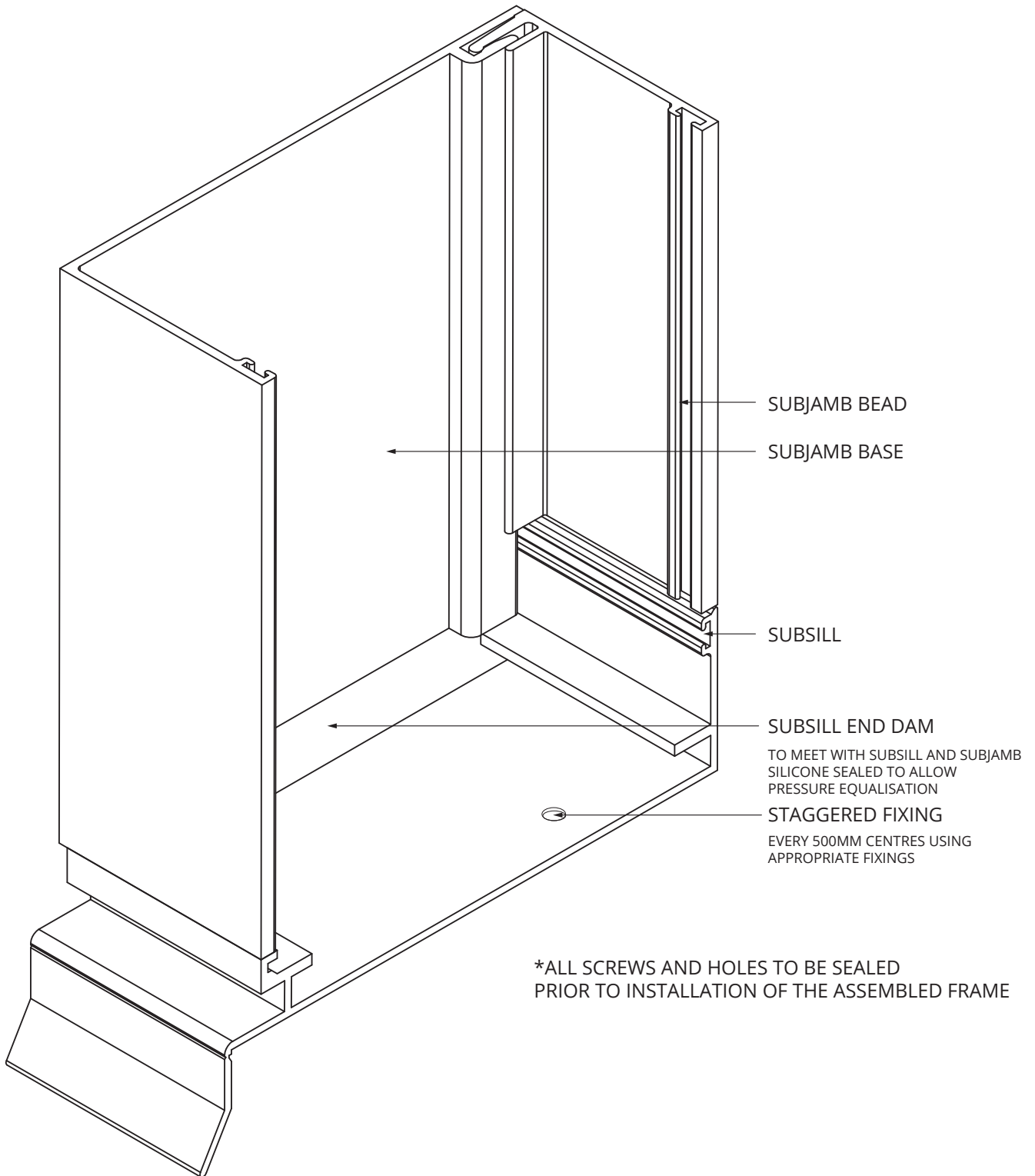

Fabrication

See also: Disclaimer and Copyright information on page 3

All raw joints need to be sealed with small joint sealer or foam tab option.

Fabrication

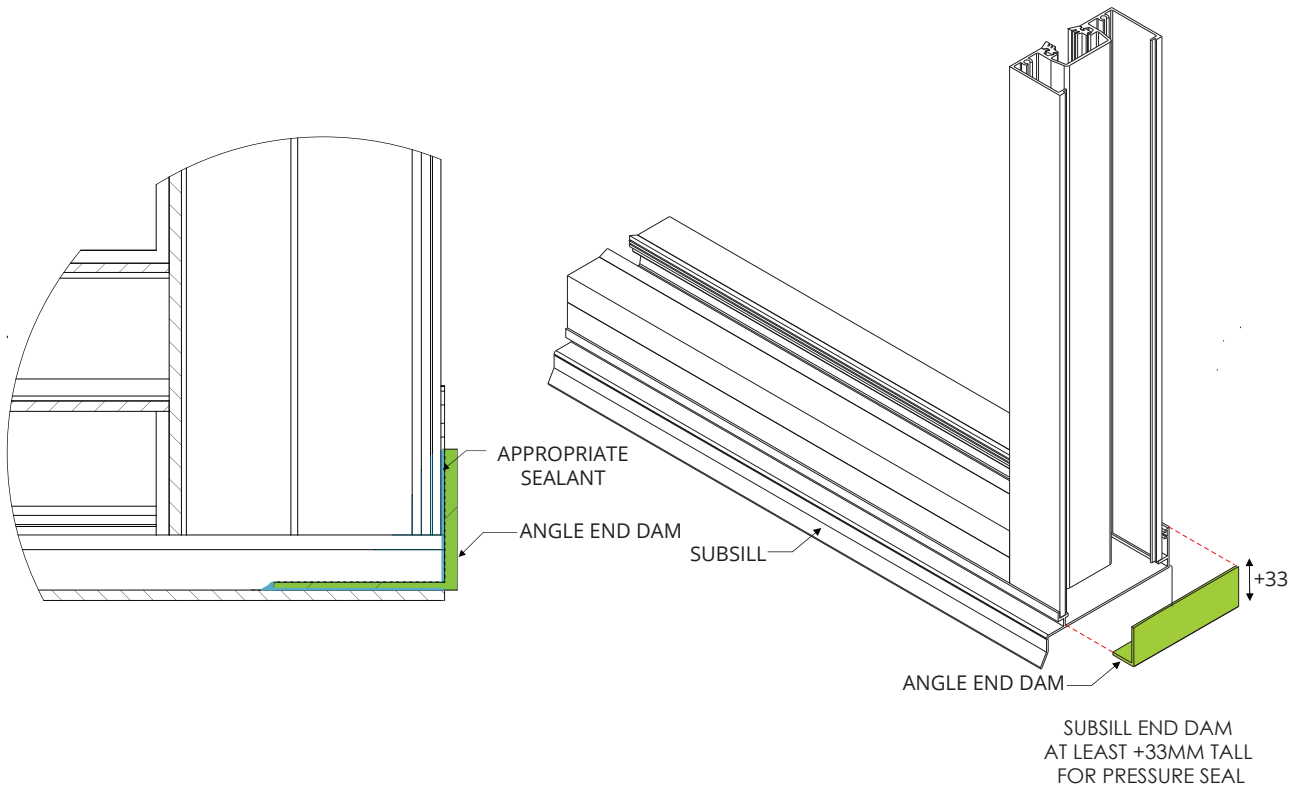
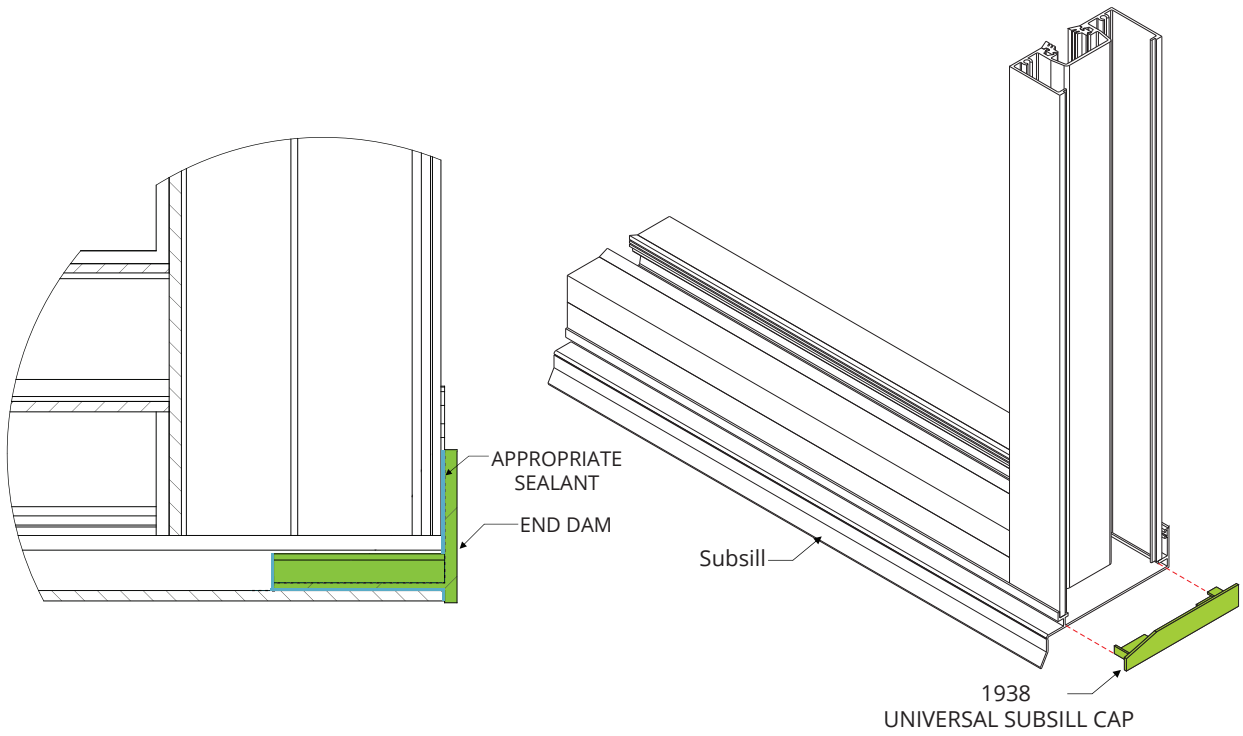

See also: Disclaimer and Copyright information on page 3

# 150mm Sump Sill

All raw joints need to be sealed with small joint sealer or foam tab option.

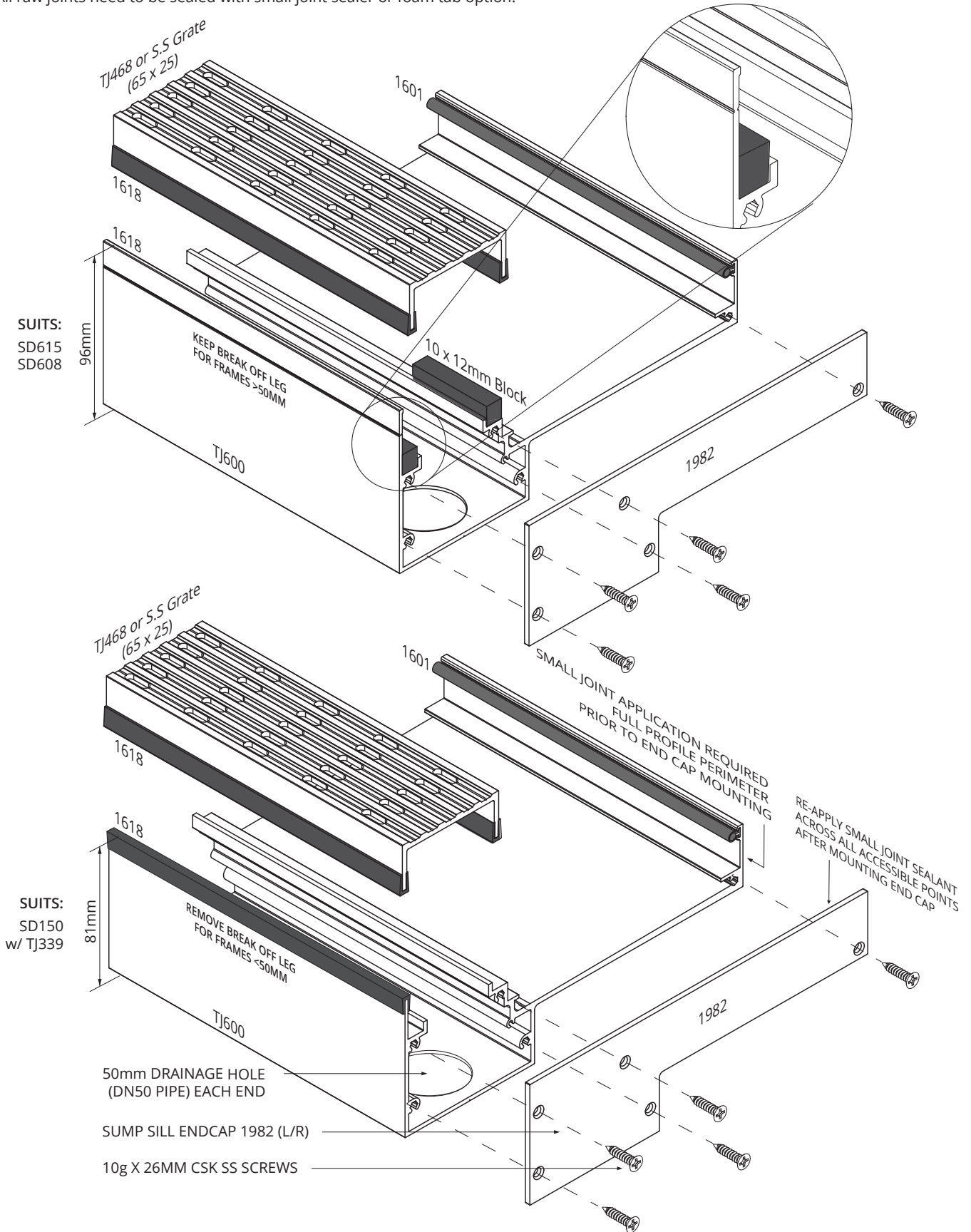

Fabrication

See also: Disclaimer and Copyright information on page 3

### TJ600 Slab Recess Details (1:1)

All raw joints need to be sealed with small joint sealer or foam tab option.

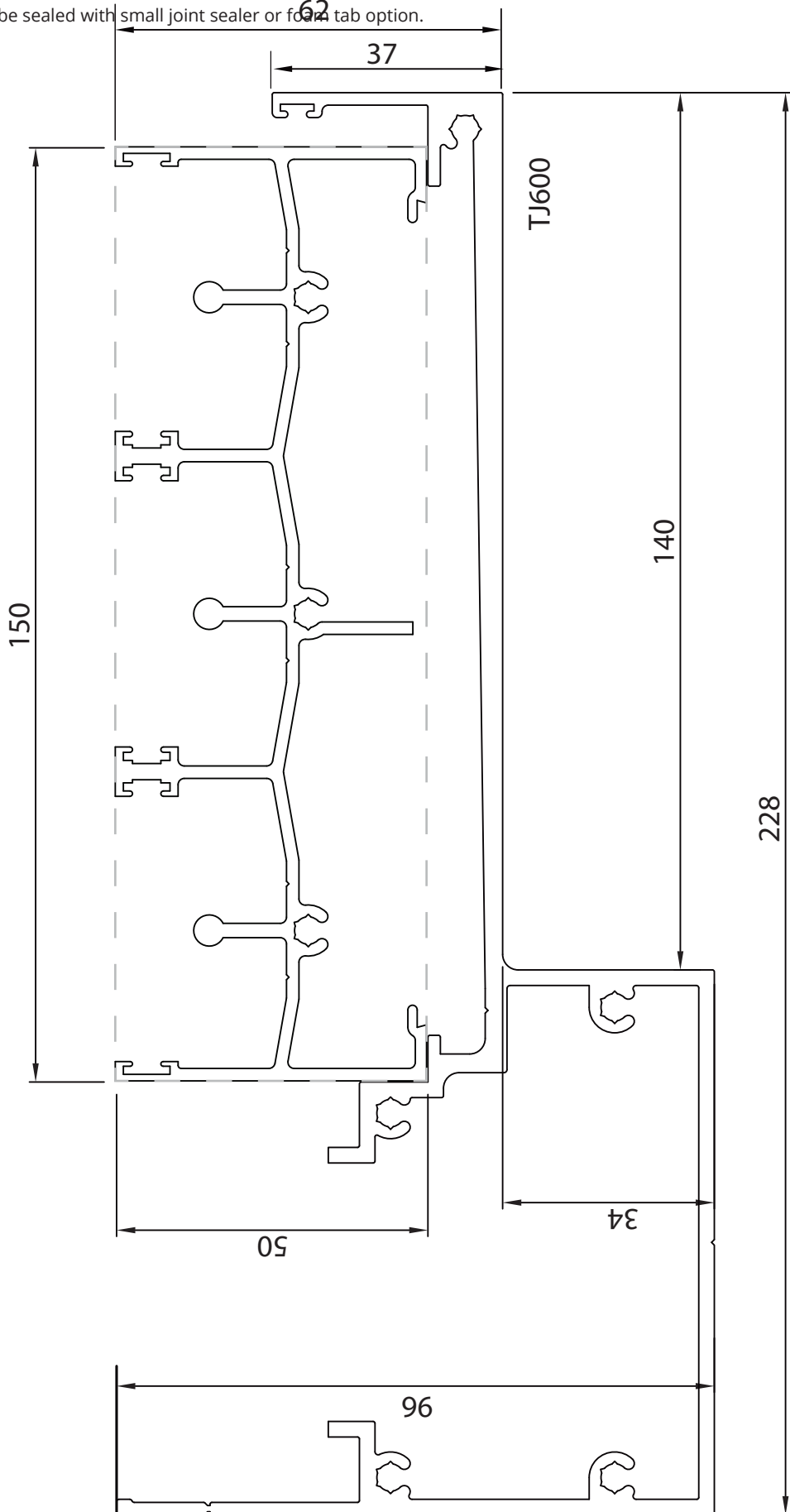

Fabrication

See also: Disclaimer and Copyright information on page 3

## Tooling

All raw joints need to be sealed with small joint sealer or foam tab option.

# CARE & MAINTENANCE

## KlassicView / CityView / ClimateGuard

### Tooling Operation Manual

The following guidelines should be observed to ensure safe and efficient use, longevity and quality production.

All users are responsible for the safe operation and maintenance of tools.

- \* Read the entire Manual before starting machinery. Machinery may cause serious injury if not correctly operated.
- \* Never leave machine unattended. Turn power off and wait until machine has come to a complete stop before leaving the machine unattended.
- \* Disconnect main power before servicing machine. Make sure all power switches are in the off position and air disconnected and make sure all moving parts have come to a complete stop.
- \* Keep machine well-guarded. Do not remove guards and ensure all guards are in place prior to operation.
- \* Electric pump will shut down to prevent further damage if there is not enough lubricant.

#### **General Maintenance:**

- \* Please keep tooling lubricated. We recommend using kerosene poured into a spray bottle. Lubricate all pins & blades before starting the machine. (PIC 1)
- \* We also recommend fortnightly cleaning and lubrication of the guide pins and bushes at the front and rear on both decks. (PIC 2)

*Note! Do not use silicon based lubricant under any circumstances as this will build up on the cutting edges of the tool and result in shorter operating life and poor quality results.*

#### **Operation:**

- \* Check machine over before operating. Check machine for damaged parts, loose bolts, loose connections, keys and wrenches left on the machine and any other conditions that may affect the machines operation. Repair and replace damaged parts.
  - \* Do not use extrusion that are not specified for this machine.
  - \* Do not use burred, heavy coated or bent extrusions or force extrusions into the tool.
- Note that manufacturing tolerance on aluminium can vary. Never hit or force extrusions into die guides.*
- \* While operating do not remove guards and always keep hands outside of the guards.
  - \* Empty swarf trays when required to prevent build up obstructing clearance of discarded aluminium.

Periodically, the die and punches will need sharpening. This must be carried out by experienced toolmaker.

## Tooling

All raw joints need to be sealed with small joint sealer or foam tab option.

### BDX-CV-CSG/H/AW CSG Frame / Hinged /Hook Awning

CSG301	100mm Standard Main Frame	TJ435	114mm Open Pocket Hinge Stile
CSG303	CSG Bead	TJ436	114mm Open Pocket Lock Stile
CSG303B	CSG Sloped Bead	TJ437	114mm Open Pocket Plain Stile
CSG304	Glazing Adaptor	TJ440	73mm Open Pocket Lock Stile
CSG320	Standard Duty Self Mating Mullion	TJ441	73mm Open Pocket Hinge Stile
CSG333	Heavy Duty Self Mating Mullion	TJ443	73mm Open Pocket Sliding Stile
CSG360	100mm Centre Glazed Slim Frame	TJ444	73mm Open Pocket Plain Stile
CSG362	CSG Transom/Sill	TJ450	73mm Open Pocket Meeting Stile
CSG390	100mm Light Duty Frame	TJ451	114mm Open Pocket Lock Stile
CSG601	150mm Standard Main Frame	TJ452	114mm Open Pocket Hinge Stile
CSG603	CSG Bead	TJ453	114mm Open Pocket Sliding Stile
CSG604	Glazing Adaptor	TJ725	114mm Open Pocket Plain Stile
CSG633	Self Mating Mullion	TJ737	Flyscreen Adaptor/Winder Support
CDG4301	100mm Centre Double Glazed Main Frame	TJ742	Awning Stile/Rail
CDG4303	Sill Bead	TJ747	Hook Awning Sash Rail
CDG4303M	Sill Sloped bead	TJ749	Hook Awning Sash Stop
CDG4304	Glazing Adaptor		
CDG4310	Male Split Mullion		
CDG4311	Female Split Mullion		
CDG4312	H/D Male Split Mullion		
CDG4313	H/D Female Split Mullion		
CDG4314	Male Light Split Mullion		
CDG4315	Female Light Split Mullion		
CDG4390	Transom/Sill		
CDG6501	150mm Centre DG Main Frame		
CDG6503	Sill Bead		
CDG6504	Glazing Adaptor		
CDG6510	Male Split Mullion		
CDG6511	Female Split Mullion		
CDG6512	H/D Male Split Mullion		
CDG6513	H/D Female Split Mullion		
HV271	Door Stile		
HV272	Hinge Stile		
HV273	Large Rail		
HV275	Large DG Rail		
HV277	Small DG Rail		
HV289	Small Rail		
HV291	DG Stile		
HV322	Sliding Door stile		
TJ154	114mm Hinge Stile		
TJ155	114mm Lock Stile		
TJ158	114mm Pivot Stile		
TJ159	114mm Sliding Stile		
TJ311	Hinge Stile		
TJ312	Lock Stile		
TJ313	Door Top Rail		
TJ315	Door Bottom Rail		
TJ322	Sliding Door Stile		
TJ327	Meeting Stile		
TJ416	73mm Open Pocket Sliding Stile		
TJ417	73mm Open Pocket Hinge Stile		
TJ418	73mm Open Pocket Lock Stile		
TJ419	DG Top Rail		
TJ420	DG Bottom Rail		
TJ428	114mm Open Pocket Sliding Stile		

#### [BDX-CV-CSG/H/AW tool set information](#)

Weight	900kg
Dimensions	1420 x 1140 x 800mm (H x W x D)
Outrigger	Yes



See also: Disclaimer and Copyright information on page 3

## Tooling

All raw joints need to be sealed with small joint sealer or foam tab option.

# CARE & MAINTENANCE

### **Exchange or replace die:**

\* This is only to be carried out by suitability qualified persons:

1. Switch off the machine and isolate power point. Removing front covers and swarf trays.
2. Remove top and bottom screws from the die. Carefully take out the old die block.
3. Reconnect the power and switch on the machine. Turn to INCHING MODE, press foot valve to ensure the machine desk is on lowest level.
4. Placing the new block and pins units inside and fixed back into their original positions, then release the inching mode back to operation mode.

### **Ordering procedure for Replacement or spare parts:**

\* Please provide following details to your sales representative

- Machine serial number:
- Port (DIE) location:
- List of extrusion involved:
- Take photo of the issues:

*(PIC 1) Lubricate all dark grey areas fortnightly with kerosene*

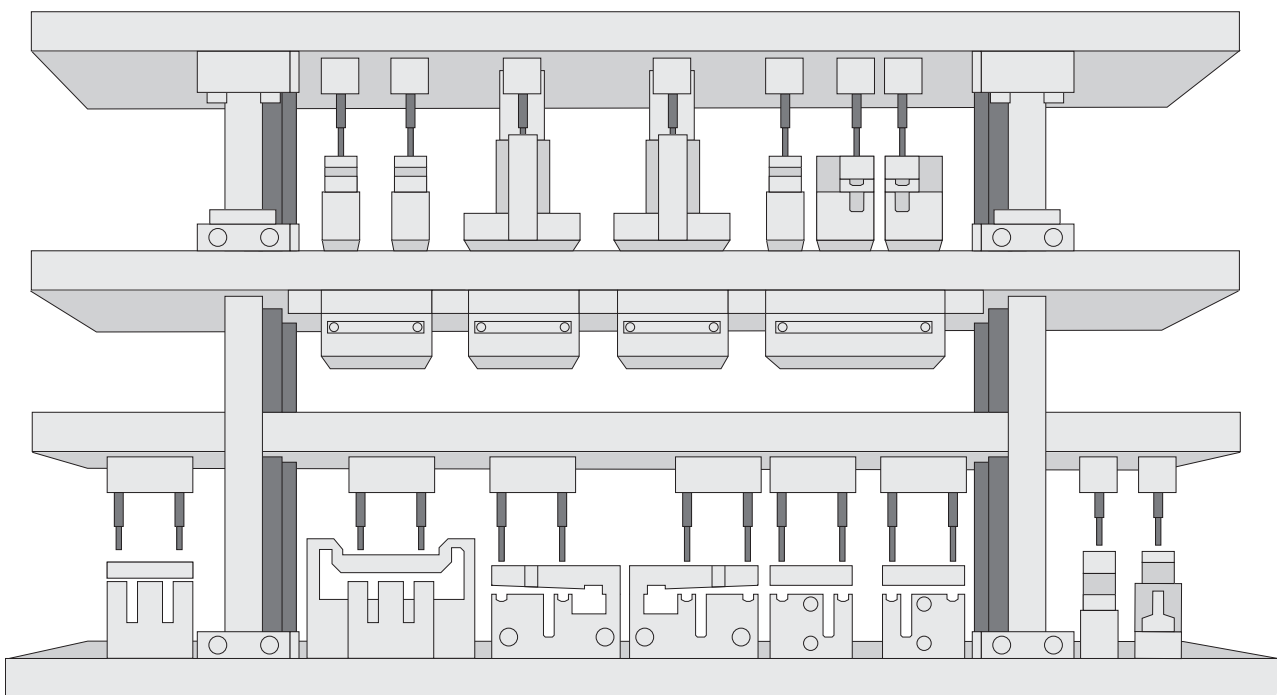

See also: Disclaimer and Copyright information on page 3

## Maintenance & Warranty



## Darley Aluminium

are long standing members of various industry associations including the Australian Glass & Window Association (AGWA) and the Window Energy Rating Scheme (WERS) and as such we conform to an Industry Code of Conduct designed to protect consumers.

## Manufacturing Standards;

All aluminium extrusions supplied to by Darley Aluminium have been supplied in accordance with Australian Standard AS1866 - 'Aluminium and Aluminium alloy: Extruded rod, bar, solid and hollow shapes'. All Anodised and Painted Extrusions are as per AS1231 Aluminium and Aluminium Alloys - 'Anodic Oxidation Coatings' and AS3715 - 'Metal Finishing-Thermoset Powder Coatings for Architectural Applications of Aluminium and Aluminium Alloys'.

## Product Testing and Compliance;

Darley Aluminium products are tested in NATA accredited independent laboratories to ensure they meet the relevant Australian Standards. Energy ratings can also be found on the Window Energy Rating Scheme (WERS) website:

<https://agwa.imiscloud.com/WERS/>

## Maintenance & Warranty

### Care & Maintenance

- A gentle wash with a soft non-abrasive brush or cloth using a mild detergent followed by a fresh water rinse will maintain the long term performance of the powder coat or anodised finish.
- If paint splashes, sealants or other residue need to be removed, then methylated spirits or white spirits can be applied with a soft cloth and gentle wiping only.
- In rural or normal urban environments, cleaning should occur at least every 12 months.
- In areas of pollution, industrial or coastal areas back one kilometre from the water, cleaning should occur at least every 3 months.
- In hazardous locations such as beachfronts, severe marine environments or areas of high industrial pollution, the frequency of cleaning should be increased to monthly.
- Special maintenance may be required in some extended warranty applications.

#### Tracks:

Keep tracks free from obstruction and excessive dirt or water.

#### Guides and Spindles:

To be greased with good quality automotive grease every 6 months.

#### Rollers:

As per manufacturer's instructions.

#### Hinges, Hangers & Flush Bolts:

Visible surfaces should be cleaned using a damp cloth and mild detergent, then wiped dry. Apply a light application of non-corrosive preventative lubricant to all surfaces and internals, using a dry cloth to remove excess. Repeat at intervals no greater than 3 months.

#### Seals and PVC Product:

An occasional wipe with a damp cloth or a wash with warm soapy water is all that is required.

#### Glass:

Simply wipe over the surface with a few drops of methylated spirits on a damp cloth, then polish the surface with a dry, lint-free, non-abrasive cloth.





### **SYDNEY HEAD OFFICE**

8 Tyrone Place, Erskine Park NSW 2759  
Tel: (02) 8887 2888  
Fax: (02) 9834 3244  
Email: sales@darleyaluminium.com.au

### **MELBOURNE**

10 Bridge Road, Keysborough VIC 3173  
Tel: (03) 9238 3888  
Fax: (03) 9768 7288  
Email: salesvic@darleyaluminium.com.au

### **BRISBANE**

29 Access Avenue, Yatala QLD 4207  
Tel: (07) 3287 1888  
Fax: (07) 3287 2088  
Email: salesqld@darleyaluminium.com.au

### **PERTH**

36 Armstrong Road, Hope Valley WA 6165  
Tel: (08) 9437 2999  
Fax: (08) 9437 1024  
Email: saleswa@darleyaluminium.com.au

[darleyaluminium.com.au](http://darleyaluminium.com.au)



AUSTRALIAN  
**GLASS &  
WINDOW**  
ASSOCIATION  
MEMBER